



HMI connection manual

WUXI XINJE ELECTRIC CO., LTD.

Data No. : HC 03 20220108 1.0

CATALOG

1 DESCRIPTION	1
1.1 Serial port of HMI	1
1.1.1 Download port	2
1.1.2 PLC port	4
1.1.3 Expand port	4
1.1.4 Ethernet port	6
1.2 Communication precautions	8
1.2.1 Selection of communication driver (protocol).....	8
1.2.2 Communication parameter description.....	8
2 THE CONNECTION OF PLC AND HMI	9
2.1 XINJE FC series PLC.....	9
2.1.1 Device type.....	9
2.1.2 Parameters	9
2.1.3 Cable making.....	9
2.1.4 Device address.....	10
2.2 XINJE XC series PLC	11
2.2.1 Device type.....	11
2.2.2 Parameters	11
2.2.3 Cable making.....	12
2.2.4 Device address.....	13
2.3 XINJE XD/XL/XG series PLC.....	14
2.3.1 Device type.....	14
2.3.2 Parameters	14
2.3.3 Cable making.....	15
2.3.4 Device address.....	16
2.4 XINJE X-NET communication	18
2.4.1 Device type.....	18
2.4.2 HMI setting.....	18
2.4.3 XD series PLC setting (PLC hardware V3.2.2 and up)	23
2.4.4 Cable making.....	26
2.4.5 Device address.....	28
2.5 Xinje V5 series inverter	30
2.5.1 Device type.....	30
2.5.2 Parameters	30
2.5.3 Cable making.....	31
2.5.4 Device address.....	31
2.6 XINJE XD/XG (Ethernet) series PLC.....	33
2.6.1 Device type.....	33
2.6.2 Parameters	33
2.6.3 Cable making.....	36
2.6.4 Device address.....	37

2.7 XINJE X-NET(Ethernet) series PLC.....	39
2.7.1 Device type.....	39
2.7.2 Parameters	39
2.7.3 Cable making.....	43
2.7.4 Device address.....	44
2.8 ABB PLC.....	46
2.8.1 Device type.....	46
2.8.2 Parameters	46
2.8.3 Cable making.....	47
2.8.4 Device address.....	48
2.9 Allen-Bradley series PLC	49
2.9.1 Device type.....	49
2.9.2 Parameters	49
2.9.3 Cable making.....	51
2.9.4 Device address.....	52
2.10 Bosch Rexroth series PLC.....	53
2.10.1 Device type.....	53
2.10.2 Parameters	53
2.10.3 Cable making.....	58
2.10.4 Device address.....	58
2.11 Delta AS series PLC	59
2.11.1 Device type.....	59
2.11.2 Parameter	59
2.11.3 Cable making.....	62
2.11.4 Device address.....	62
2.12 Delta DVP series PLC.....	64
2.12.1 Device type.....	64
2.12.2 Parameters	64
2.12.3 Cable making.....	64
2.12.4 Device address.....	65
2.13 Delta (temperature controller)	66
2.13.1 Device type.....	66
2.13.2 Parameters	66
2.13.3 Cable making.....	66
2.13.4 Device address.....	66
2.14 Emerson EC20 series PLC	67
2.14.1 Device type.....	67
2.14.2 Parameters	67
2.14.3 Cable making.....	68
2.14.4 Device address.....	69
2.15 Fatek FB series PLC	70
2.15.1 Device type.....	70
2.15.2 Parameters	70
2.15.3 Cable making.....	71

2.15.4 Device address.....	72
2.16 Fuji SPB series PLC	73
2.16.1 Device type.....	73
2.16.2 Parameters	73
2.16.3 Cable making.....	73
2.16.4 Device address.....	74
2.17 HaiWell PLC	75
2.17.1 Device type.....	75
2.17.2 Parameters	75
2.17.3 Cable making.....	75
2.17.4 Device address.....	76
2.18 Haiwell bus TCP.....	77
2.18.1 Device type.....	77
2.18.2 Parameters	77
2.18.3 Cable making.....	78
2.18.4 Device address.....	79
2.19 Hollsys PLC	80
2.19.1 Device type.....	80
2.19.2 Parameters	80
2.19.3 Cable making.....	80
2.19.4 Device address.....	81
2.20 IDEC.....	81
2.20.1 Device type.....	81
2.20.2 Parameters	81
2.20.3 Cable making.....	82
2.20.4 Device address.....	83
2.21 Inovance AM600 PLC	84
2.21.1 Device type.....	84
2.21.2 Parameters	84
2.21.3 Cable making.....	85
2.21.4 Device address.....	85
2.22 Inovance AM600(Ethernet) PLC.....	86
2.22.1 Device type.....	86
2.22.2 Parameters	86
2.22.3 Cable making.....	88
2.22.4 Device address.....	88
2.23 Inovance H2U/H1U PLC.....	89
2.23.1 Device type.....	89
2.23.2 Parameter.....	89
2.23.3 Cable making.....	90
2.23.4 Device address.....	91
2.24 Keyence KV series PLC	92
2.24.1 Device type.....	92
2.24.2 Parameters	92

2.24.3 Cable making.....	92
2.24.4 Device address.....	94
2.25 Keyence KV5000/5500/7500 (Ethernet) series PLC.....	95
2.25.1 Device type.....	95
2.25.2 Parameter setting	95
2.25.3 Cable making.....	98
2.25.4 Device address.....	98
2.26 Koyo Click series PLC	100
2.26.1 Device type.....	100
2.26.2 Parameter setting	100
2.26.3 Cable making.....	101
2.26.4 Device address.....	101
2.27 Koyo Direct Logic (DL) series PLC.....	102
2.27.1 Device type.....	102
2.27.2 Parameters	102
2.27.3 Cable making.....	102
2.27.4 Device address.....	103
2.28 Koyo S series PLC.....	104
2.28.1 Device type.....	104
2.28.2 Parameters	104
2.28.3 Cable making.....	105
2.28.4 Device address.....	106
2.29 LG Master-K series PLC	107
2.29.1 Device type.....	107
2.29.2 Parameters	107
2.29.3 Cable making.....	109
2.29.4 Device address.....	110
2.30 LG Glofa(Cnet) series PLC	111
2.30.1 Device type.....	111
2.30.2 Parameters	111
2.30.3 Cable making.....	113
2.30.4 Device address.....	113
2.31 LG XGB(CPU Direct) series PLC.....	115
2.31.1 Device type.....	115
2.31.2 Parameters	115
2.31.3 Cable making.....	117
2.31.4 Device address.....	118
2.32 LG XGT/XGK(CPU Direct) series PLC	119
2.32.1 Device type.....	119
2.32.2 Parameters	119
2.32.3 Cable making.....	119
2.32.4 Device address.....	120
2.33 LG XGT(Ethernet) series PLC	121
2.33.1 Device type.....	121

2.33.2	Parameter setting	121
2.33.3	Cable making	123
2.33.4	Device address	124
2.34	Mitsubishi FX series PLC	125
2.34.1	Device type	125
2.34.2	Parameters	125
2.34.3	Cable making	126
2.34.4	Device address	126
2.35	Mitsubishi FX BD series PLC (RS232/485)	128
2.35.1	Device type	128
2.35.2	Parameters	128
2.35.3	Cable making	129
2.35.4	Device address	130
2.36	Mitsubishi FX3U/G/GA series PLC	131
2.36.1	Device type	131
2.36.2	Parameters	131
2.36.3	Cable making	132
2.36.4	Device address	132
2.37	Mitsubishi FX5U series PLC	133
2.37.1	Device type	133
2.37.2	Parameter setting	133
2.37.3	Cable making	137
2.37.4	Device address	137
2.38	Mitsubishi Q series PLC	139
2.38.1	Device type	139
2.38.2	Parameters	139
2.38.3	Cable making	142
2.38.4	Device address	143
2.39	Mitsubishi Q02H series	145
2.39.1	Device type	145
2.39.2	Parameters	145
2.39.3	Cable making	148
2.39.4	Device address	149
2.40	Mitsubishi FR series inverter	150
2.40.1	Device type	150
2.40.2	Parameters	150
2.40.3	Cable making	152
2.41	Mitsubishi Melsec 1E(Ethernet) series PLC	153
2.41.1	Device type	153
2.41.2	Parameters	153
2.41.3	Cable making	157
2.41.4	Device address	158
2.42	Mitsubishi Melsec 3E(Ethernet) series PLC	159
2.42.1	Device type	159

2.42.2	Parameter settings.....	159
2.42.3	Cable making.....	163
2.42.4	Device address.....	163
2.43	Mitsubishi SLMP FX5U(Ethernet) series PLC	165
2.43.1	Device type.....	165
2.43.2	Parameters	165
2.43.3	Cable making.....	168
2.43.4	Device address.....	169
2.44	Modbus ASCII (Panel is Master).....	170
2.44.1	Device type.....	170
2.44.2	Parameters	170
2.44.3	Cable making.....	170
2.44.4	Device address.....	171
2.45	Modbus RTU (Panel is Master)	172
2.45.1	Device type.....	172
2.45.2	Parameters	172
2.45.3	Cable making.....	172
2.45.4	Device address.....	173
2.46	Modbus RTU (Panel is Slave)	174
2.46.1	Device type.....	174
2.46.2	Parameters	174
2.46.3	Cable making.....	174
2.46.4	Device address.....	175
2.47	Modbus-TCP device	176
2.47.1	Device type.....	176
2.47.2	Parameter setting	176
2.47.3	Cable making.....	178
2.47.4	Device address.....	179
2.48	OEMax NX7 series PLC	180
2.48.1	Device type.....	180
2.48.2	Device address.....	180
2.48.3	Cable making.....	180
2.48.4	Device address.....	181
2.49	OMRON SYSMAC CP series PLC.....	183
2.49.1	Device type.....	183
2.49.2	Parameters	184
2.49.3	Cable making.....	185
2.49.4	Device address.....	186
2.50	OMRON FinsTCP(Ethernet) CP series PLC.....	188
2.50.1	Device type.....	188
2.50.2	Parameters	188
2.50.3	Cable making.....	190
2.50.4	Device address.....	191
2.51	OPTO 22 SNAP series PLC	192

2.51.1 Device type.....	192
2.51.2 Parameters	192
2.51.3 Cable making.....	192
2.51.4 Device address.....	193
2.52 Panasonic FP series PLC	194
2.52.1 Device type.....	194
2.52.2 Parameters	194
2.52.3 Cable making.....	195
2.52.4 Device address.....	197
2.53 SAIA-Burgess PCD series PLC	198
2.53.1 Device type.....	198
2.53.2 Parameters	199
2.53.3 Cable making.....	199
2.53.4 Device address.....	203
2.54 Sanken VM06 inverter.....	204
2.54.1 Device type.....	204
2.54.2 Parameters	204
2.54.3 Cable making.....	206
2.54.4 Device address.....	206
2.55 Schneider PLC.....	207
2.55.1 Device type.....	207
2.55.2 Parameters	207
2.55.3 Cable making.....	209
2.55.4 Device address.....	209
2.56 SHIMADEN	210
2.56.1 Device type.....	210
2.56.2 Parameters	210
2.56.3 Cable making.....	210
2.56.4 Device address.....	211
2.57 Siemens S7-200 series PLC.....	212
2.57.1 Device type.....	212
2.57.2 Parameters	212
2.57.3 Cable making.....	213
2.57.4 Device address.....	214
2.58 Siemens S7-300/400 series PLC.....	215
2.58.1 Device type.....	215
2.58.2 Parameters	215
2.58.3 Cable making.....	217
2.58.4 Device address.....	217
2.59 Simens S7-200 smart (Ethernet) series PLC	218
2.59.1 Device type.....	218
2.59.2 Parameters	218
2.59.3 Cable making.....	220
2.59.4 Device address.....	221

2.60 Siemens S7-300 (Ethernet) series PLC	223
2.60.1 Device type.....	223
2.60.2 Parameter setting	223
2.60.3 Cable making.....	225
2.60.4 Device address.....	226
2.61 Siemens S7-1200 (Ethernet) series PLC.....	228
2.61.1 Device type.....	228
2.61.2 Parameters	228
2.61.3 Cable making.....	234
2.61.4 Device address.....	235
2.62 TAIAN series PLC.....	236
2.62.1 Device type.....	236
2.62.2 Parameters	236
2.62.3 Cable making.....	236
2.62.4 Device address.....	237
2.63 VIGOR VB/VH series PLC.....	238
2.63.1 Device type.....	238
2.63.2 Parameters	238
2.63.3 Cable making.....	238
2.63.4 Device address.....	239
2.64 VIGOR VS series PLC	241
2.64.1 Device type.....	241
2.64.2 Parameters	241
2.64.3 Cable making.....	242
2.64.4 Device address.....	243
2.65 YuDian AI.....	244
2.65.1 Device address.....	244
2.65.2 Parameters	244
2.65.3 Cable making.....	245
2.65.4 Device address.....	245
2.66 CODESYS PLC.....	246
2.66.1 Device type.....	246
2.66.2 Parameters	246
2.66.3 Cable making.....	249

1 Description

This chapter will introduce the serial port of HMI.

1.1 Serial port of HMI

Series	Download port			PLC port			Expand port	Ethernet port ^{※1}
	RS232	RS485	RS422	RS232	RS485	RS422	RS485	RJ45
TP Series	√	√		√	√	√		
TH Series	√ ^{※2}	√ ^{※2}		√	√	√	√ ^{※3}	
TG Series	√ ^{※4}	√ ^{※4}		√ ^{※5}	√ ^{※5}	√ ^{※5}		√
TE Series ^{※6}	√	√		√	√	√		√
TN Series ^{※7}	√	√	√		√			√

※1:ET and NT models of TG/TE/TN series are equipped with Ethernet port.

※2:TH465-MT/UT have no such communication port.TH465-MT2/UT2 only support RS232.

※3:only TH765-N3/NU3 have expand port(discontinued).

※4:TG465-MT/UT/XT and TG765-XT/XT-C have no such communication.TG765S-XT only supports RS232.

※5:TG465-XT and TG465-MT/UT with hardware version below V3.0 only support RS232/RS485. TG765-XT-C and TG765S-XT only support RS232.

※6:The model of TE series is only TE765-MT/UT/ET.

※7:The ET model of TN series (special for X-NET bus) has been renamed as -NT model corresponding to TG series, and other models have been discontinued.

Take the communication interface of TG765-ET as an example:

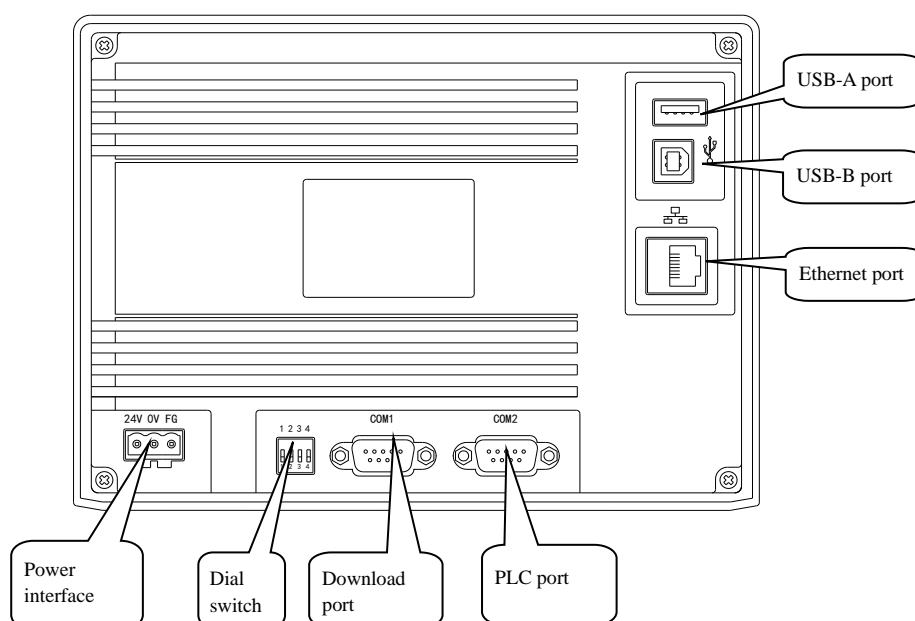

1.1.1 Download port

Download port:

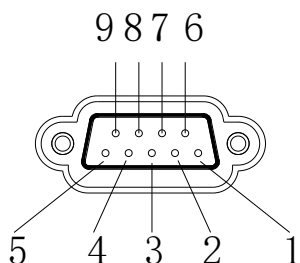

Pin	Name	Explanation
1	NC	Vacant
2	RXD	RS232 receive
3	TXD	RS232 send
4	A	RS485 +
5	GND	Ground
6	NC	Vacant
7	B	RS485 -
8	NC	Vacant
9	NC	Vacant

Only TN series download port supports RS422 (refer to chapter 1.1.2 for pin definition). Other types of HMI cannot directly communicate with Mitsubishi FX/FX3U/FX3G Series CPU port and other RS422 devices. If you need to communicate with Mitsubishi FX/FX3U/FX3G series PLC, you can add 232 / 485 BD board to PLC or use Mitsubishi original programming cable.

1. Choose the device to communicate with download port

(a) Build a new project in Touchwin software, choose download port device.

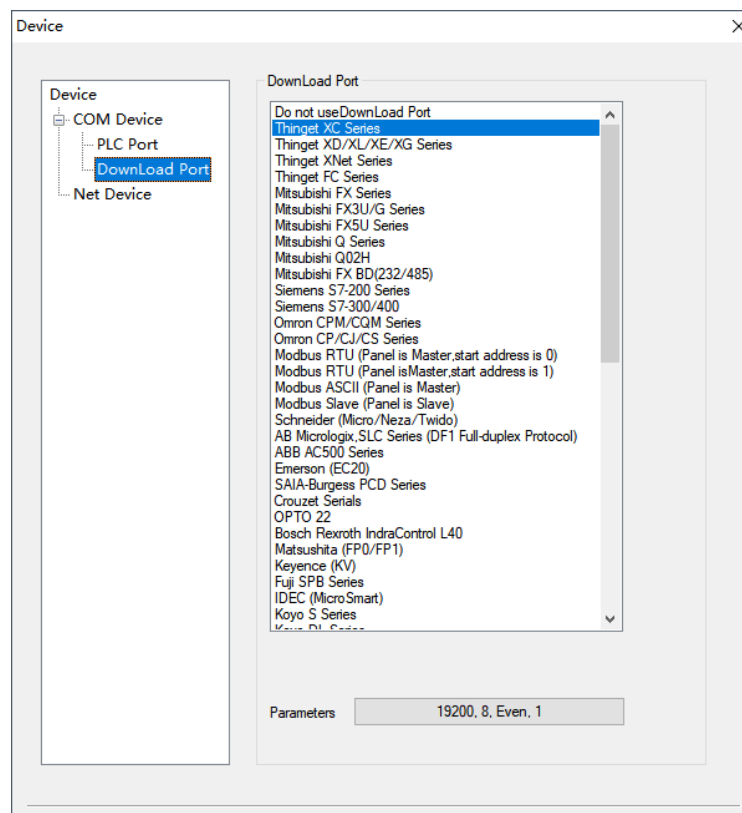

(b) For current project, please set it in the Touchwin software:

click "file/Setting/Device/Serial port equipment/Download port" to view or modify the PLC communication parameters. It is recommended not to directly switch the PLC type. If the PLC type has been switched, please

check the address and station number of each component again.

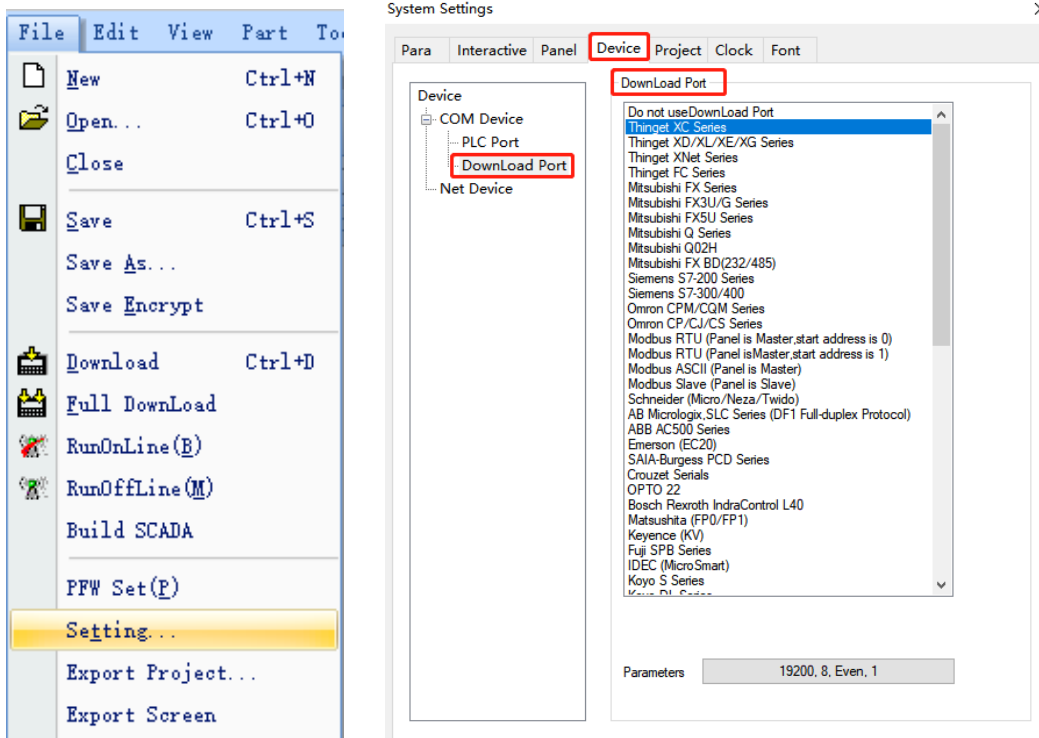

2. Mode switching for download port

The default mode of TH/TG/TE/TN series download port is communication. But it is download mode for TP series. If the download port of TP series needs to switch to communication mode, two pins of the download port must be shorted. Please see the following diagram.

- (1) Cut off the power of TP series HMI, connect pin5 and pin6 of TP download port.
- (2) Power on the HMI, take away the connection cable, the download port will be in communication mode.

pin	name
1	NC
2	RXD
3	TXD
4	A
5	GND
6	BUSY
7	B
8	NC
9	NC

Note:

1. If the HMI needs to download program, please restart the HMI.
2. Please connect the pin 5 and 6 directly.

1.1.2 PLC port

PLC port:

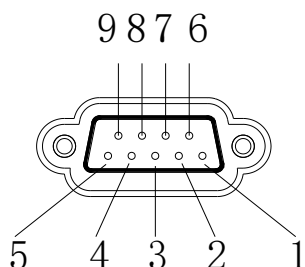

Pin	Name	Explanation
1	TD+	RS422 send -
2	RXD	RS232 receive
3	TXD	RS232 send
4	A	RS485 +
5	GND	Ground
6	TD-	RS422 send -
7	B	RS485 -
8	RD-	RS422 receive -
9	RD+	RS422 receive +

RS422:
1、5、6、8、9

Note:

TG465-MT/ UT (version below V3.0) PLC port only supports RS232/RS485, TG765-XT/XT-C and TG765S-XT PLC ports only support RS232, and TN series PLC port only supports RS485.

In practical application, please refer to Chapter 2 for the production of communication cable, and refer to section 1.1.1 download port for the selection and modification of communication equipment.

1.1.3 Expand port

Expand port:

Pin	Definition	Explanation
1	A	RS485 +
2		
3		
4		
5		
6	B	RS485 -
7		
8		
9		

Note: only TH765-NT3/NU3 has this expand port.

1. choose expand port device

(1) Build a new project, click expand port, and choose the device

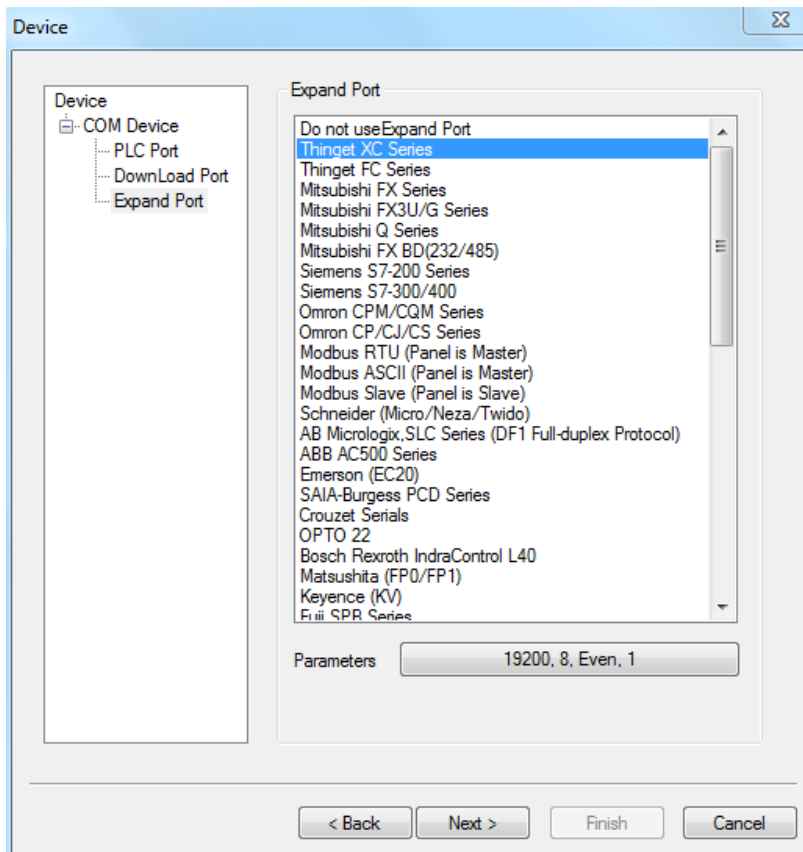

(2) For existed project, click File/setting/device/expand port to set the PLC model.

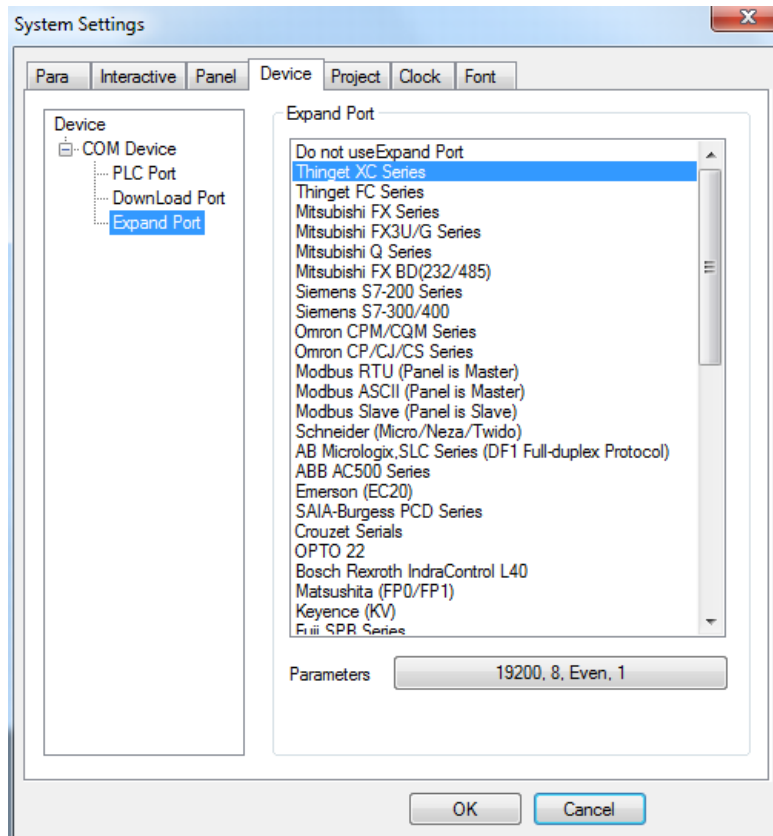

1.1.4 Ethernet port

RJ45 Ethernet port:

Pin	Color	Definition	Explanation
1	Orange white	TXD+	Data send+
2	Orange	TXD-	Data send-
3	Green white	RXD+	Data receive+
4	Blue	-	-
5	Blue white	-	-
6	Green	RXD-	Data receive-
7	Brown white	-	-
8	Brown	-	-

Note: only TG(-ET/NT), TE(-ET) and TN(-ET) have Ethernet port.

1. Build a new project, choose TG model in the list.

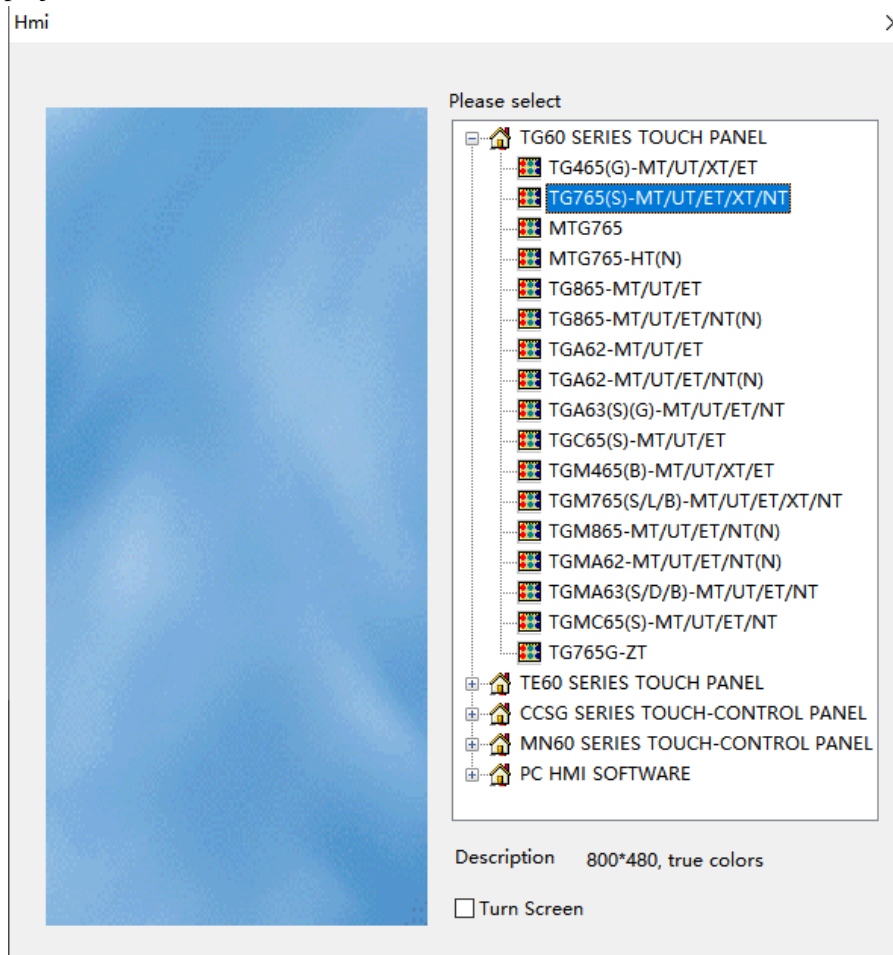

2. Click next, choose net device. Set the IP address of TG series HMI.

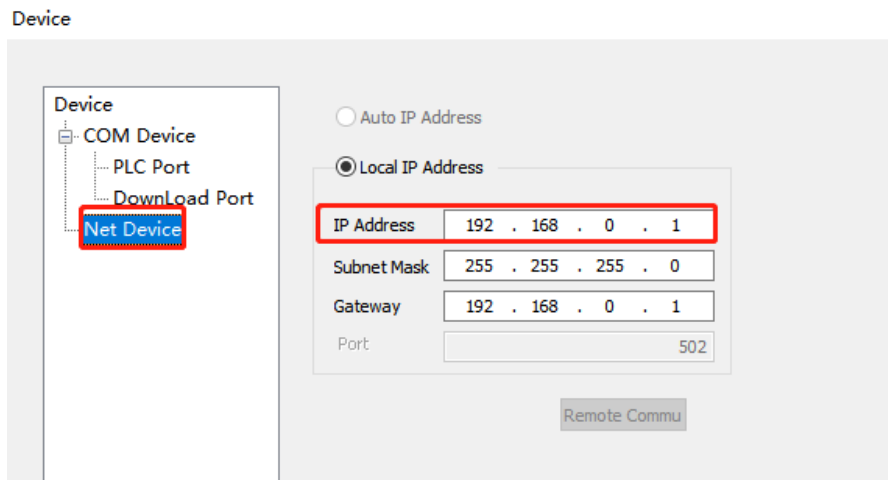

3.Right click net device, build a new Ethernet device.

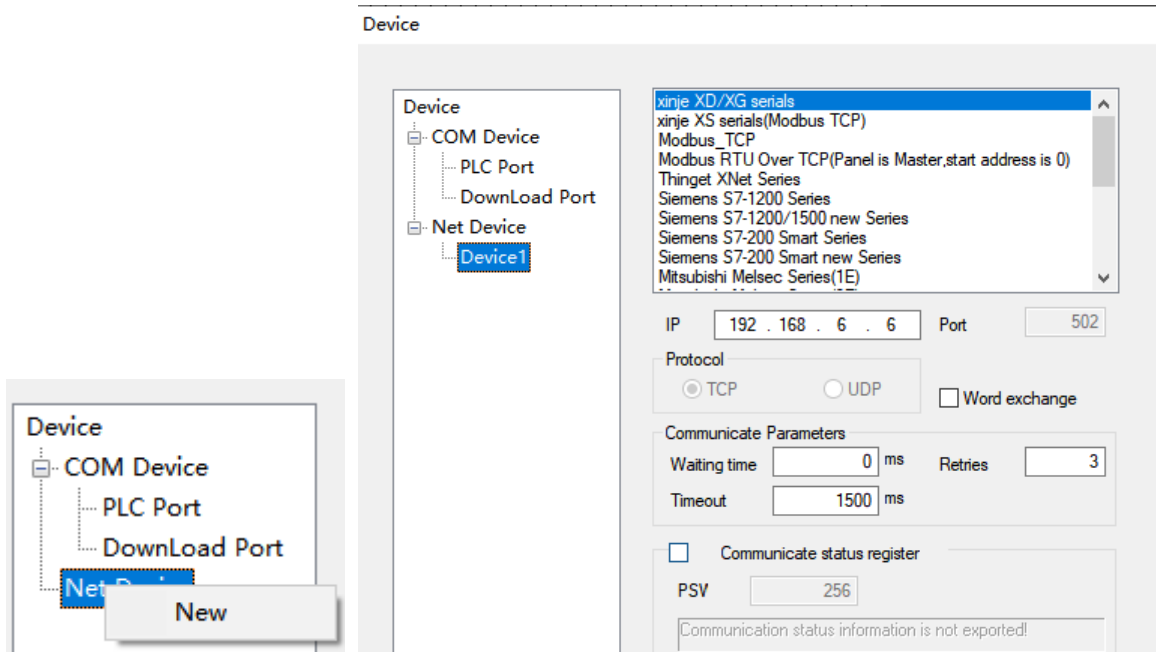

Note:

- (1) this function support local area network, but not support wide area network.
- (2) The Ethernet protocol only supports the protocols listed above, and other protocols are under continuous development.

1.2 Communication precautions

1.2.1 Selection of communication driver (protocol)

Select the corresponding driver (protocol) before communication, programming, and then program. Refer to the following instructions to select the driver (protocol):

1. Whether the device can be directly selected in the software device list.
2. If this device is not available in the list, check whether the device supports Modbus RTU protocol or Modbus ASCII protocol.

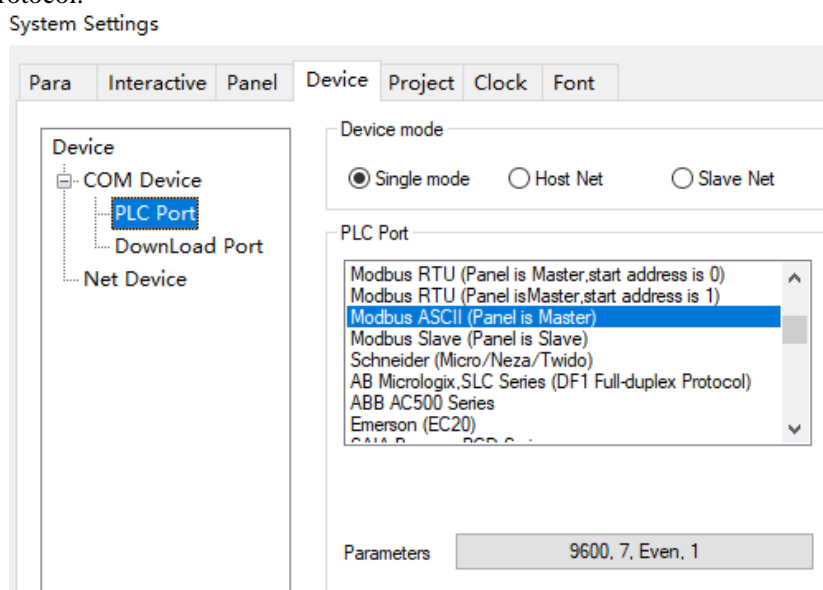

3. If neither of the above two conditions is met, choose to communicate freely through the C script function in the software.

Note: when communicating with the lower machine through the C script, the PLC port, the download port, the expansion port, the Modbus slave (slave display) and the free model (slave display) are not available. Other protocols can be selected at will as long as the communication parameters are consistent.

1.2.2 Communication parameter description

1. Baud rate, data bit, stop bit and check sum shall be consistent with PLC.
2. Delay time is used for one screen with multiple computers (that is, one communication port of a touch screen is connected to multiple PLCs through RS485). There is no fixed value. Generally, it is about 20 for two devices. The appropriate delay time is gradually adjusted according to the number of devices added.
3. Retry time: the default value is 3. When the command is sent three times in a row, and the slave does not respond, the touch screen considers the communication failure and continues to access the next parameter.
4. Word exchange: when the dual word monitoring is inconsistent with the PLC, observe whether the high and low words are reversed. If so, check this option to realize the high and low word exchange of dual words.

2 The connection of PLC and HMI

This chapter will introduce the connection between PLC and HMI.

Please don't pull out or plug the cable when power on, the serial port may be damaged.

When the software version of the touch screen is upgraded, the address range of the communication protocol equipment will be partially changed, and the address range of the equipment in the software shall prevail.

2.1 XINJE FC series PLC

2.1.1 Device type

Series	CPU	Connected module	Port	Cable making	PLC model in Touchwin software
FC	FC-14/16/24/32R/T-E/C	CPU direct connection	RS232	Fig1	Xinje FC series
			RS485	Fig2	

2.1.2 Parameters

HMI parameters:

Parameters	Settings	Choices for settings	Item
PLC type	FC series		
Port	RS232	RS232or RS485	
Data bit	8	7 or 8	
Stop bit	1	1 or 2	
Parity	Odd parity	Odd/even/no parity	
Baud rate	9600	4800/38400/9600/115200/19200/187500	
Station No.	0	0~255	

The default communication parameters of FC: 9600, 8, 1, odd parity, station No.0.

2.1.3 Cable making

(a) Connect to FC series CPU (RS232 port)

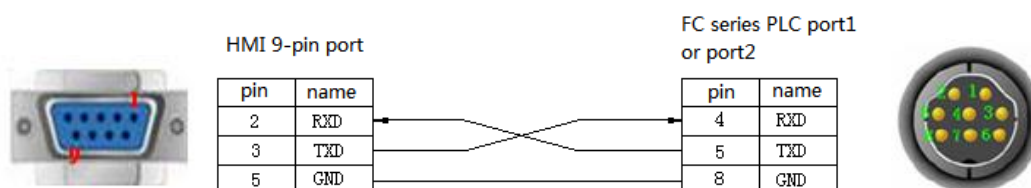

Fig1

(b) Connect to FC series PLC CPU (RS485 port)

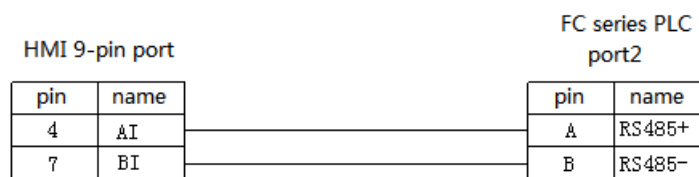

Fig2

2.1.4 Device address

PLC address	Range	Data type	Explanation
X	0~337	Bit	External input coil
Y	0~337	Bit	External output coil
M	0~383	Bit	Internal coil
SM	0~96	Bit	Special coil
T	0~128	Bit	Timer
C	0~128	Bit	Counter
W	0~2047	Word/DWord	Data register
FW	0~191	Word/DWord	FlashROM register
TW	0~127	Word/	Timer register
CW	0~127	Word/	Counter register
SW	0~111	Word//DWord	Special register
WX	0~13	Word//DWord	Input coil register
WY	0~13	Word//DWord	Output coil register
WM	0~23	Word//DWord	Interla coil register

2.2 XINJE XC series PLC

2.2.1 Device type

Series	CPU	Connected module	Port	Cable making	PLC model in Touchwin software
XC	XC1/XC2/ XC3/XC5/ XCC/XCM	CPU direct connection	RS232	Fig1 or Fig2	Xinje XC series
			RS485	Fig 3	
		XC-COM-BD (communication extension board)	RS232	Fig 4	
			RS485	Fig 5	

2.2.2 Parameters

HMI parameters:

Parameter	Recommend settings	Choices of settings	Item
PLC type	XC series	FC/XC series	
Port	RS232	RS232 or RS485	
Data bit	8	7 or 8	
Stop bit	1	1 or 2	
Parity	Even parity	Even/odd/no parity	
Baud rate	19200	4800/38400/9600/115200/19200/187500	
Station No.	1	0~255	

The default communication parameters of XC: 19200, 8, 1, even, station No.1.

PLC settings:

Open XCPpro software:

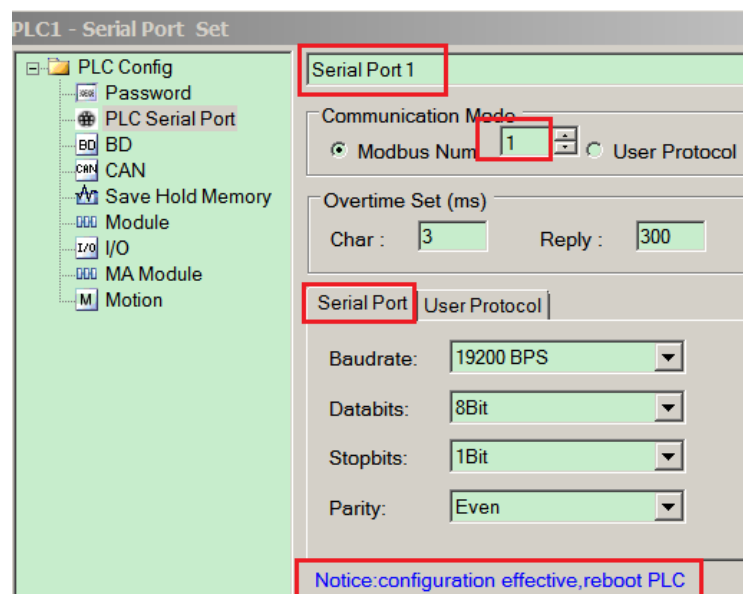

2.2.3 Cable making

(a) Connect to XC series PLC CPU (RS232 port)

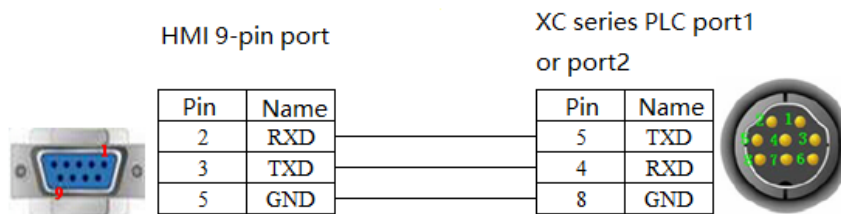

Fig 1

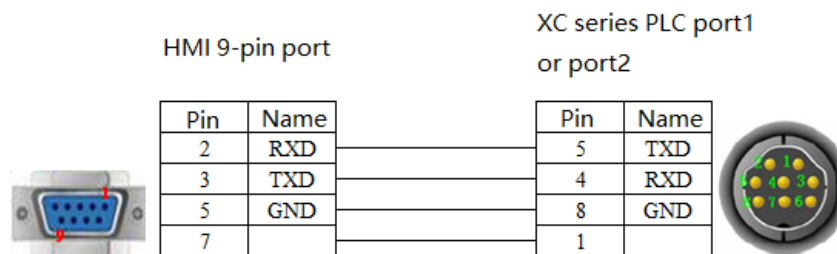

Fig 2

Note: XP3-16 must use the communication line shown in Fig2 (XVP line) when downloading program.

(b) Connect to XC series PLC CPU (RS485 port)

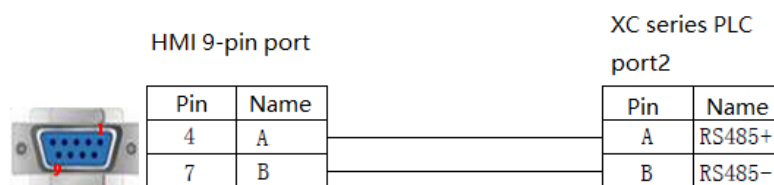

Fig 3

(c) Connect via XC-COM-BD (RS232)

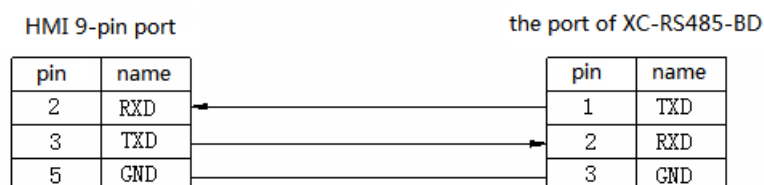

Fig 4

(d) Connect via XC-COM-BD (RS485)

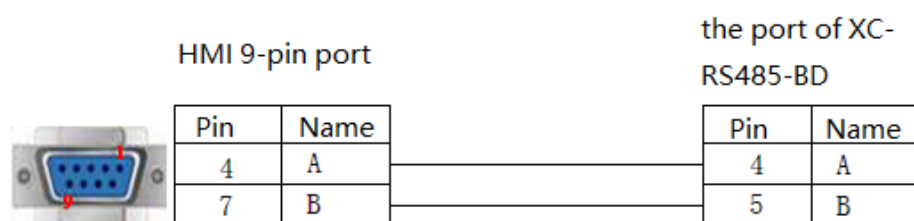

Fig 5

2.2.4 Device address

PLC address	Range	Data type	Explanation
X	0~543	Bit	External input coil
Y	0~543	Bit	External input coil
M	0~7999	Bit	Internal coil
S	0~1023	Bit	Internal coil
M8XXX	0~511	Bit	Internal special register
T	0~639	Bit	Timer
C	0~639	Bit	Counter
D	0~7999	Word//DWord	Data register
TD	0~639	Word//DWord	Timer register
CD	0~639	Word//DWord	Counter register
D8XXX	0~511	Word//DWord	Special register
FD	0~1535	Word//DWord	FlashROM register
FD8XXX	0~511	Word//DWord	Output register
ED	0~36862	Word//DWord	Extend register
DM	7984	Word	Data register
DX	0~52	Word	Data register
DY	0~52	Word	Data register
DS	0~1008	Word	Data register
DM8XXX	0~496	Word	Data register
DT	0~603	Word	Data register
DC	0~619	Word	Data register
ID	0~9999	Word//DWord	Analog input
QD	0~9999	Word//DWord	Analog output

2.3 XINJE XD/XL/XG series PLC

2.3.1 Device type

Series	CPU	Connected module	Port	Cable making	PLC model in Touchwin software
XD/XL/XG	XD/XDM/XDH/ XDC/XL/XG	CPU direct connection	RS232	Fig1 or Fig2	Xinje XD/XL/XE/XG series
			RS485	Fig 3	

2.3.2 Parameters

HMI parameters:

Parameter	Recommend settings	Choices of settings	Item
PLC type	XD/XL/XE/XG series	Xinje XD/XL/XE/XG Series / Modbus RTU(Panel is Master)/ Modbus ASC II (Panel is Master)	
Port	RS232	RS232 or RS485	
Data bit	8	7 or 8	
Stop bit	1	1 or 2	
Parity	Even parity	Even/odd/no parity	
Baud rate	19200	4800/38400/9600/115200/19200/187500	
Station No.	1	0~255	

PLC settings:

(1) PLC protocol type selecting: XINJE XD/XL/XE/XG series or Modbus RTU(panel is master)

PLC1 - Serial Port Set

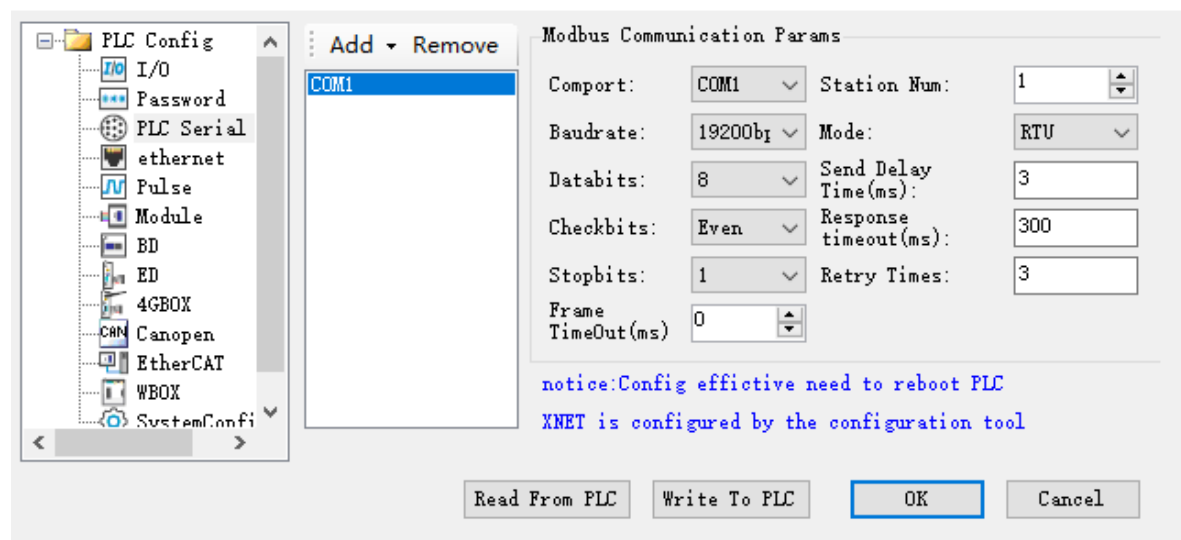

(2) PLC protocol type selecting: Modbus ASC II (panel is master)

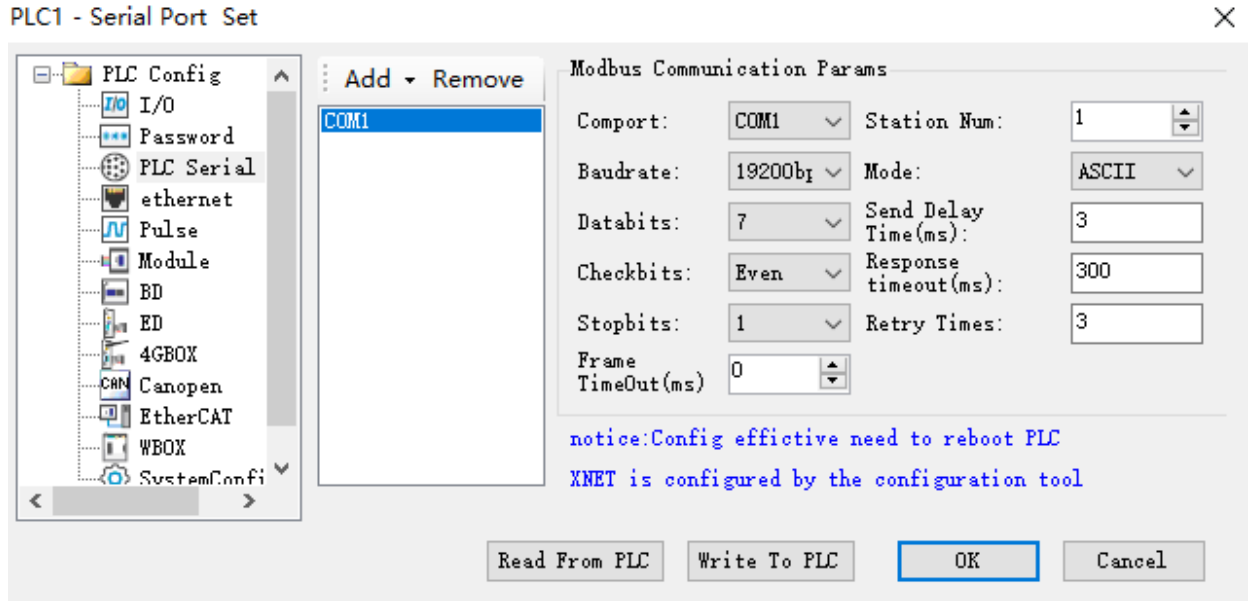

2.3.3 Cable making

(a) Connect to XD/XE series PLC CPU (RS232 port)

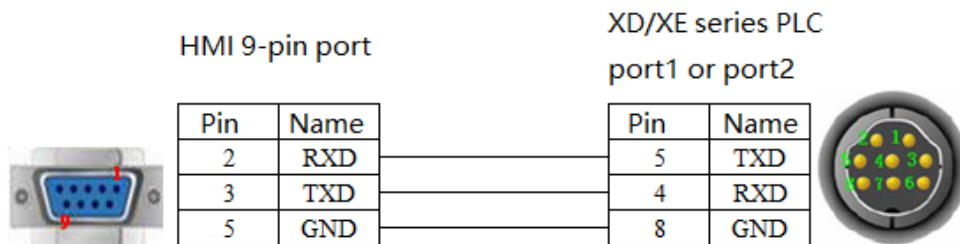

Fig 1

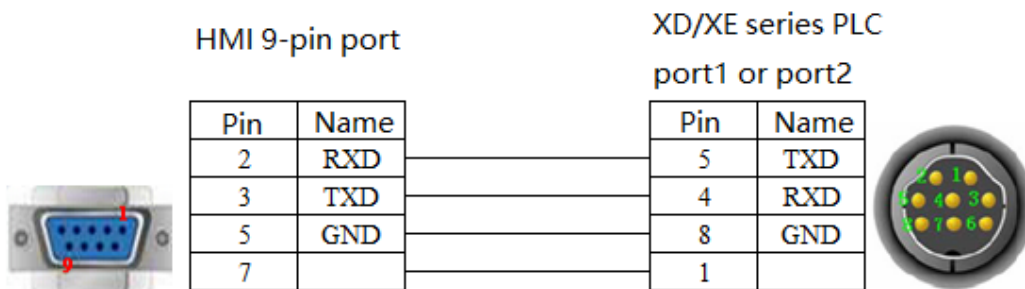

Fig 2

Note: XP3-16 must use the communication line shown in Figure 2 (XVP line) when downloading program.

(b)Connect to XD/XE series PLC CPU (RS485 port)

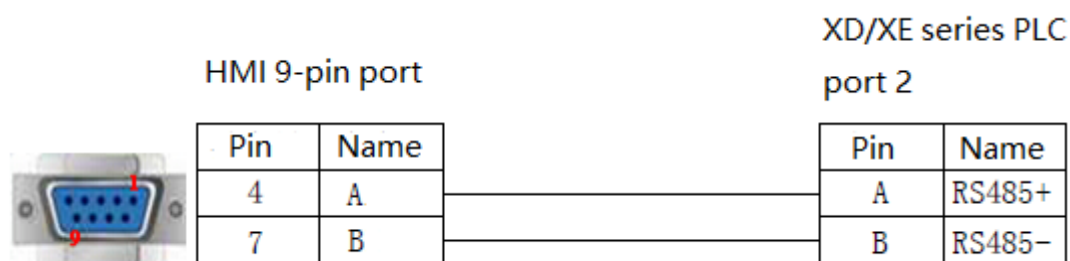

Fig 3

2.3.4 Device address

PLC address type	Range	Object type	Explanation
X	0~77	Bit	Input relay
X1 xxxx	0~1777	Bit	Extended module input relay
X2 xxxx	0~477	Bit	Extended BD input relay
Y	0~77	Bit	Output relay
Y1 xxxx	0~1777	Bit	Extended module output relay
Y2 xxxx	0~477	Bit	Extended BD output relay
M	0~7999	Bit	Internal relay
S	0~1023	Bit	Flow
SM	0~2047	Bit	Internal relay, special using
T	0~575	Bit	Timer
C	0~575	Bit	Counter
ET	0~31	Bit	Timer, precise timer
SE	0~31	Bit	Sequence block wait instruction special coil
HM	0~959	Bit	Internal relay, power-off retentive
HS	0~127	Bit	Flow, power-off retentive
HT	0~95	Bit	Auxiliary relay, power-off retentive
HC	0~95	Bit	Counter, power-off retentive
HSC	0~31	Bit	Counter, high speed counter
D	0~7999	Word/DWord	Data register
ID	0~99	Word/DWord	Analog input
ID1xxxx	0~1599	Word/DWord	Extended module analog input
ID2xxxx	0~499	Word/DWord	Extended BD analog input
QD	0~99	Word/DWord	Analog output
QD1xxxx	0~1599	Word/DWord	Extended module analog output
QD2xxxx	0~499	Word/DWord	Extended BD analog output
SD	0~2047	Word/DWord	Data register, special using
TD	0~575	Word/DWord	Timer value
CD	0~575	Word/DWord	Counter value

ETD	0~31	Word/DWord	Timer value, precise timer
HD	0~999	Word/DWord	Data register
HSD	0~499	Word/DWord	Data register, power-off retentive
HTD	0~95	Word/DWord	Timer value, power-off retentive
HCD	0~95	Word/DWord	Counter value, power-off retentive
HSCD	0~31	Word/DWord	Counter value, high speed counter
FD	0~6143	Word/DWord	FlashROM register
SFD	0~1999	Word/DWord	FlashROM register, special using
FS	0~47	Word/DWord	Special security register
DM	0~7984	Word	For data register
DX	0~60	Word	For data register
DX1xxxx	0~1760	Word	For data register, extended module
DX2xxxx	0~460	Word	For data register, extended BD
DY	0~60	Word	For data register
DY1xxxx	0~1760	Word	For data register, extended module
DY2xxxx	0~460	Word	For data register, extended BD
DS	0~1008	Word	For data register
DSM	0~2032	Word	For data register, special function using
DT	0~560	Word	For data register
DC	0~560	Word	For data register
DET	0~16	Word	For data register, precise timer
DSE	0~16	Word	For data register, WAIT instruction
DHM	0~944	Word	For data register, power-off retentive
DHS	0~112	Word	For data register, power-off retentive
DHT	0~80	Word	For data register, power-off retentive
DHC	0~80	Word	For data register, power-off retentive
DHSC	0~16	Word	For data register, high speed counter

2.4 XINJE X-NET communication

X-NET bus is the bus protocol between TG/TE series HMI and XD series PLC. The TG series -NT model is a dedicated screen for bus communication, which has faster communication speed and better networking performance. It is recommended to choose -NT model when bus communication.

Note:

(1)The bus communication of the original TN series is the same as that set here.

(2)TP/TH series and TG765G-ZT do not support X-NET protocol.

2.4.1 Device type

Series name	CPU unit	Connection module	Communication type	Cable making	PLC model in Touchwin software
XD/XL/ XG	XD/XDM/XDC/ XDH/XL/XG	CPU direct connect extension BD module	RS485	Fig 1 or 2	Xinje XNet series
			RS232	Fig 3	

2.4.2 HMI setting

Parameters	Recommended setting	Optional setting	Notes
PLC type	Xinje Xnet series		1. PLC station no. must be 2 and baud rate must be 57600 for auto matching 2. -NT model has no RS232 for PLC port 3. Only -NT PLC port has a maximum baud rate of 3M. For other models, the baud rate of serial port is up to 115200.
Communication port	RS485	RS485/RS232	
Data bit	8		
Stop bit	1		
Parity	Even parity		
Auto match baud rate	57600	57600	
Set baud rate manually	57600	9600~3M	
Stataion no.	1	1~100	

X-NET bus includes two connection modes: OMMS mode and TBN mode.

OMMS mode is supported by TG/TE series(single HMI mode including one HMI one device, one HMI multi-device). TBN mode is supported by NT model(multi-HMI mode including multi-HMI one device, multi-HMI multi-device). The XD series PLC must be hardware V3.2.2 and later. The download port and PLC port is separate for TG/TE series HMI.

2.4.2.1 OMMS mode

OMMS mode includes auto match and manual setting.

If auto match is selected, there is no need to set the parameters, this mode is fit for one HMI one device communication, and the PLC station no. should be no.2, baud rate must be 57600 bps. (Note:The default network number is 32769.)

The default is manual setting mode if auto match is not selected. In this case, it needs to use xinje config tool to set the HMI parameters, PLC station no. and baud rate are not limited, please choose them as you need.

1. Auto match

Touchwin software can automatic set the communication parameters in auto match mode, only TG/TE series HMI PLC port OMMS mode support auto match mode.

(a) When building the HMI program, PLC port please choose xinje Xnet series, PLC port device please choose auto match, other no needs to set.

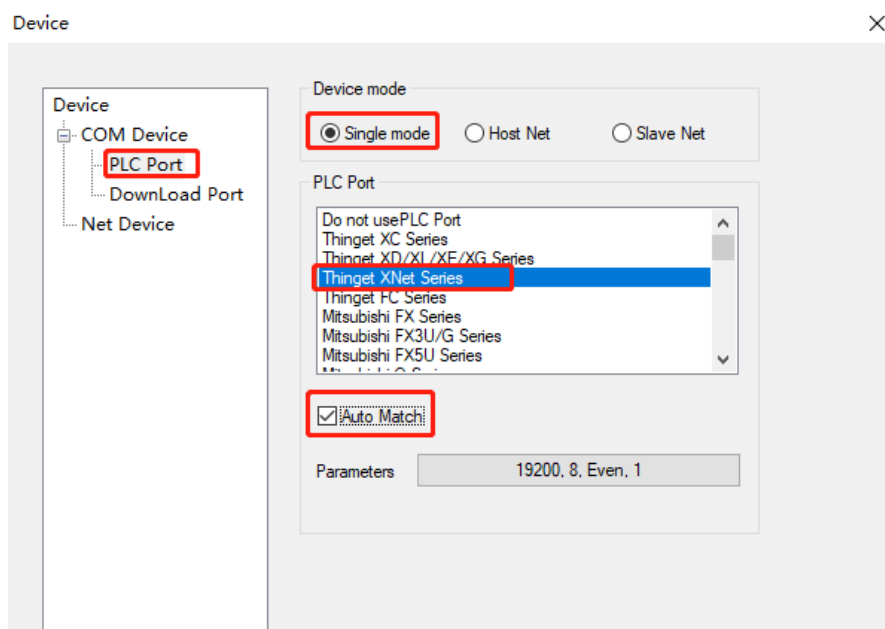

(b) PLC serial port needs to set corresponding parameters

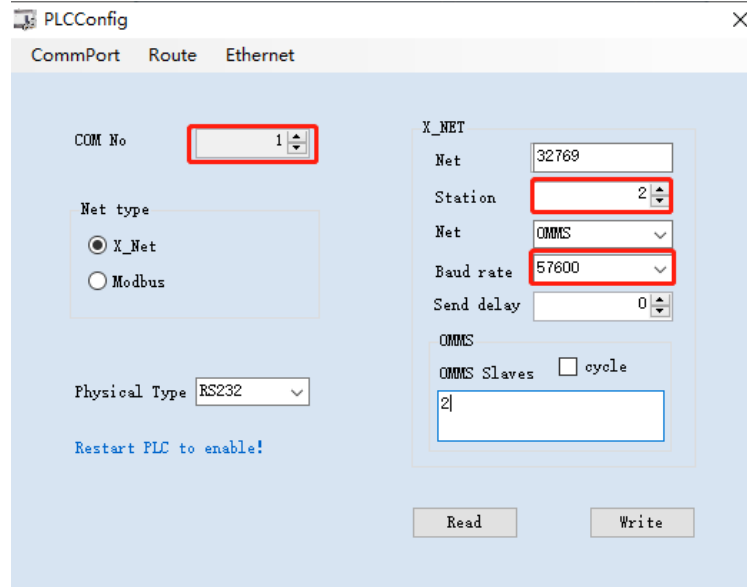

(c)After writing the configuration, the PLC needs to be restarted before all configurations take effect.

2. Manual set

- (1) make a new HMI program, the download port please set to xinje Xnet series, PLC port please set to xinje Xnet series, the screen contents can be anything, and download the program in the HMI.
- (2) connect the download port of HMI with PC, power on the HMI.
- (3) open xinje config tool, click “find device”.
- (4) choose the com port, which is the PC serial port, it will show the config tool main interface after the connection is normal.

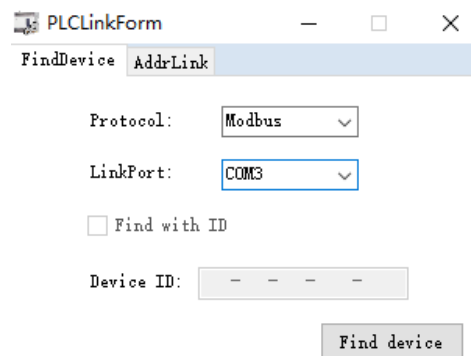

If the connection fails, a connection failure window will pop up. Please check whether the RS232 serial port line is wrong and close other software that occupies the serial port. The bus can be initialized if cannot connecting, set ON switch 4 on the back of the touch screen, restart the touch screen, and download the newly created program again. After the download, set OFF switch 4, and then repeat the connection operation.

- (5)After the connection is successful, click net type:X_Net
- (6) set the serial port parameters and net id, click write config and close the window.

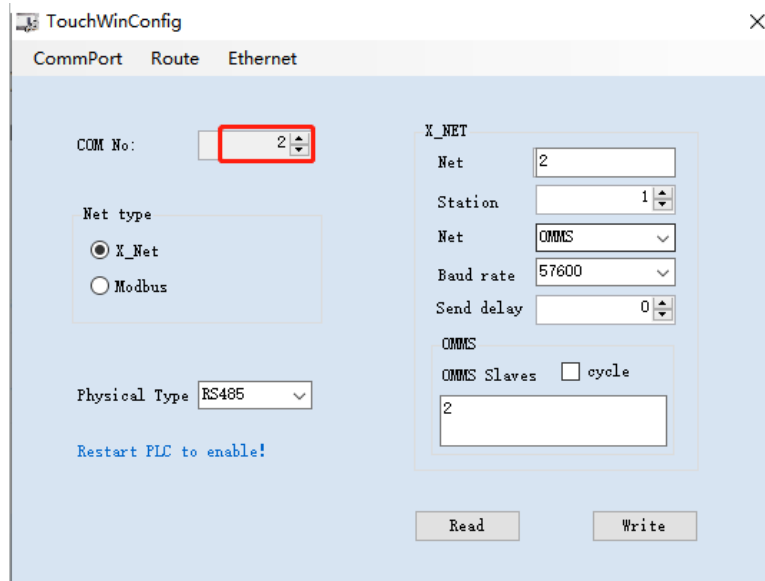

Com port no.: 1 means HMI download port, 2 means HMI PLC port.

Choose Net: please choose X-NET.

Choose PHY(physical layer): RS232 communication (-NT model PLC port not support), RS485 communication.

Net ID: the communication network no., all the devices in the same network should have the same network no., the range is 1 to 32767.

Station no.: it must be 1 for OMMD mode HMI station no.

Net type: please choose OMMS mode (which is single HMI mode)

Baud rate: the max baud rate is 115200 for TG/TE series PLC port, download port, and -NT model download port, the max baud rate is 3M for -NT model PLC port.

Cycle: please choose this when PLC supports motion bus.

OMMS_slaver list: all the slave station no. connecting the HMI. For example, one HMI connects two PLCs, the station no. of the two PLCs are 2 and 3, it must set 0,2,3 here. Otherwise it will not communicate.

(7) click “Route”.

(8) First please read the HMI setting, then choose add item, set the parameters, then click write.

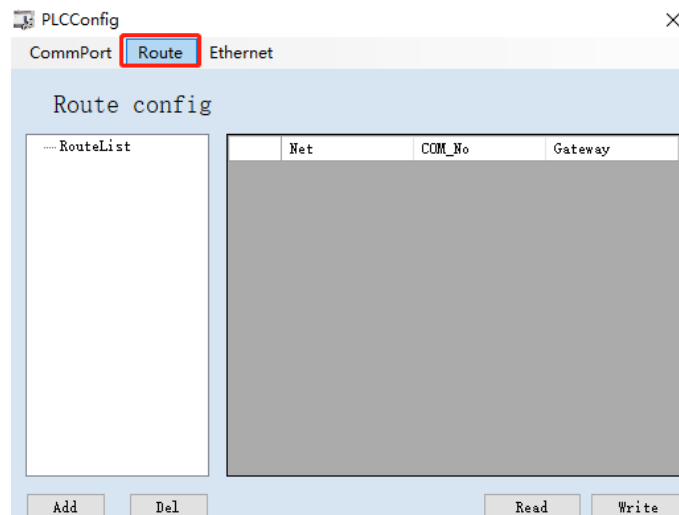

Net: the net id in the serial port setting.

Com no.: com port no. in the serial port setting.

Gateway: it is 0 in the same network. For cross network communication, it is the station no. that the cross network transfer equipment signal accesses the serial port.

(note: cross network communication must be PLC hardware v3.3 and up)

After setting, please restart the HMI to make the setting effective.

2.4.2.2 TBN mode

Only –NT model supports this mode. Repeat OMMS mode manual step 1 to 5.

(6) set the serial port parameters and net id, click write config and close the window.

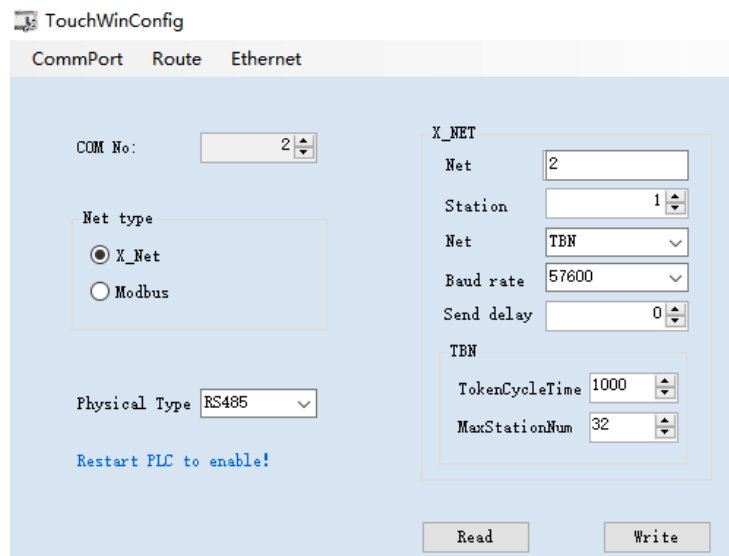

Com port no.: 1 means HMI download port, 2 means HMI PLC port.

Choose Net: please choose X-NET.

Choose PHY(physical layer): RS232 communication (-NT model PLC port not support), RS485 communication.

Net ID: the communication network no., all the devices in the same network should have the same network no., the range is 1 to 32767.

Station no.: set any station no. for the PLC and HMI in the network.

Net type: please choose TBN mode (which is multi-HMI mode)

Baud rate: the max baud rate is 115200 for-NT model, the max baud rate is 3M for –NT model PLC port.

Token cycle time: the longest time the token passes one circle. The default time is 1000ms.

Max station no.: It refers to the largest station number in a network, and the communication token will be searched from station 1 to the largest station number. Considering the communication speed, it is suggested that the customers choose the continuous station number when assigning station number, and the largest station number cannot exceed 100.

(7) click route

(8) first please read the HMI setting, then choose add item, set the parameters, then click write.

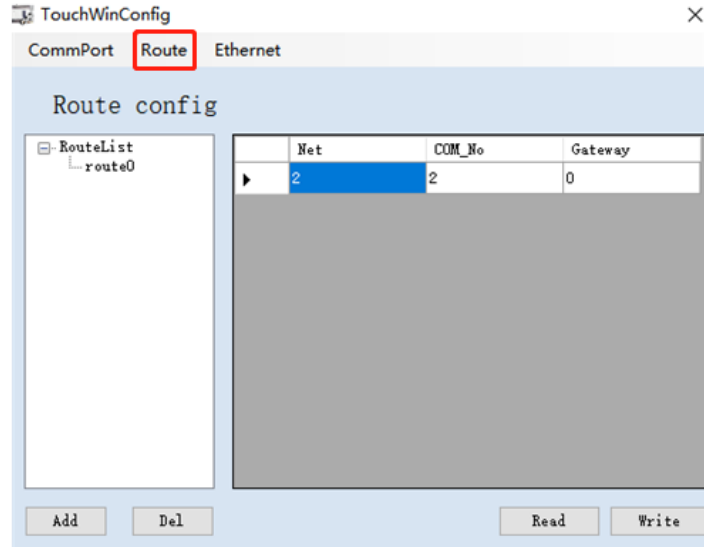

After setting, please restart the HMI to make the setting effective.

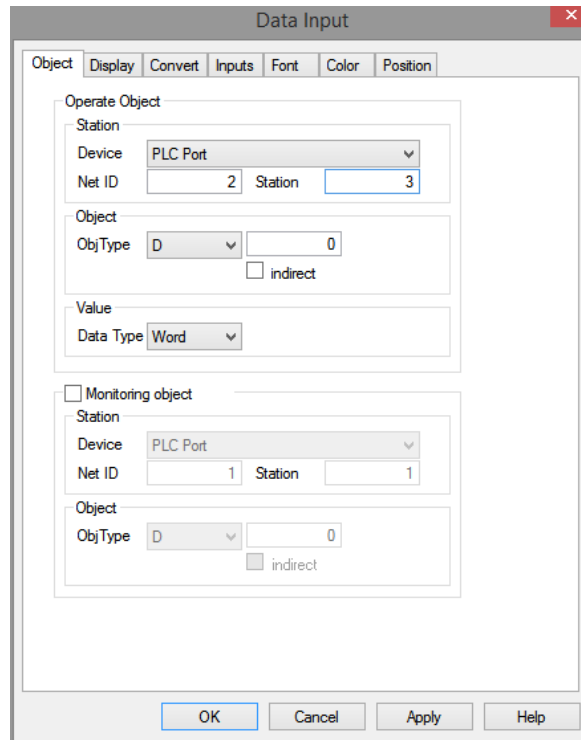

Note: in the HMI program, the Net ID corresponds to the net number in the serial port configuration, station corresponds to the station number in the serial port configuration.

2.4.3 XD series PLC setting (PLC hardware V3.2.2 and up)

Connect the PLC to the computer through USB cable or port1, power the PLC, and repeat the OMMS manual configuration step 3-5. If PLC and computer communication is not normal, the corresponding error message will appear. At this time, you need to restart Config software and start the configuration again until the error message below appears.

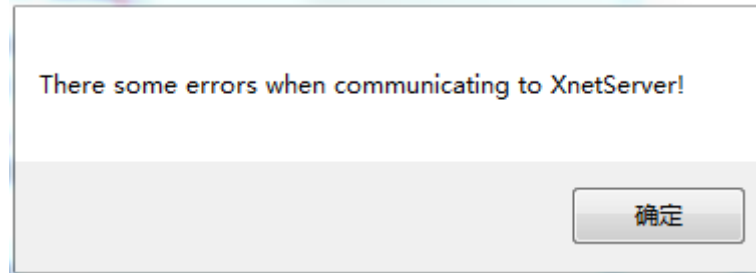

(6)Set the serial port parameters, net id, then click write config and close the window.

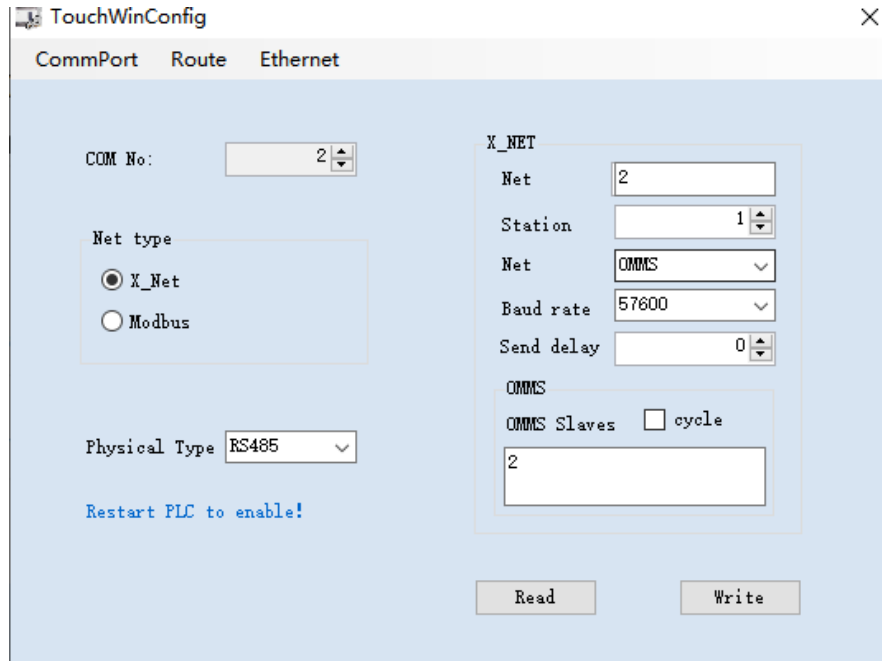

Fig1 OMMS mode

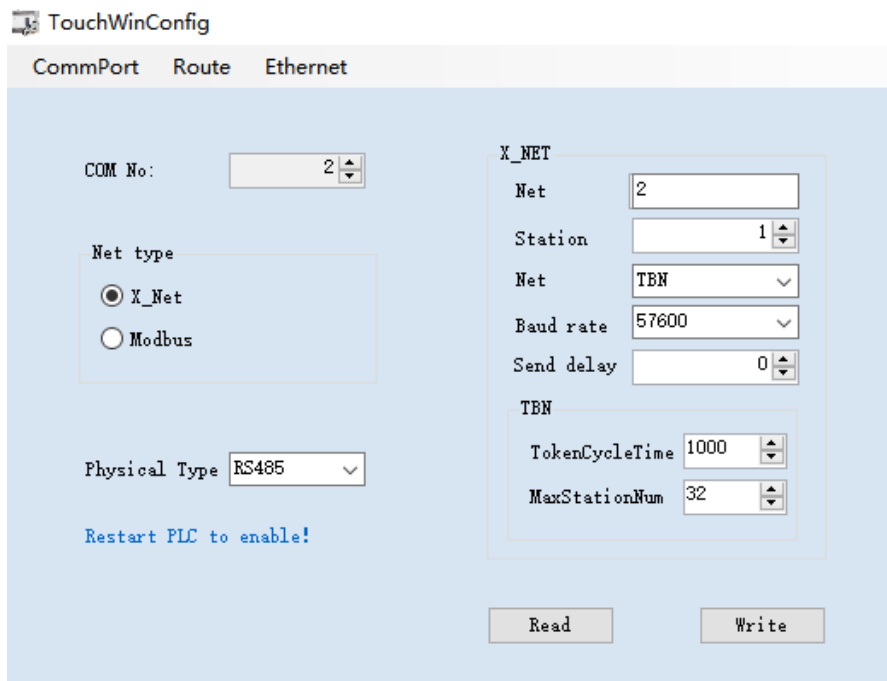



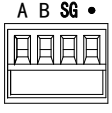

Fig2 TBN mode

Serial port: PLC port no., please set as actual connection port no.

XD series PLC port definition and functions:

Port	Appearance	Port definition	Serial port no.
Port1		RS232 port	1
Port2	A, B	RS485 port	2
USB		USB port	
Port3		Left extension ED port	3
Port4 Port5	 Up extension BD (left Port4, right Port5)	RS232 port/RS485 port/optical fiber port	4, 5

Station no.: the PLC station no. in the network, the range is 1 to 100. The operate object station no. in the HMI corresponds to this station no. note: the PLC station no. must be 2 in OMMS auto match mode.

Net type: OMMS: one HMI one device, one HMI multi-device (fig. 3-1), multi-HMI multi-device (fig. 3-2). Please choose it as the actual needs.

Baud rate: set the same baud rate for HMI and PLC.

Other settings please refer to the above HMI setting.

(7)click route:

(8)First read the settings, then click add item, set the parameters, then click write.

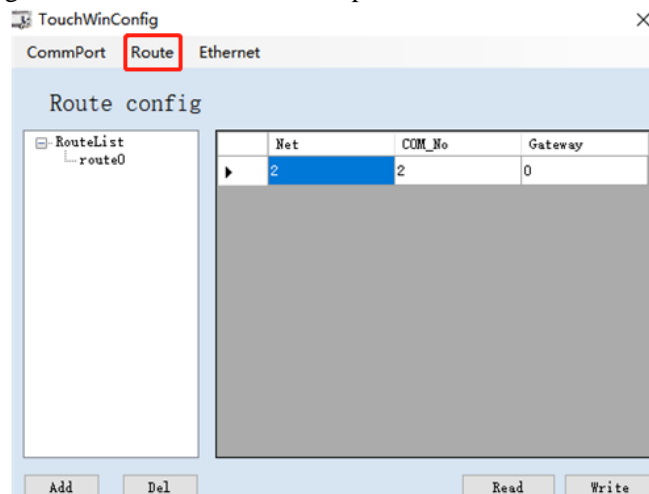

After finishing the configuration, restart the PLC to make the settings effective.

2.4.4 Cable making

Model	Hardware version	Communication type	PLC port cable making	Download port cable making
TG/TE		RS485	Fig 1	Fig 1
		RS232	Fig 3	
TG765-NT (TN765-ET)	V1.0	RS485	Fig 1	Fig 1
		RS232	\	Fig 3
	V1.1 and up	RS485	Fig 2	Fig 1
		RS232	\	Fig 3
TG865-NT (TN865-ET)	V1.0 and up	RS485	Fig 2	Fig 1
		RS232	\	Fig 3
TGA63-NT (TNA63-ET)	V1.0 and up	RS485	Fig 2	Fig 1
		RS232	\	Fig 3

2.4.4.1 Cable

1. TE/TG and TG765-NT (V1.0) (RS485 mode)

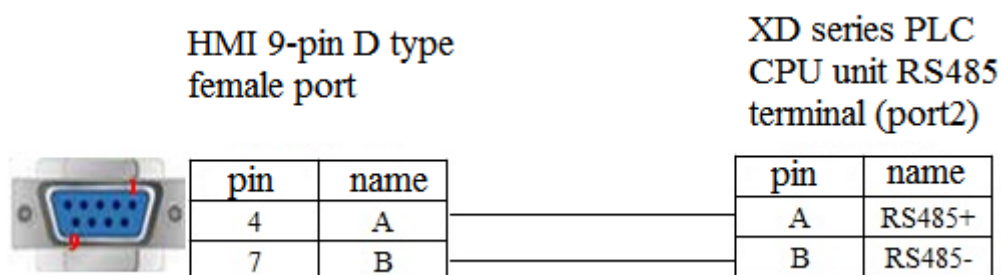

Fig 1

2. -NT model (V1.1) PLC port RS485 mode

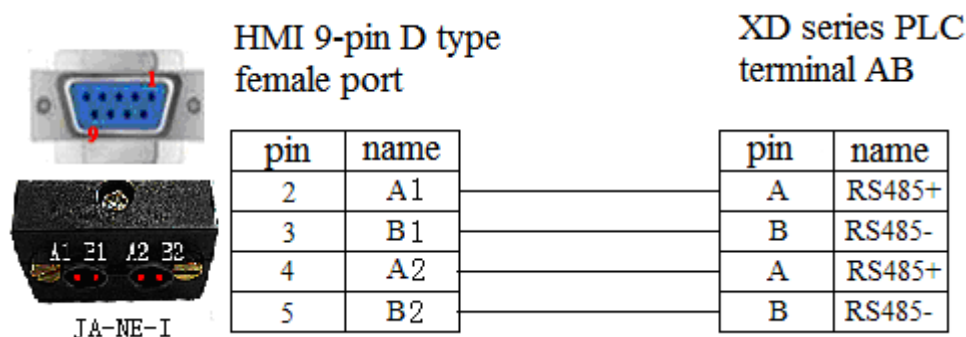

Fig 2

Note: use together with JA-NE-I, which is easy to wiring.

3. TE/TG (download port) series RS232 mode

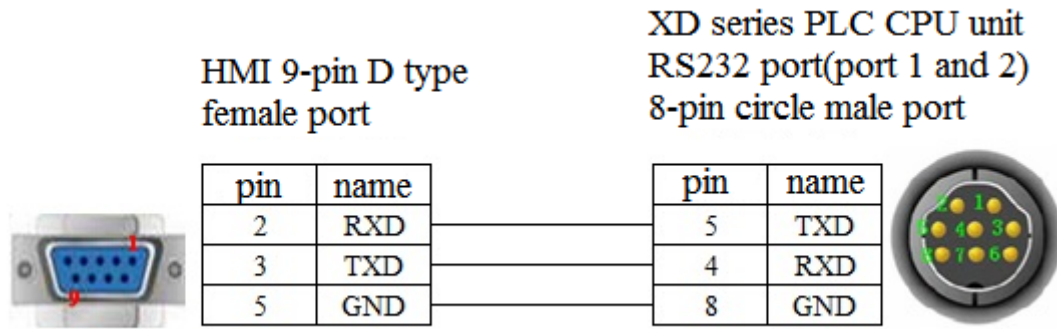
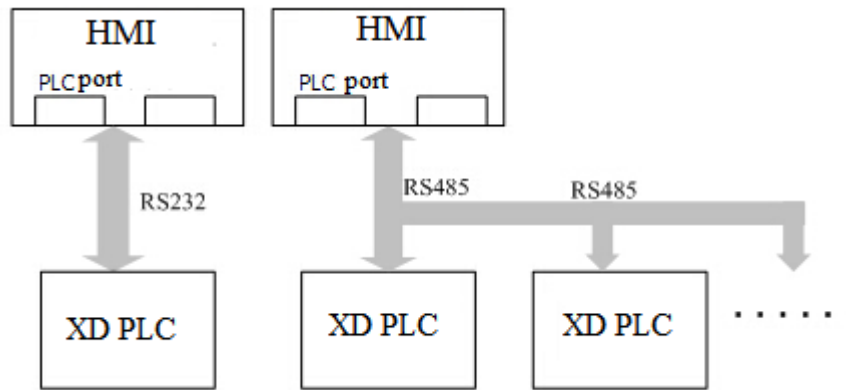
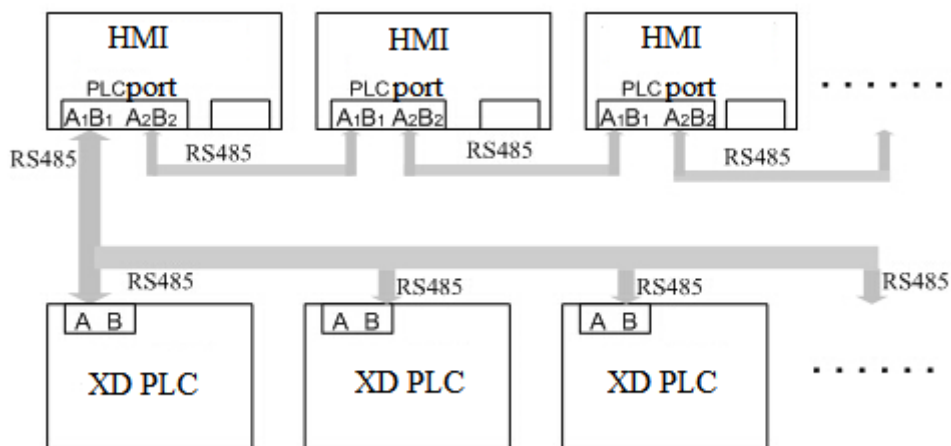

Fig 3

2.4.4.2 OMMS wiring mode (-NT model PLC port no RS232)



2.4.4.3 TBN wiring mode



2.4.5 Device address

PLC address	Range	Object type	Notes
X	0~77777777	Bit	Input relay
X1 xxxx	0~77777777	Bit	Extended module input relay
X2 xxxx	0~77777777	Bit	Extended BD input relay
X3XXXX	0~77	Bit	Extended ED input relay
Y	0~77777777	Bit	Output relay
Y1 xxxx	0~77777777	Bit	Extended module output relay
Y2 xxxx	0~77777777	Bit	Extended BD output relay
Y3XXXX	0~77	Bit	Extended ED output relay
M	0~99999999	Bit	Internal relay
S	0~99999999	Bit	Flow
SM	0~99999999	Bit	Internal relay, special using
T	0~99999999	Bit	Timer
C	0~99999999	Bit	Counter
ET	0~99999999	Bit	Timer, precise timer
SE	0~99999999	Bit	Sequence block wait instruction special coil
HM	0~99999999	Bit	Internal relay, power-off retentive
HS	0~99999999	Bit	Flow, power-off retentive
HT	0~99999999	Bit	Auxiliary relay, power-off retentive
HC	0~99999999	Bit	Counter, power-off retentive
HSC	0~99999999	Bit	Counter, high speed counter
D	0~99999999	Word/DWord	Data register
ID	0~99999999	Word/DWord	Analog input
ID1xxxx	0~99999999	Word/DWord	Extended module analog input
ID2xxxx	0~99999999	Word/DWord	Extended BD analog input
ID3XXXX	0~99	Word/DWord	Extended ED analog input
QD	0~99999999	Word/DWord	Analog output
QD1xxxx	0~99999999	Word/DWord	Extended module analog output
QD2xxxx	0~99999999	Word/DWord	Extended BD analog output
QD3XXXX	0~99	Word/DWord	Extended ED analog output
SD	0~99999999	Word/DWord	Data register, special using
TD	0~99999999	Word/DWord	Timer value
CD	0~99999999	Word/DWord	Counter value
ETD	0~99999999	Word/DWord	Timer value, precise timer
HD	0~99999999	Word/DWord	Data register
HSD	0~99999999	Word/DWord	Data register, power-off retentive
HTD	0~99999999	Word/DWord	Timer value, power-off retentive
HCD	0~99999999	Word/DWord	Counter value, power-off retentive
HSCD	0~99999999	Word/DWord	Counter value, high speed counter

PLC address	Range	Object type	Notes
FD	0~99999999	Word/DWord	FlashROM register
SFD	0~99999999	Word/DWord	FlashROM register, special using
FS	0~99999999	Word/DWord	Special security register
DM	0~99999999	Word	For data register
DX	0~77777777	Word	For data register
DX1xxxx	0~77777777	Word	For data register, extended module
DX2xxxx	0~77777777	Word	For data register, extended BD
DX3XXXX	0~77777777	Word	For data register, extended ED
DY	0~77777777	Word	For data register
DY1xxxx	0~77777777	Word	For data register, extended module
DY2xxxx	0~77777777	Word	For data register, extended BD
DY3XXXX	0~77777777	Word	For data register, extended ED
DS	0~99999999	Word	For data register
DSM	0~99999999	Word	For data register, special function using
DT	0~99999999	Word	For data register
DC	0~99999999	Word	For data register
DET	0~99999999	Word	For data register, precise timer
DSE	0~99999999	Word	For data register, WAIT instruction
DHM	0~99999999	Word	For data register, power-off retentive
DHS	0~99999999	Word	For data register, power-off retentive
DHT	0~99999999	Word	For data register, power-off retentive
DHC	0~99999999	Word	For data register, power-off retentive
DHSC	0~99999999	Word	For data register, high speed counter

2.5 Xinje V5 series inverter

2.5.1 Device type

Series	Connected module	Port	Cable	PLC model in Touchwin software
V5	CPU RS485 port	RS485	Fig 1	Xinje V5 series inverter

2.5.2 Parameters

HMI:

Parameters	Recommend settings	Choices of settings	Note
PLC type	Xinje V5 series inverter		
Port	RS485	RS485	
Data bit	8	7 or 8	
Stop bit	1	1 or 2	
Parity	Even parity	Even/odd/no parity	
Baud rate	19200	4800/38400/9600/115200/19200/187500	
Station no.	1	0~255	

Note: please set the communication wait time if the connection is error.

Communicate parameters

Baud Rate: 4800 56000 9600 57600 19200 115200 38400 187500

Data bit: 7位 8位

Stop bit: 1位 2位

Checksum: No parity Odd Even

Delay: ms

Send data Virtual Station

Word exchange Retry Tim

OK Cancel

Inverter:

Function code	Name	Range	Meaning
P0.01	Frequency setting channel	4	Serial port setting
P0.03	Run command channel	2	Run via serial port
P3.09	Communication settings	054	The unit:19200 Decade: 1-8-1, even parity Hundred: no definition

2.5.3 Cable making

RS485:

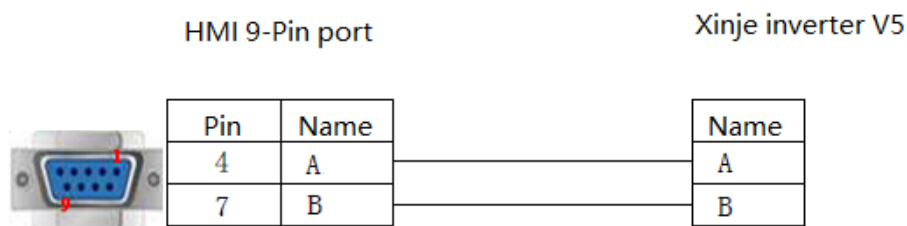

Fig 1

2.5.4 Device address

PLC address	Range	Modbus address (hex)	Object type	Explanation
Forward/stop	0	2000	Bit(only write)	
Reverse/stop	0	2000	Bit(only write)	
Jog forward command/stop	0	2000	Bit(only write)	
Jog reverse/stop	0	2000	Bit(only write)	
Emergency stop	0	2000	Bit(only write)	Write 08H
Fault reset	0	2000	Bit(only write)	Write 0AH
Running state	0	2101.0	Bit(only read)	
Forward/reverse sign	0	2101.2	Bit(only read)	
Under-voltage state	0	2101.1	Bit(only read)	
Alarm code	0	2100	Word(only read)	
Read setting frequency	0	2102	Word	
Set frequency via serial port	0	2001	Word(only write)	
Output frequency	0	2103	Word	
Output current	0	2104	Word	
Output voltage	0	2106	Word	
Parameters	0~FFFF	0000~0FFF	Word	GGmmH,GG:Group No. of function code mm:function code No. For example,the modbus address of function code

				P2.11 is 020BH.
Bus voltage	0	2105	Word	
Motor speed	0	2107	Word	
Module temperature	0	2108	Word	
VI analog input	0	2109	Word	
CI analog input	0	210A	Word	

2.6 XINJE XD/XG (Ethernet) series PLC

2.6.1 Device type

Series	CPU	Connected module	Port	Cable making	PLC model in Touchwin software
XD XG	XD5E XDE XGE	CPU direct connection	RJ45	Fig 1 or Fig 2	Xinje series XD/XG
		Communication module T-BOX			

2.6.2 Parameters

Taking XDE series PLC as an example, this paper explains the communication setting of Xinje XD/XG series protocol.

PLC settings

There are two methods to configure PLC Ethernet parameters: direct configuration through PLC software and configuration using config tool. The two configurations are interrelated. Just use one of them..

Method 1: connect the PLC to the computer, open the PLC programming software, open the PLC configuration in the engineering column on the left side of the software, double-click the “Ethernet port” below, manually set the Ethernet parameters of PLC in the pop-up configuration window, and click “write to PLC” after setting:

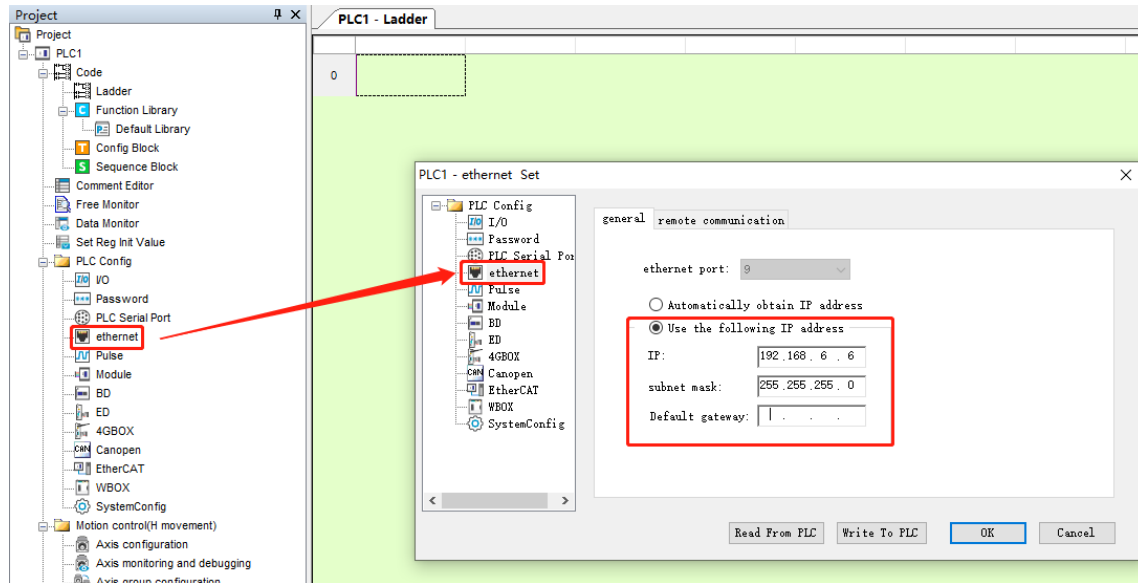

Note: After the parameter is written, the PLC needs to be restarted to take effect.

Method 2: Connect the PLC to the computer, first connect the PLC with the config tool, open the config

tool, then click PLC - find device- XNET:

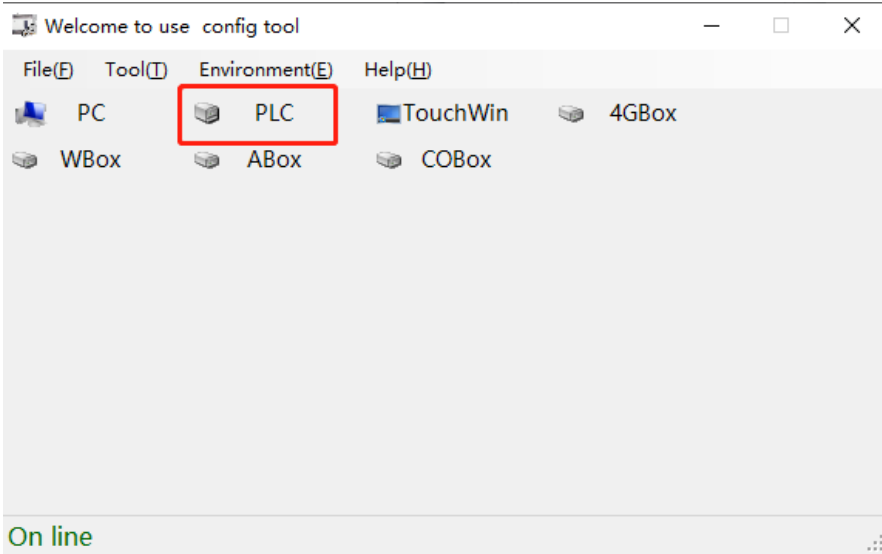

Set the port number of the computer in the pop-up window (you can view it in computer device manager - port)

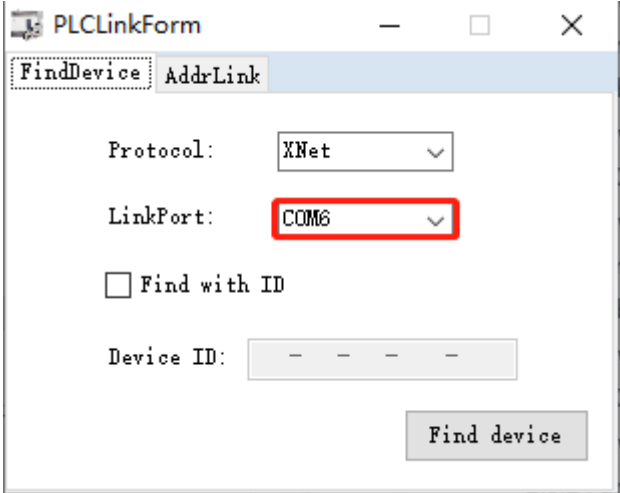

After the PLC is successfully connected, click Ethernet:
Set the Ethernet parameters (IP address, mask and gate) of PLC in the pop-up window. The Ethernet port here defaults 9 and should not be modified. Click "write" after setting.

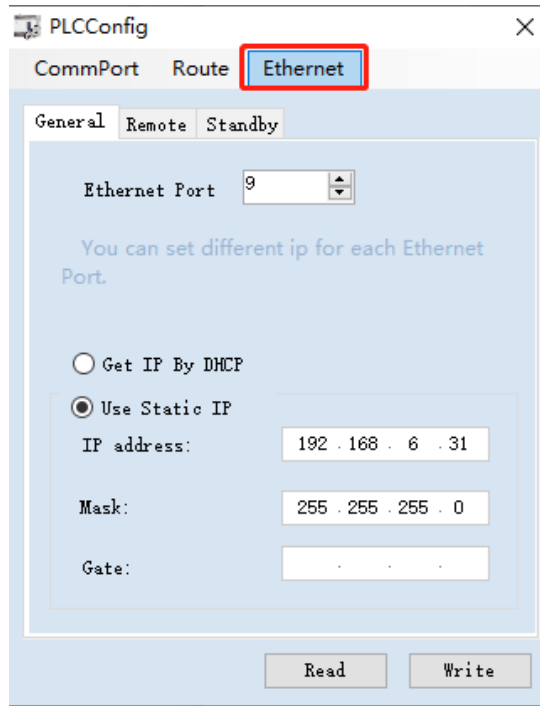

Note: After the parameter is written, the PLC needs to be restarted to take effect.

HMI settings:

After selecting the human-machine interface model as TG(-ET), click next, and select “Net device” in the device list. In Local IP address: the IP address ,as long as it does not conflict with other IP address in the network. In this example, the IP of PLC is 192.168.6.6, and it can be set to 192.168.6.10.

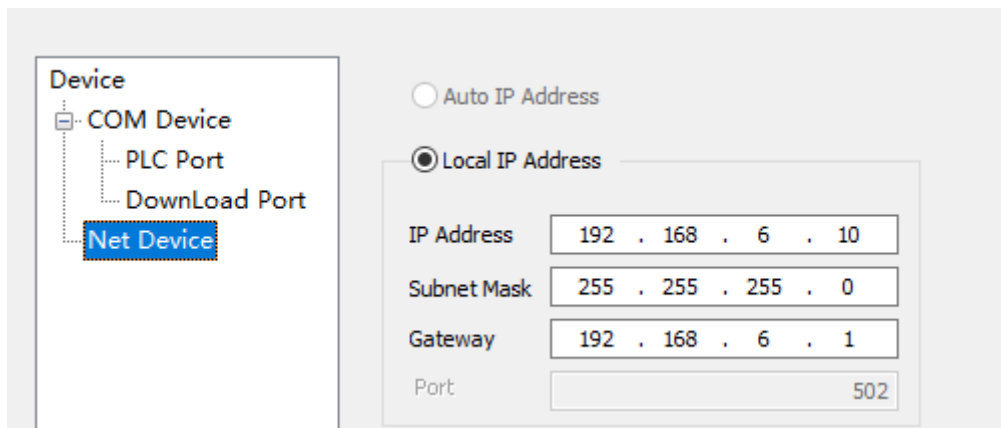

Right click net device, build a new Ethernet device.

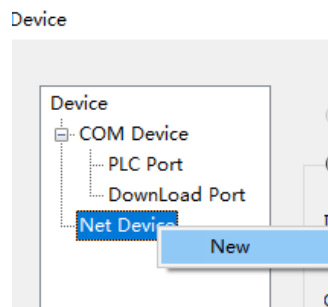

Select “Xinje XD/XG series” in the equipment list. This IP address is the IP address of Xinje PLC, and the

port number is 502 by default. It cannot be modified:

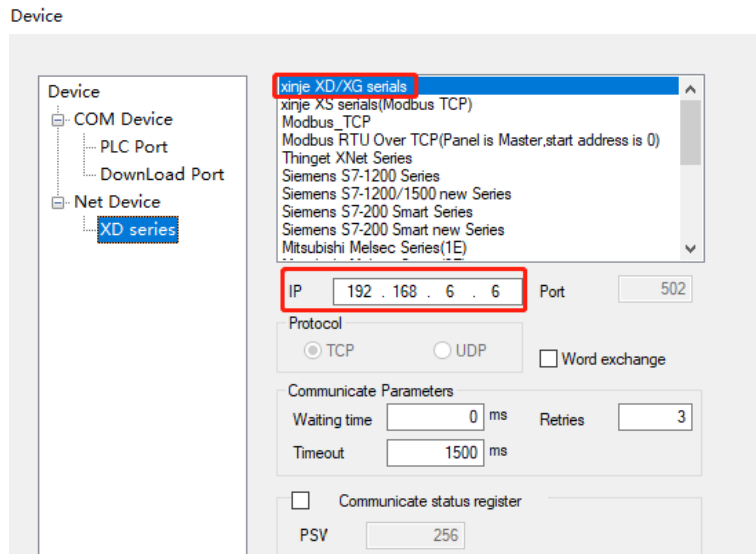

For the setting of communication parameters, the communication status can be output by default: check “output communication status”, set PSW to 256, and select PSW256 ~ PSW259 as the number of communication successes, communication failures, communication timeouts and communication errors respectively. The output communication status address can be set by customers.

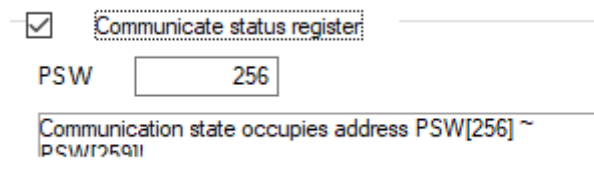

After setting, click “next” to end the setting and enter the screen editing interface. Place data input part on the screen and select the corresponding equipment “XD series” in the equipment drop-down bar:

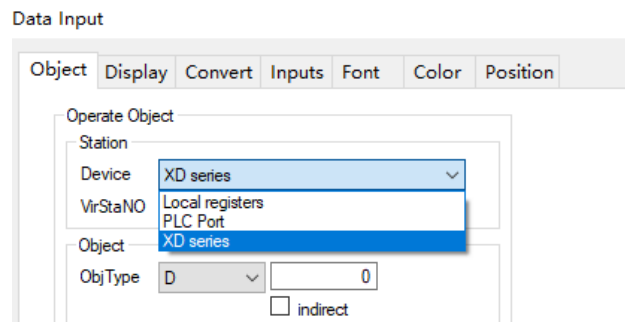

2.6.3 Cable making

RJ45 straight through cable (connected to hub) or RJ45 crossover cable:

pin	colour		pin	colour
1	white orange		1	white orange
2	orange		2	orange
3	white green		3	white green
4	blue		4	blue
5	white blue		5	white blue
6	green		6	green
7	white brown		7	white brown
8	brown		8	brown

Fig 1

2.6.4 Device address

PLC address	Range	Object type	Notes
X	0~77777777	Bit	Input relay
X1 xxxx	0~77777777	Bit	Extended module input relay
X2 xxxx	0~77777777	Bit	Extended BD input relay
X3XXXX	0~77	Bit	Extended ED input relay
Y	0~77777777	Bit	Output relay
Y1 xxxx	0~77777777	Bit	Extended module output relay
Y2 xxxx	0~77777777	Bit	Extended BD output relay
Y3XXXX	0~77	Bit	Extended ED output relay
M	0~99999999	Bit	Internal relay
S	0~99999999	Bit	Flow
SM	0~99999999	Bit	Internal relay, special using
T	0~99999999	Bit	Timer
C	0~99999999	Bit	Counter
ET	0~99999999	Bit	Timer, precise timer
SE	0~99999999	Bit	Sequence block wait instruction special coil
HM	0~99999999	Bit	Internal relay, power-off retentive
HS	0~99999999	Bit	Flow, power-off retentive
HT	0~99999999	Bit	Auxiliary relay, power-off retentive
HC	0~99999999	Bit	Counter, power-off retentive
HSC	0~99999999	Bit	Counter, high speed counter
D	0~99999999	Word/DWord	Data register
ID	0~99999999	Word/DWord	Analog input
ID1xxxx	0~99999999	Word/DWord	Extended module analog input
ID2xxxx	0~99999999	Word/DWord	Extended BD analog input
ID3XXXX	0~99	Word/DWord	Extended ED analog input
QD	0~99999999	Word/DWord	Analog output
QD1xxxx	0~99999999	Word/DWord	Extended module analog output
QD2xxxx	0~99999999	Word/DWord	Extended BD analog output

PLC address	Range	Object type	Notes
QD3XXXX	0~99	Word/DWord	Extended ED analog output
SD	0~99999999	Word/DWord	Data register, special using
TD	0~99999999	Word/DWord	Timer value
CD	0~99999999	Word/DWord	Counter value
ETD	0~99999999	Word/DWord	Timer value, precise timer
HD	0~99999999	Word/DWord	Data register
HSD	0~99999999	Word/DWord	Data register, power-off retentive
HTD	0~99999999	Word/DWord	Timer value, power-off retentive
HCD	0~99999999	Word/DWord	Counter value, power-off retentive
HSCD	0~99999999	Word/DWord	Counter value, high speed counter
FD	0~99999999	Word/DWord	FlashROM register
SFD	0~99999999	Word/DWord	FlashROM register, special using
FS	0~99999999	Word/DWord	Special security register
DM	0~99999999	Word	For data register
DX	0~77777777	Word	For data register
DX1xxxx	0~77777777	Word	For data register, extended module
DX2xxxx	0~77777777	Word	For data register, extended BD
DX3XXXX	0~77777777	Word	For data register, extended ED
DY	0~77777777	Word	For data register
DY1xxxx	0~77777777	Word	For data register, extended module
DY2xxxx	0~77777777	Word	For data register, extended BD
DY3XXXX	0~77777777	Word	For data register, extended ED
DS	0~99999999	Word	For data register
DSM	0~99999999	Word	For data register, special function using
DT	0~99999999	Word	For data register
DC	0~99999999	Word	For data register
DET	0~99999999	Word	For data register, precise timer
DSE	0~99999999	Word	For data register, WAIT instruction
DHM	0~99999999	Word	For data register, power-off retentive
DHS	0~99999999	Word	For data register, power-off retentive
DHT	0~99999999	Word	For data register, power-off retentive
DHC	0~99999999	Word	For data register, power-off retentive
DHSC	0~99999999	Word	For data register, high speed counter

2.7 XINJE X-NET(Ethernet) series PLC

The configuration and use of Xinje XNET protocol are the same as that of Xinje XD / XG protocol. The PLC configuration under the two kinds of communication is exactly the same, and different protocols need to be selected on the touch screen. The difference between the two protocols lies in the different address range. Part of XD / XG series PLC has a large address range, while only a few are used for Modbus communication. If all addresses can be accessed, xnet protocol needs to be used.

2.7.1 Device type

Series	CPU	Connected module	Port	Cable making	PLC model in Touchwin software
XD XG	XD5E XDE XGE	CPU direct connection	RJ45	Fig 1 or Fig 2	Xinje series XD/XG
		Communication module T-BOX			

2.7.2 Parameters

Taking XDE series PLC as an example, this paper explains the communication settings of Xinje XNET series protocol equipment.

PLC settings

Method 1: connect the PLC to the computer, open the PLC programming software, open the PLC Config in the engineering column on the left side of the software, double-click the “Ethernet port” below, manually set the Ethernet parameters of PLC in the pop-up configuration window, and click “write to PLC” after setting:

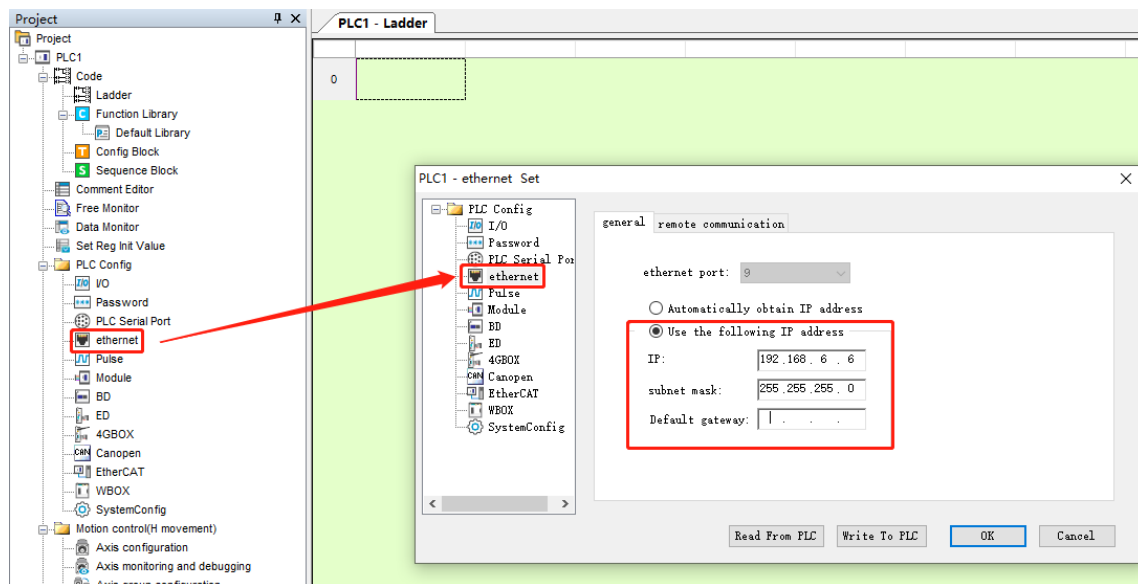

Note: After the parameter is written, the PLC needs to be restarted to take effect.

Method 2:

Connect the PLC to the computer, first connect the PLC with the config tool, open the config tool, then click PLC - find device- XNET:

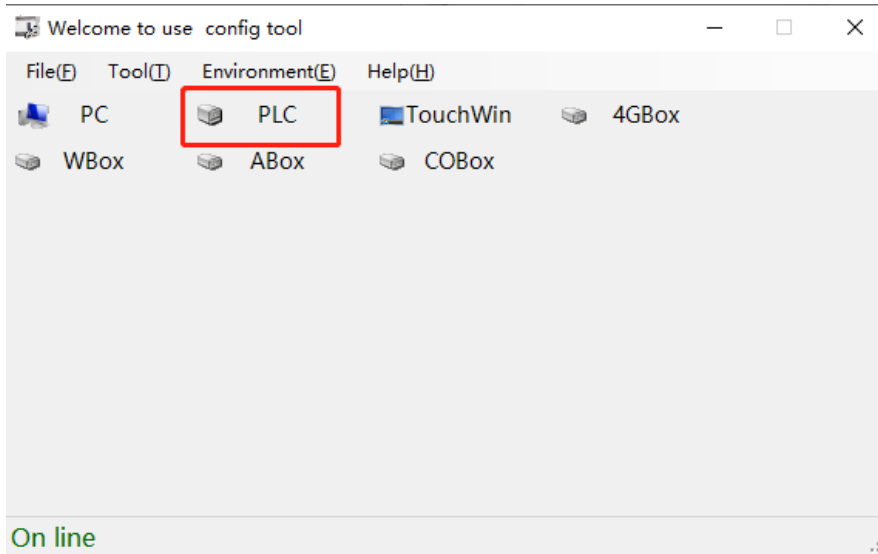

Set the port number of the computer in the pop-up window (you can view it in computer device manager - port)

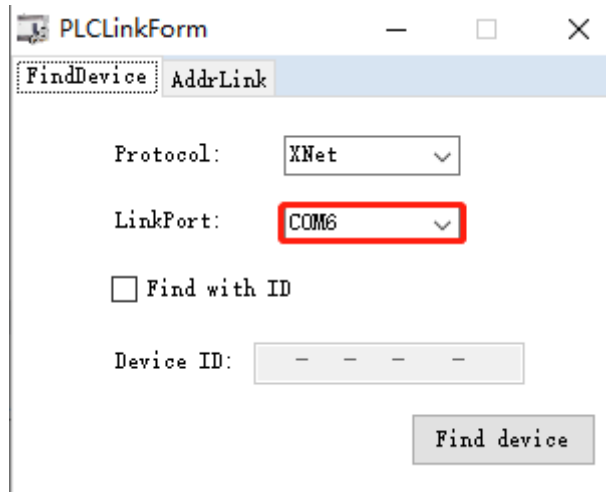

After the PLC is successfully connected, click Ethernet:

Set the Ethernet parameters (IP address, mask and gate) of PLC in the pop-up window. The Ethernet port here defaults 9 and should not be modified. Click “write” after setting.

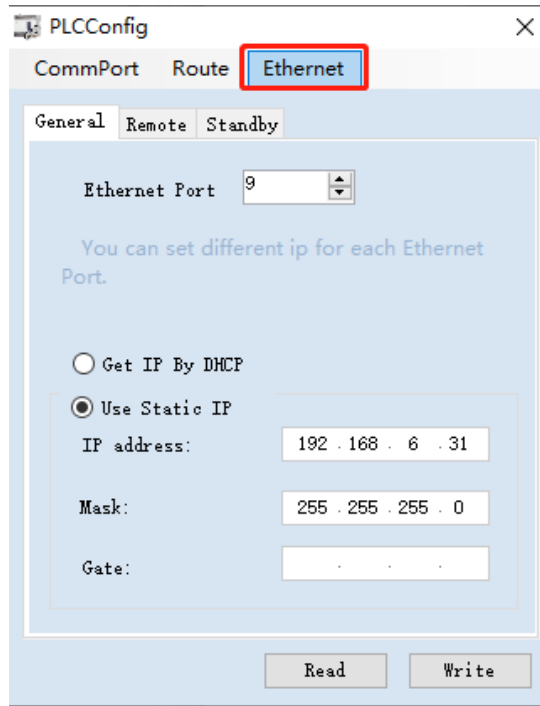

Note: After the parameter is written, the PLC needs to be restarted to take effect.

If the communication fails, check whether the routing table configuration is correct. Click read:

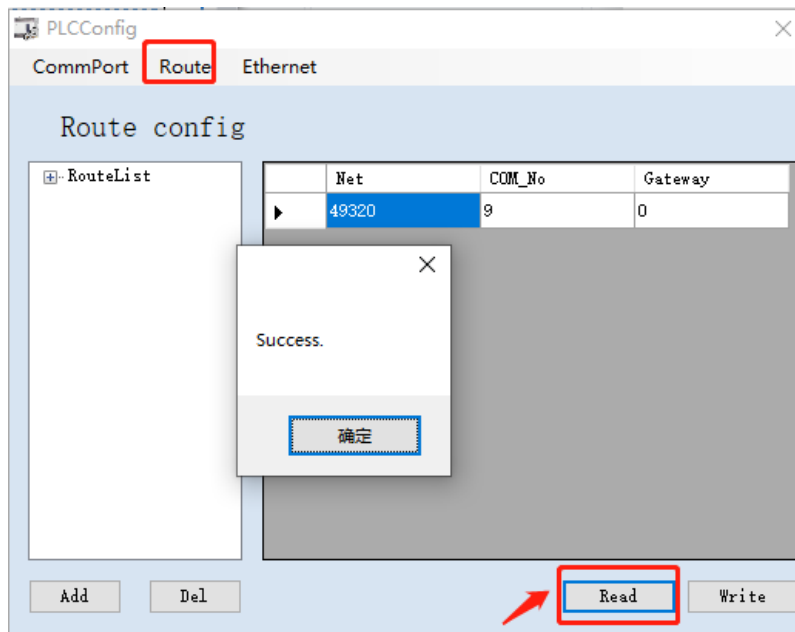

Note: if the IP address used is A.B.C.D. Net column data is $A * 256 + B$.

HMI settings

After selecting the human-machine interface model as TG(-ET), click next, and select "Net device" in the device list. In Local IP address: the IP address ,as long as it does not conflict with other IP address in the network. In this example, the IP of PLC is 192.168.6.6, and it can be set to 192.168.6.10.

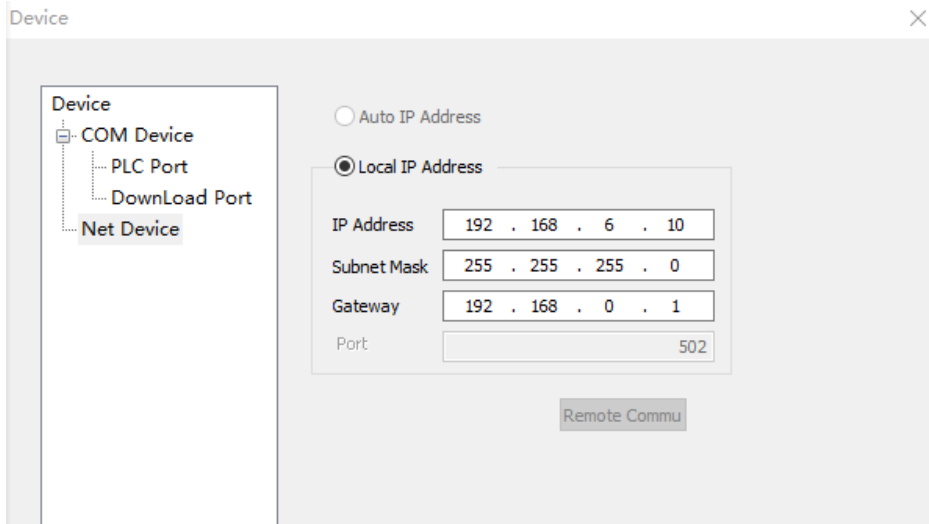

Right click net device, build a new Ethernet device.

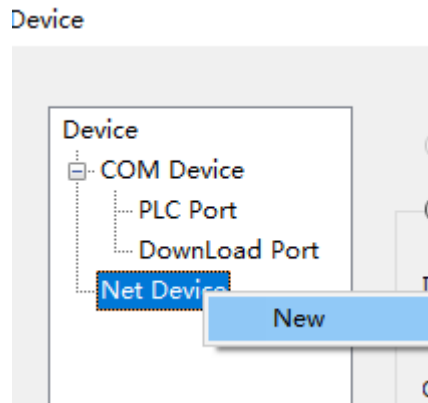

Select “Xinje xnet series” in the equipment list. This IP address is the IP address of Xinje PLC, and the port number is 502 by default. It cannot be modified:

System Settings

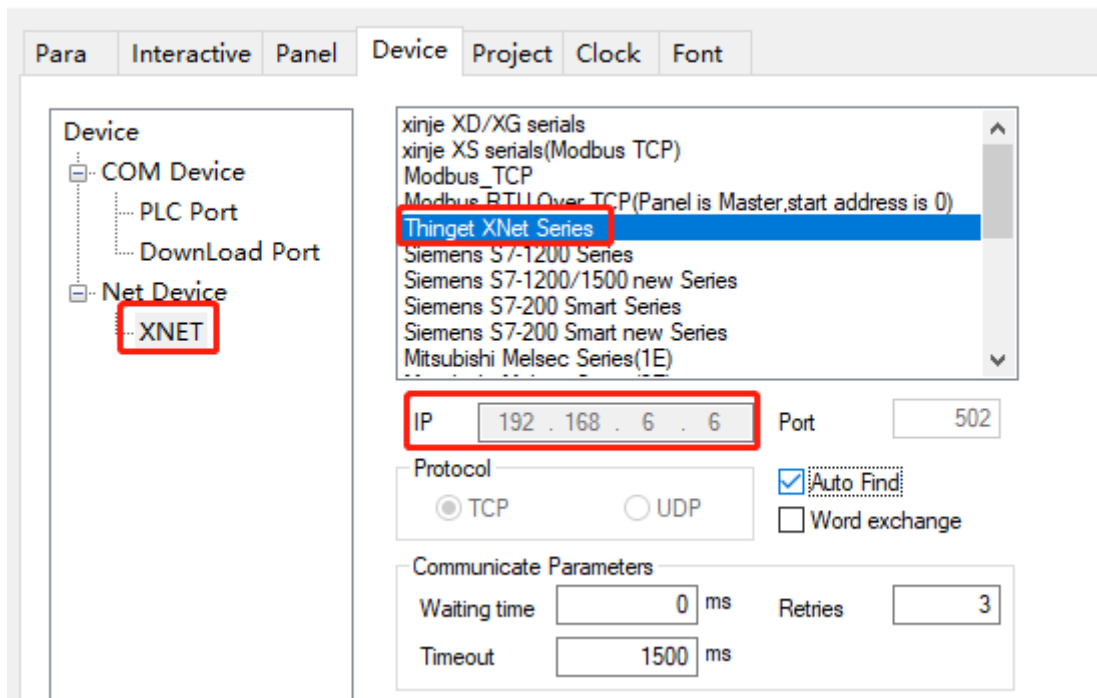

For the setting of communication parameters, the communication status can be output by default: check

“output communication status”, set PSW to 256, and select PSW256 ~ PSW259 as the number of communication successes, communication failures, communication timeouts and communication errors respectively. The output communication status address can be set by customers.

Communicate status register:

PSW

Communication state occupies address PSW[256] ~ PSW[259]

After setting, click “next” to end the setting and enter the screen editing interface. Place data input part on the screen and select the corresponding equipment “XD series” in the equipment drop-down bar:

Data Input

Object Display Convert Inputs Font Color Position

Operate Object

Station

Device

Net ID

Object

ObjType

indirect

2.7.3 Cable making

RJ45 straight through cable (connected to hub) or RJ45 crossover cable:

pin	colour		pin	colour
1	white orange	—————	1	white orange
2	orange	—————	2	orange
3	white green	—————	3	white green
4	blue	—————	4	blue
5	white blue	—————	5	white blue
6	green	—————	6	green
7	white brown	—————	7	white brown
8	brown	—————	8	brown

Fig 1

pin	colour		pin	colour
1	white orange		1	white green
2	orange		2	green
3	white green		3	white orange
4	blue		4	blue
5	white blue		5	white blue
6	green		6	orange
7	white brown		7	white brown
8	brown		8	brown

Fig 2

2.7.4 Device address

PLC address	Range	Object type	Notes
X	0~77777777	Bit	Input relay
X1 xxxx	0~77777777	Bit	Extended module input relay
X2 xxxx	0~77777777	Bit	Extended BD input relay
X3XXXX	0~77	Bit	Extended ED input relay
Y	0~77777777	Bit	Output relay
Y1 xxxx	0~77777777	Bit	Extended module output relay
Y2 xxxx	0~77777777	Bit	Extended BD output relay
Y3XXXX	0~77	Bit	Extended ED output relay
M	0~99999999	Bit	Internal relay
S	0~99999999	Bit	Flow
SM	0~99999999	Bit	Internal relay, special using
T	0~99999999	Bit	Timer
C	0~99999999	Bit	Counter
ET	0~99999999	Bit	Timer, precise timer
SE	0~99999999	Bit	Sequence block wait instruction special coil
HM	0~99999999	Bit	Internal relay, power-off retentive
HS	0~99999999	Bit	Flow, power-off retentive
HT	0~99999999	Bit	Auxiliary relay, power-off retentive
HC	0~99999999	Bit	Counter, power-off retentive
HSC	0~99999999	Bit	Counter, high speed counter
D	0~99999999	Word/DWord	Data register
ID	0~99999999	Word/DWord	Analog input
ID1xxxx	0~99999999	Word/DWord	Extended module analog input
ID2xxxx	0~99999999	Word/DWord	Extended BD analog input
ID3XXXX	0~99	Word/DWord	Extended ED analog input
QD	0~99999999	Word/DWord	Analog output
QD1xxxx	0~99999999	Word/DWord	Extended module analog output
QD2xxxx	0~99999999	Word/DWord	Extended BD analog output

PLC address	Range	Object type	Notes
QD3XXXX	0~99	Word/DWord	Extended ED analog output
SD	0~99999999	Word/DWord	Data register, special using
TD	0~99999999	Word/DWord	Timer value
CD	0~99999999	Word/DWord	Counter value
ETD	0~99999999	Word/DWord	Timer value, precise timer
HD	0~99999999	Word/DWord	Data register
HSD	0~99999999	Word/DWord	Data register, power-off retentive
HTD	0~99999999	Word/DWord	Timer value, power-off retentive
HCD	0~99999999	Word/DWord	Counter value, power-off retentive
HSCD	0~99999999	Word/DWord	Counter value, high speed counter
FD	0~99999999	Word/DWord	FlashROM register
SFD	0~99999999	Word/DWord	FlashROM register, special using
FS	0~99999999	Word/DWord	Special security register
DM	0~99999999	Word	For data register
DX	0~77777777	Word	For data register
DX1xxxx	0~77777777	Word	For data register, extended module
DX2xxxx	0~77777777	Word	For data register, extended BD
DX3XXXX	0~77777777	Word	For data register, extended ED
DY	0~77777777	Word	For data register
DY1xxxx	0~77777777	Word	For data register, extended module
DY2xxxx	0~77777777	Word	For data register, extended BD
DY3XXXX	0~77777777	Word	For data register, extended ED
DS	0~99999999	Word	For data register
DSM	0~99999999	Word	For data register, special function using
DT	0~99999999	Word	For data register
DC	0~99999999	Word	For data register
DET	0~99999999	Word	For data register, precise timer
DSE	0~99999999	Word	For data register, WAIT instruction
DHM	0~99999999	Word	For data register, power-off retentive
DHS	0~99999999	Word	For data register, power-off retentive
DHT	0~99999999	Word	For data register, power-off retentive
DHC	0~99999999	Word	For data register, power-off retentive
DHSC	0~99999999	Word	For data register, high speed counter

2.8 ABB PLC

2.8.1 Device type

ABB PLC can communicate with Touchwin HMI by Modbus protocol.

Series	Port	Cable	PLC model in Touchwin software
AC500	PM564-T-ETH	Fig 1	ABB (AC500) Series

2.8.2 Parameters

HMI:

Parameters	Recommend settings	Choices of settings	Note
PLC type	ABB AC500		
Port	RS485	RS485	
Data bit	8	7 or 8	
Stop bit	1	1 or 2	
Parity	No parity	Even/odd/no parity	
Baud rate	19200	4800/38400/9600/115200/19200/187500	
Station no.	1	0~255	

PLC settings:

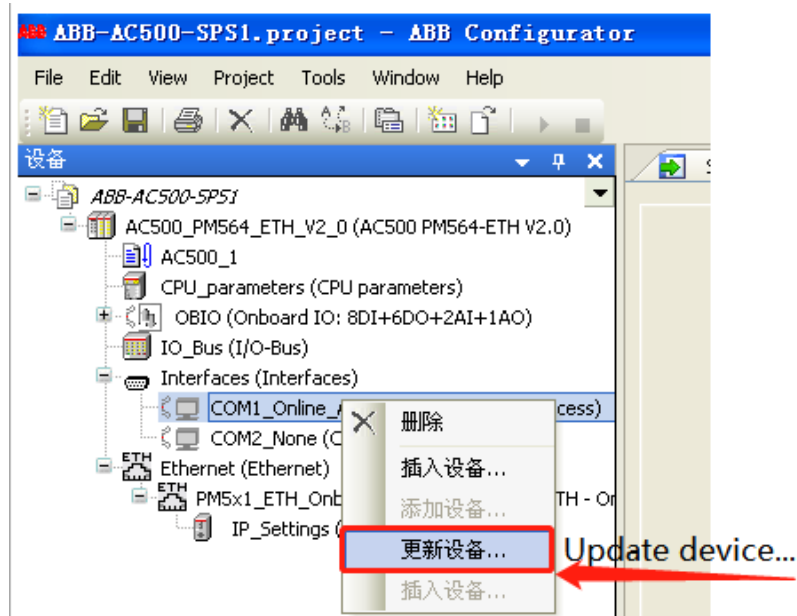

1. Choose Modbus in ABB AC500 PLC serial port:

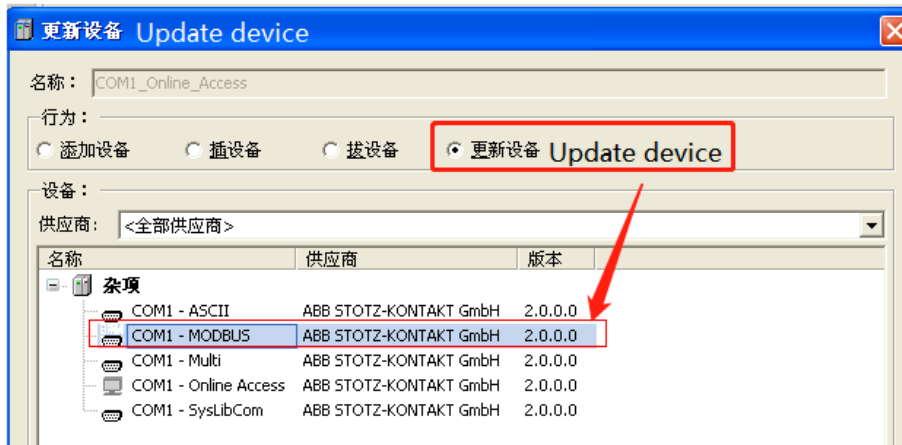

2. Choose COM1 MODBUS, then set the operation mode to slave. Other parameters should be the same to HMI.

COM1 - MODBUS 配置 Modbus设置

参数	类型	值	缺省值	单位
Enable login	Enumeration of BYTE	Disabled	Disabled	
RTS control	Enumeration of BYTE	Telegram	None	
Telegram ending value	WORD(0..65535)	3	3	
Baudrate	Enumeration of DWORD	19200	19200	bits/s
Parity	Enumeration of BYTE	even	even	
Data bits	Enumeration of BYTE	8	8	bits/character
Stop bits	Enumeration of BYTE	1	1	
Run on config fault	Enumeration of BYTE	No	No	
Operation mode	Enumeration of BYTE	Slave	None	
Address	BYTE(0..255)	1	0	

2.8.3 Cable making

ABB COM1 (RS-485):

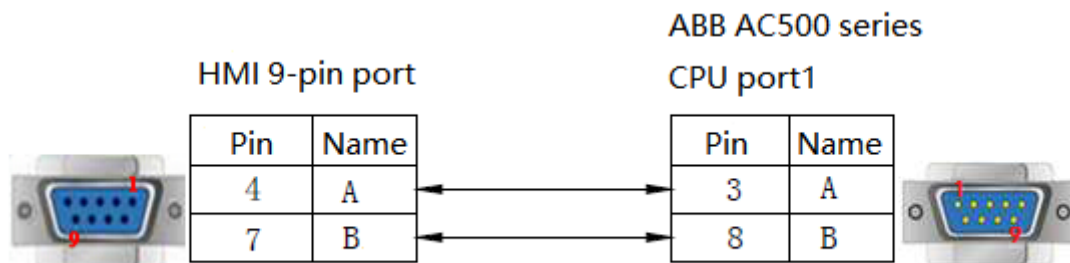

Fig 1

2.8.4 Device address

PLC address	Range	Data type	Explanation
MX0	0.0.0~0.65535.7	Bit	External I/O/internal coil
MX1	0.0.0~0.65535.7	Bit	External I/O/internal coil
MW0	0~32767	Word//DWord	Data register
MW1	0~32767	Word//DWord	Data register
MD0	0~32767	Word//DWord	Data register
MD1	0~32767	Word//DWord	Data register

2.9 Allen-Bradley series PLC

2.9.1 Device type

Series	CPU	Connected module	Port	Cable	PLC model in Touchwin software
Micrologix	Micrologix1000 Micrologix1200 Micrologix1500 (1762-L40BWA) (1764-LSP,1764-LRP)	CPU RS232	RS232	Fig 1	AB Mircrologix, SLC series (DF1 Full duplex protocol)
	Micrologix1400 (1766-L32BWAA)				
	Micrologix1500 (1764-LRP)				
SLC 500	SLC5/03 SLC5/04 SLC5/05	CPU RS232	RS232	Fig 2	
Mcicro830	2080-LC30	CPU RS232	RS232	Fig 1	Modbus RTU (panel is master)

2.9.2 Parameters

HMI:

Parameters	Recommend settings	Choices of settings	Note
PLC type	AB Mircrologix, SLC series (DF1 full-duplex)	AB Mircrologix, SLC series (DF1 full-duplex)/Modbus RTU(panel is master)	
Port	RS232	RS232	
Data bit	8		
Stop bit	1		
Parity	No parity		
Baud rate	9600	9600/19200/38400	
Station no.	1	0~255	

The default parameters of AB Mircrologix SLC series (DF1 full-duplex): 9600, 8, 1, no parity, station no.0.

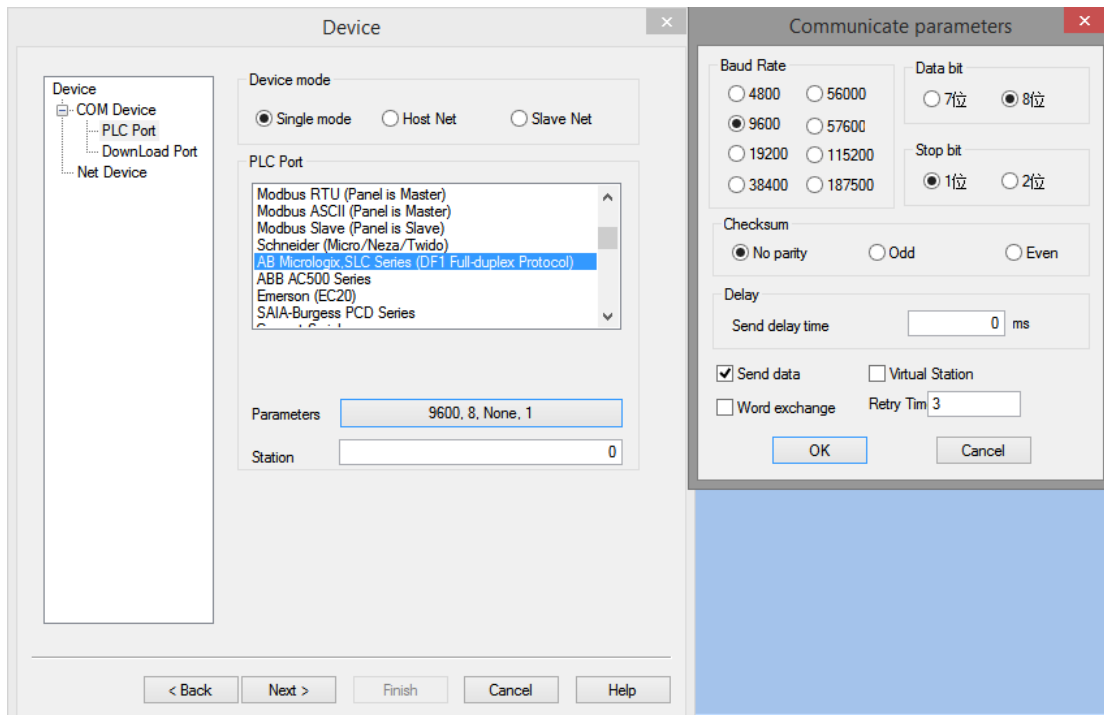

PLC setting:

Condition A: in touchwin software, the PLC protocol is AB Mircrologix, SLC series:

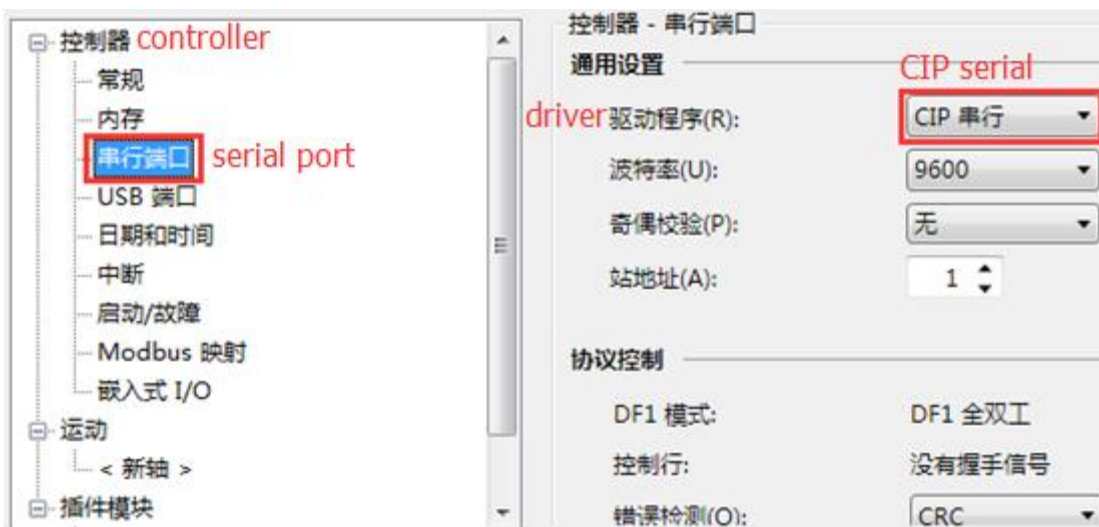

Condition B: in touchwin software, the PLC protocol is Modbus RTU (panel is master):



Note: for Modbus RTU communication, the address must set the mapping, PLC address 1 corresponds to Modbus address 0, PLC address 2 corresponds to Modbus address 1...

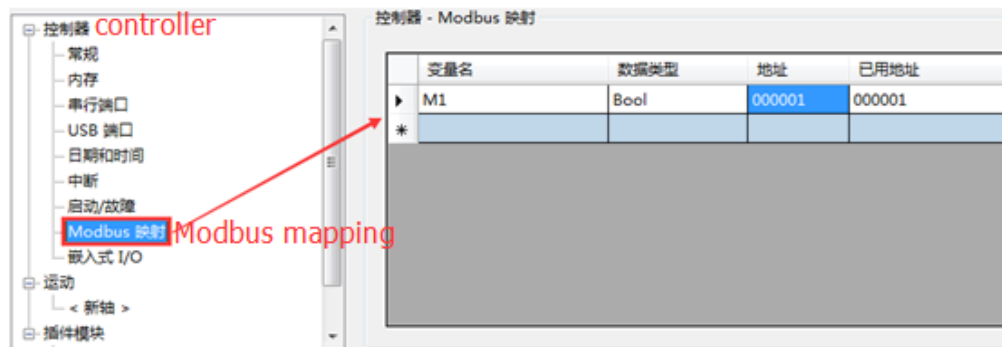

2.9.3 Cable making

(a) AB Micrologix series RS232:

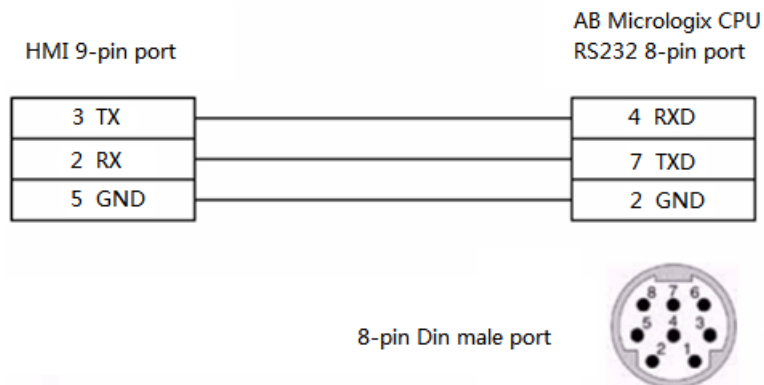

Fig1

(b) SLC500 RJ8 modular plug:

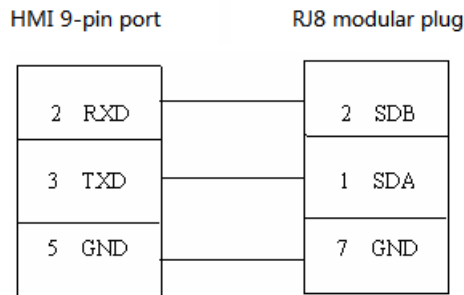

Fig2

2.9.4 Device address

Device address type	Range	Object type	Explanation
T4DN	0~999	Bit	Timer
C5DN	0~999	Bit	Counter
O	0.00~999.15	Bit	Output
I	0.00~999.15	Bit	Input
S	0.00~999.15	Bit	
B3	0.00~999.15	Bit	
R6	0.00~999.15	Bit	
N7	0.00~999.15	Bit	
O	0~999	Word	Used as register
I	0~999	Word	Used as register
S	0~999	Word	Used as register
B3	0~999	Word	Used as register
T4PRE	0~999	Word	Timer preset value
T4ACC	0~999	Word	Timer actual value
C5PRE	0~999	Word	Counter preset value
C5ACC	0~999	Word	Counter preset value
R6	0~999	Word	Data register
N7	0~999	Word/Dword	Data register
F8	0~999	Dword	Floating number register
R6LEN	0~999	Word	
P6POS	0~999	Word	

2.10 Bosch Rexroth series PLC

2.10.1 Device type

Bosch Rexroth IndraControl L series PLC can communicate with Xinje HMI via COM0 and COM1.

CPU	Connected module	Port	Cable	PLC model in Touchwin software
L20 L40	Direct connect to CPU	RS232	Fig 1	Bosch Rexroth IndraControl L40 Series PLC

2.10.2 Parameters

HMI:

Parameters	Recommend settings	Choices of settings	Note
PLC type	IndraControl L40 series PLC		
Port	RS232	RS232	
Data bit	8	7 or 8	
Stop bit	1	1 or 2	
Parity	No parity	Even/odd/no parity	
Baud rate	38400	4800/38400/9600/115200 /19200/187500	
Station no.	2	0~255	

The default parameters of **IndraControl L40** series PLC: 38400, 8, 1, no parity, station no.2

Note: To communicate with the touch screen, you need to declare the corresponding variables in Rexroth software first.

PLC settings

(1) L40 hardware connection



power supply terminal

- 1.1 and 2.1 short circuit
- 1.2 connect to +24V
- 1.3 connect to -24V

Inline I/O

**Extension with Rexroth-
Inline-Modules
max.64 Modules
max.32Byte I and O**

(2) L40 software setting

The Rexroth software indralogic on PC communicates with Rexroth indracontrol L40 through network port (IP of PLC during test: 192.168.100.103), open Rexroth software indralogic and create a new project:

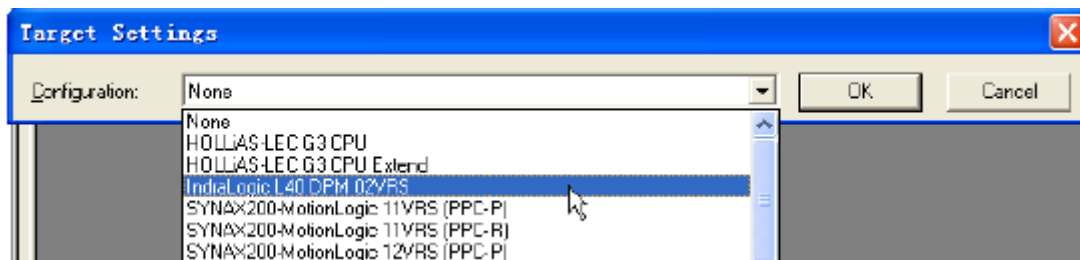

Click OK, as shown in the figure below

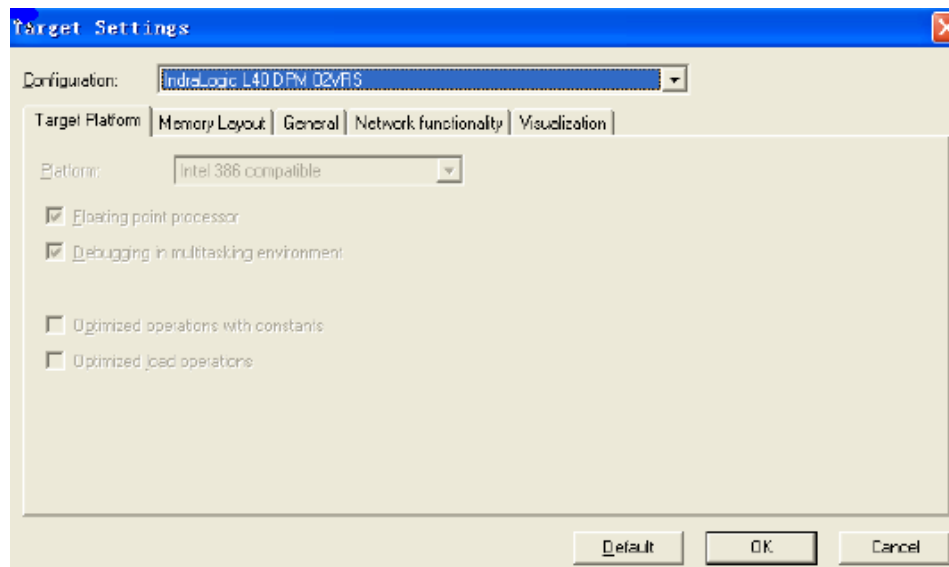

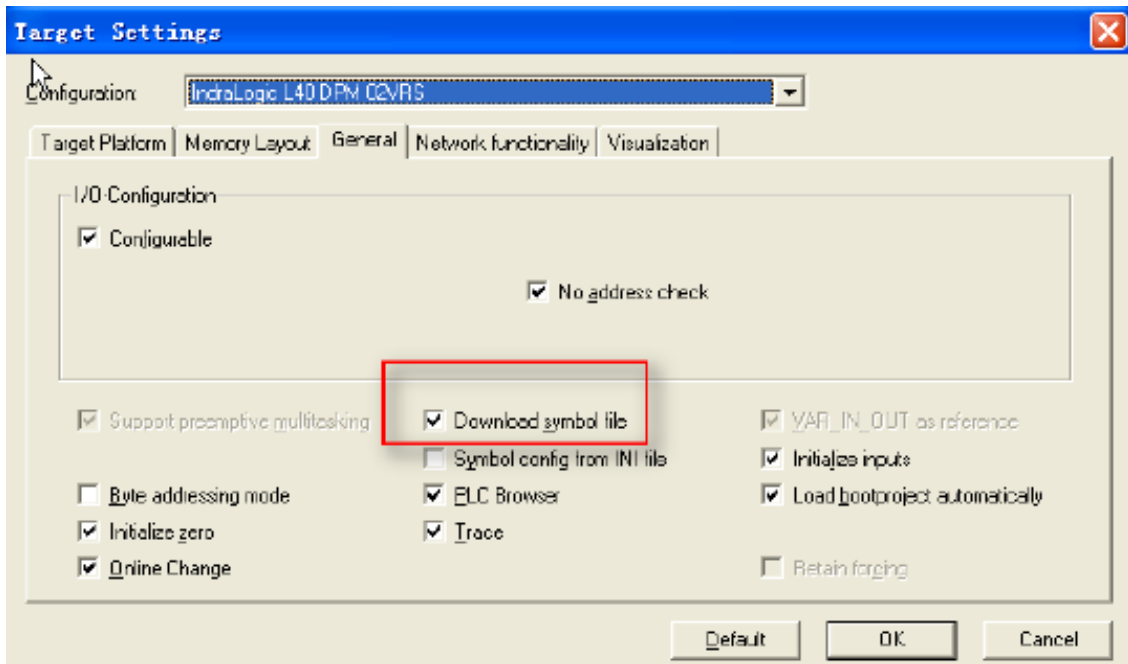

Click OK, as shown in the figure below.

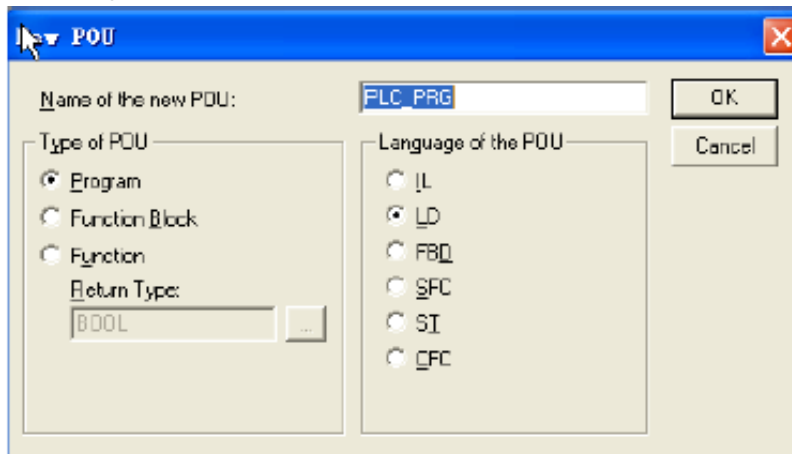

Build program :

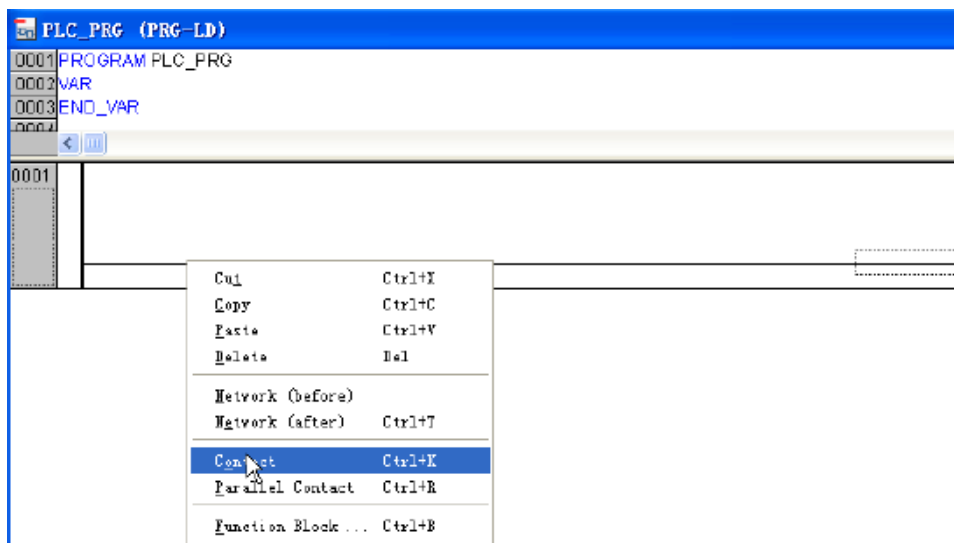

After inputting B0, a dialog box will pop up. The settings are as follows, and click OK:

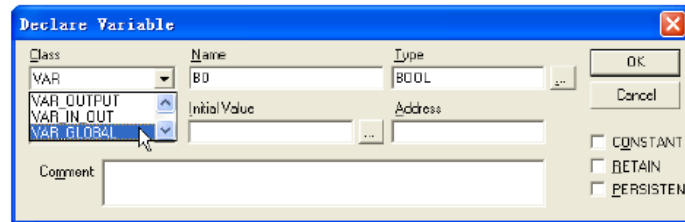

Build a coil:

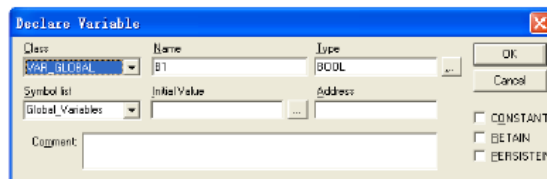
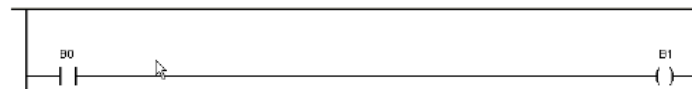

At the same time, you will find that two variables are automatically generated on the global variables:

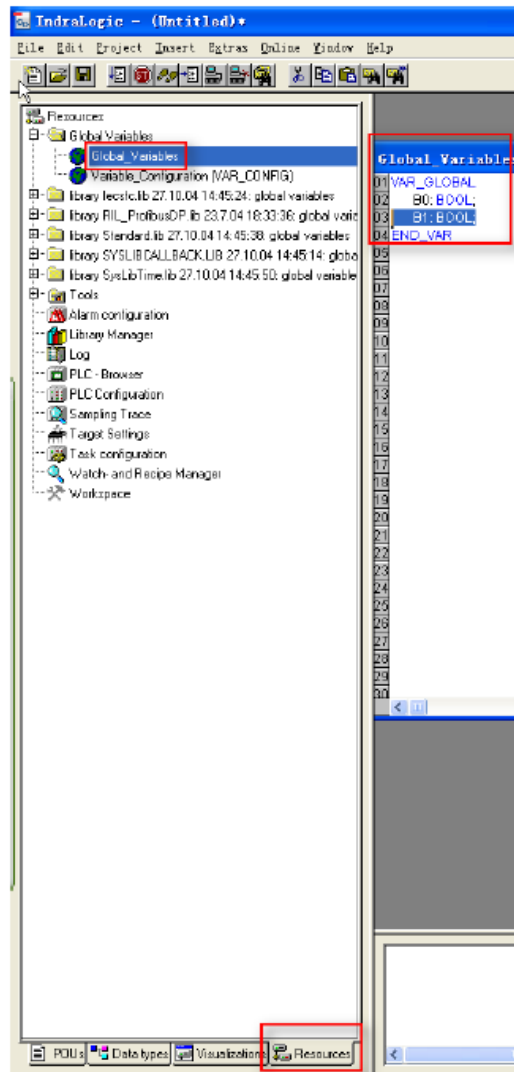

Then set the communication parameters:

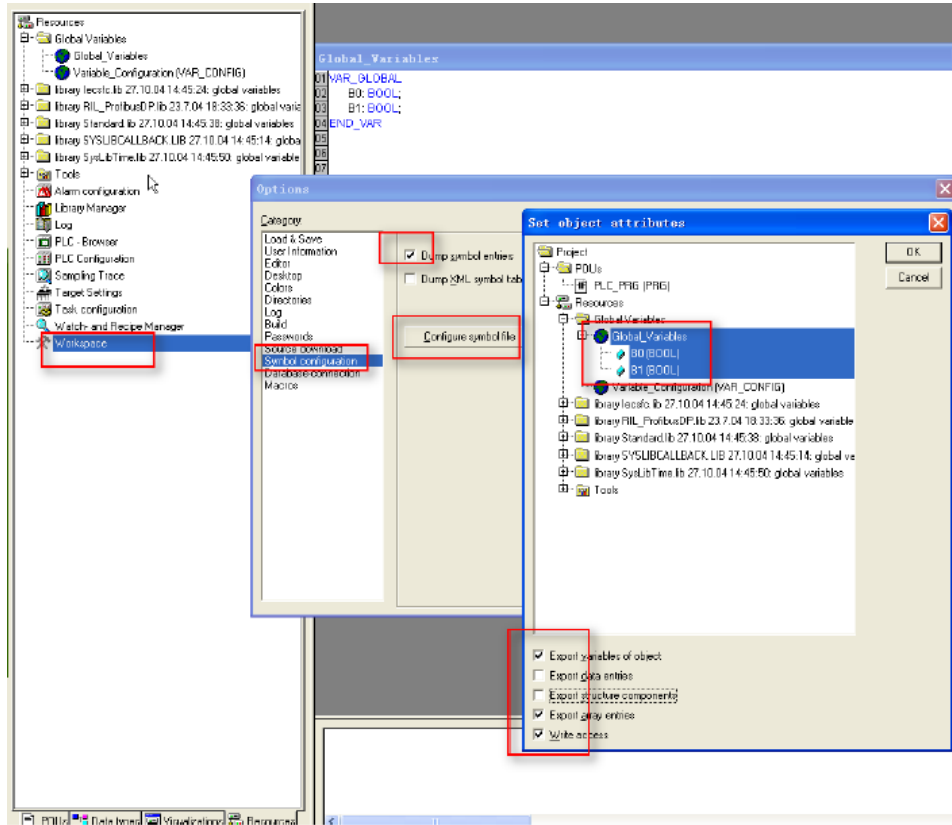

Click Login:

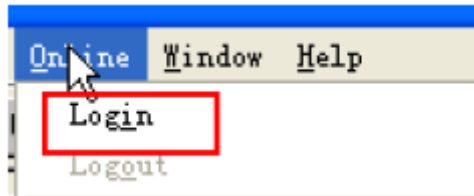

Note: the PLC panel needs to be set. Press enter, then Δ, until RS232 is displayed, and then press enter to enter the com SERV interface (if it is not SERV, it should be changed to SERV).



After setting, the serial communication between touch screen and PLC can be realized.

2.10.3 Cable making

IndraControl L40 PLC RS232:

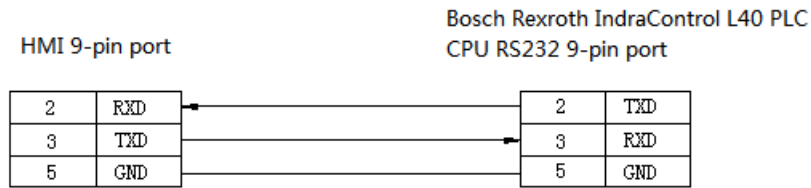

Fig1

2.10.4 Device address

IndraControl L40 series PLC

PLC address	Range	Data type	Explanation
X	0~9999	Bit	External I/O coil
B	0~9999	Byte	Used as register
W	0~9999	Word	Used as register
D	0~9999	DWord	Used as register
R	0~9999	DWord	Used as register
SB	0~9999	Byte	Used as register
SW	0~9999	Word	Used as register
SD	0~9999	DWord	Used as register

2.11 Delta AS series PLC

2.11.1 Device type

Series	CPU	Connection module	Port	Cable	PLC model in Touchwin software
300 series	AS332T/P-A AS324MT-A AS320T/P-B AS300N-A	Direct connect to the CPU	RS485	Fig 1	Delta ModbusRTU(AS)
200 series	AS228T/P/R-A AS218TX/PX/RX-A		RJ45	Fig2	Delta (AS series Ethernet)

2.11.2 Parameter

1. RS485 communication

HMI

Parameters	Recommend settings	Choices of settings	Notes
PLC type	Delta ModbusRTU(AS)		
Port	RS485	RS232 or RS485	
Data bit	8	7 or 8	
Stop bit	1	1 or 2	
Parity	Even parity	Even/odd/no parity	
Baud rate	9600	4800/38400/9600/115200/19200/187500	
Station no.	1	0~255	

2. RJ45 communication

PLC settings

(a)Open the PLC programming software, as shown in Figure 1. Double click in the project management area to open HWCONFI.

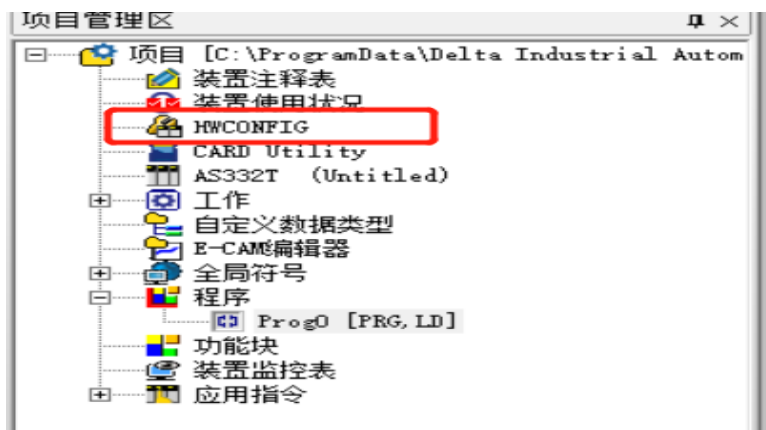

Fig 1

(b) Pop up the interface, double-click

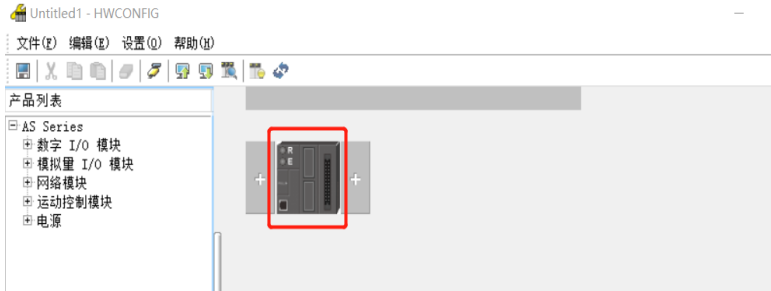
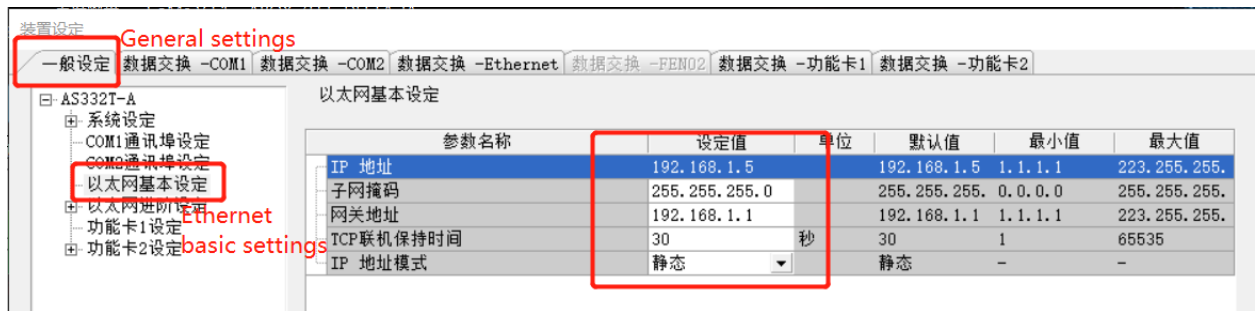

Fig 2

(c) General settings-Ethernet basic settings-IP address



HMI settings

(a) After selecting the HMI model as TN (- ET), TG (- ET) or TE(- ET), click next, and select "Net device" in the device list. In local device, IP address: the IP address of the HMI, as long as it does not conflict with other IPs in the network. In this example, the PLC station number is 192.168.1.5, and its own device can be set to 192.168.1.11.

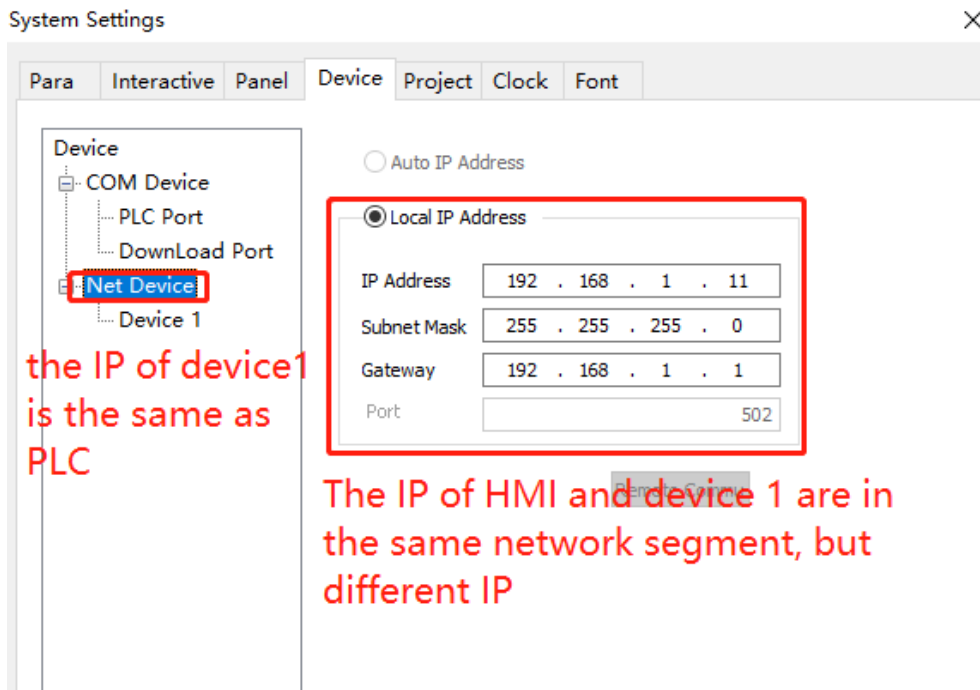

(b) Right click net device, build a new Ethernet device.

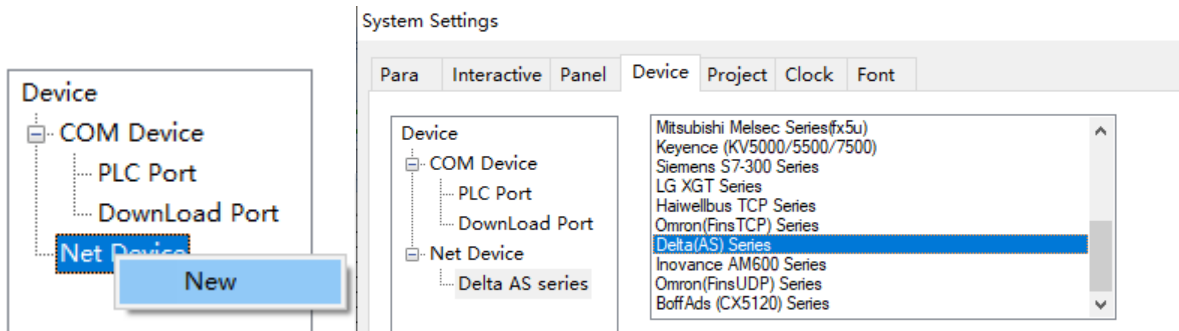

(c) Select “Delta AS series” in the equipment list. This IP address is the IP address of Delta PLC, and the port number is the "local port number" (decimal) set in PLC software

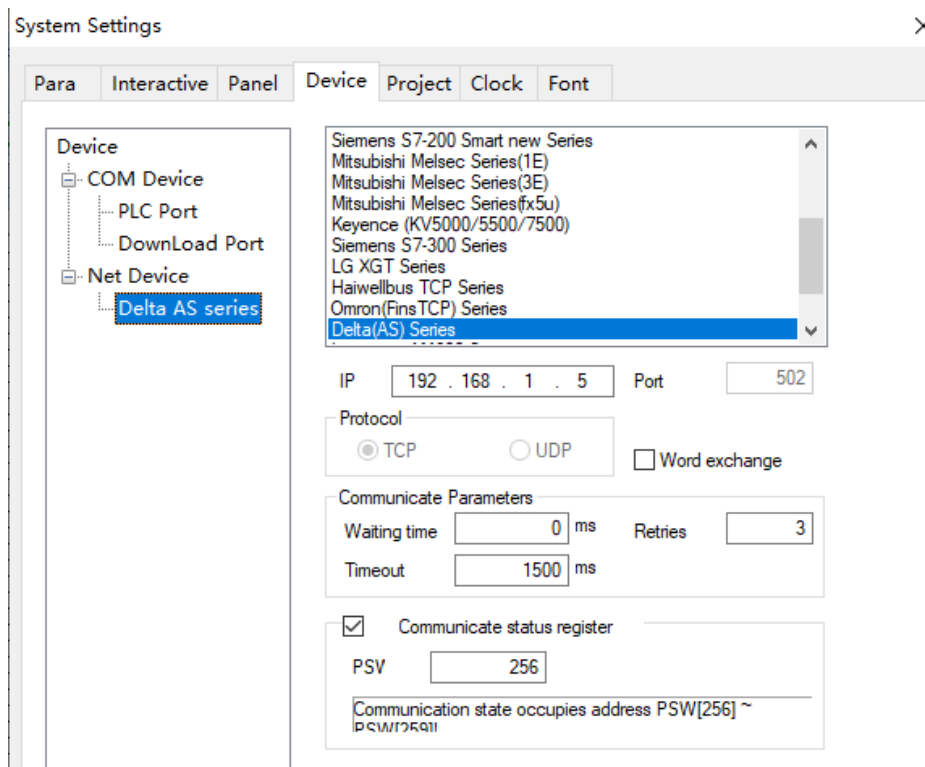

(d) For the setting of communication parameters, the communication status can be output by default: check “output communication status”, set PSW to 256, and select PSW256 ~ PSW259 as the number of communication successes, communication failures, communication timeouts and communication errors respectively. The output communication status address can be set by customers.

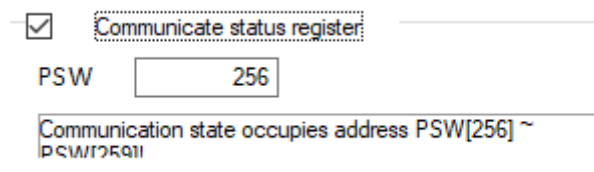

(e) After setting, click “next” to end the setting and enter the screen editing interface. Place data input part on the screen and select the corresponding equipment “XD series” in the equipment drop-down bar:

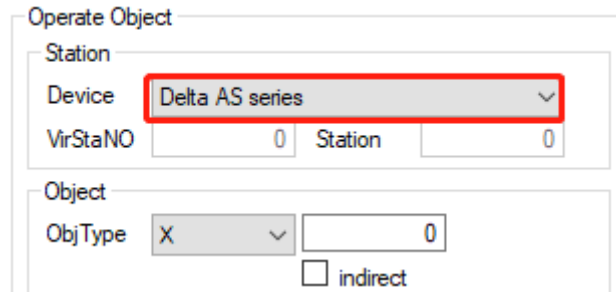

2.11.3 Cable making

(1)Delta AS series CPU(RS485 port)

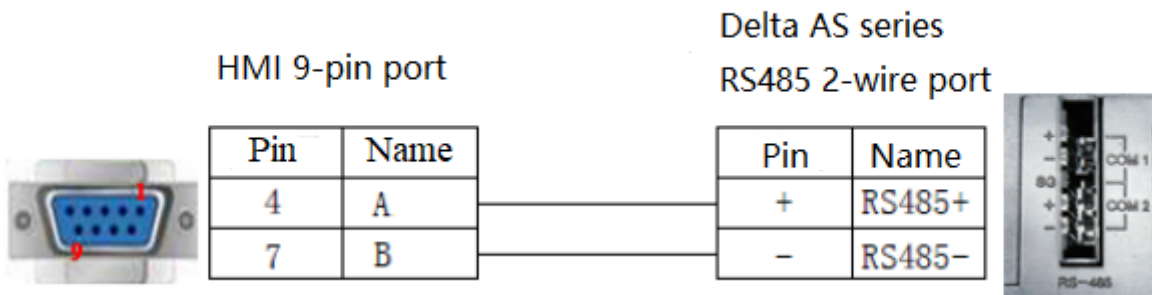

Fig 1

(2)RJ45 straight through cable (connected to hub) or RJ45 crossover cable:

pin	colour	pin	colour
1	white orange	1	white green
2	orange	2	green
3	white green	3	white orange
4	blue	4	blue
5	white blue	5	white blue
6	green	6	orange
7	white brown	7	white brown
8	brown	8	brown

Fig 2

2.11.4 Device address

PLC address	Range	Data type	Explanation
X	0.0~63.15	Bit	Input
Y	0.0~63.15	Bit	Output
M	0~8191	Bit	Internal relay
S	0~2047	Bit	Step relay
T	0~511	Bit	Timer

C	0~511	Bit	Counter
HC	0~255	Bit	32-bit counter
D	0~29999	Word	Data register
E	0~9	Word	Data register
SR	0~2047	Word	Special data register

2.12 Delta DVP series PLC

2.12.1 Device type

Delta DVP series CPU	Connected module	Port	Cable	PLC model in Touchwin software
DVP-ES/EH/EX	Direct connect to the CPU	RS232	Fig 1	Delta DVP series
DVP-SS/SA/SC/SX		RS485	Fig 2	
		RS232	Fig 1	
		RS485	Fig 2	

2.12.2 Parameters

HMI:

Parameters	Recommend settings	Choices of settings	Notes
PLC type	Delta DVP series		
Port	RS232	RS232 or RS485	
Data bit	7	7 or 8	
Stop bit	1	1 or 2	
Parity	Even parity	Even/odd/no parity	
Baud rate	9600	4800/38400/9600/115200/19200/187500	
Station no.	1	0~255	

The default communication parameters of Delta DVP series PLC: 9600, 7, 1, even parity, station no.1.

2.12.3 Cable making

(a) The RS232 port on CPU:

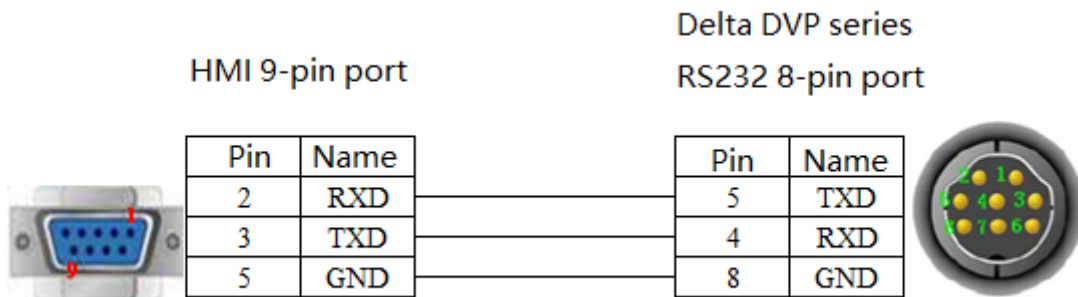

Fig 1

(b) RS485 port on CPU:

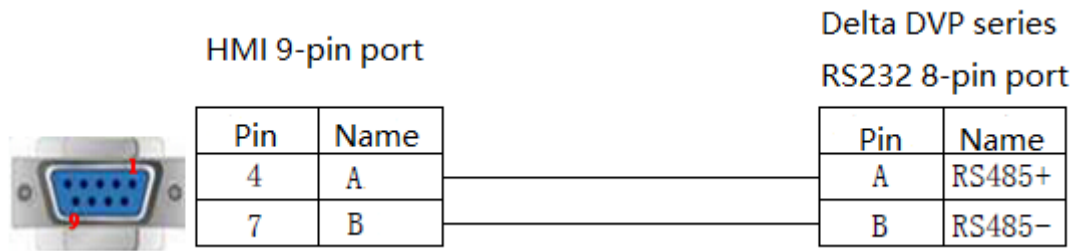

Fig2

2.12.4 Device address

PLC address	Range	Data type	Explanation
X	0~377	Bit	External input coil
Y	0~377	Bit	External output coil
M	0~1279	Bit	Internal auxiliary relay
S	0~1023	Bit	Stepper coil
T	0~255	Bit	Timer
C	0~255	Bit	Counter
D	0~1279	Word/DWord	Data register
TD	0~255	Word/DWord	Current value of timer
CD	0~255	Word/DWord	Current value of counter
S	0~1023	Word/DWord	Data register
X	0~377	Word/DWord	Data register
Y	0~377	Word/DWord	Data register
M	0~127	Word/DWord	Data register

2.13 Delta (temperature controller)

2.13.1 Device type

Series	CPU	Connected module	Port	Cable	PLC model in Touchwin software
DTA DTC	DTA4848 DTA9696VR DTC1000 DTC2000	CPU	RS485	Fig 1	Modbus RTU (panel is master)

2.13.2 Parameters

HMI settings:

Parameters		Choices of settings	Notes
PLC type	Modbus RTU (panel is master)	-	-
Data bit	7	-	
Stop bit	1	-	
Parity	Even parity	Even/odd/no parity	
Baud rate	9600	4800/9600/19200/38400/56000/57600/ 115200/187500	
Station no.	1	-	

Delta (temperature controller) default parameters: 9600, 7, 1, even parity, station no.1

2.13.3 Cable making

DTA/DTC RS485

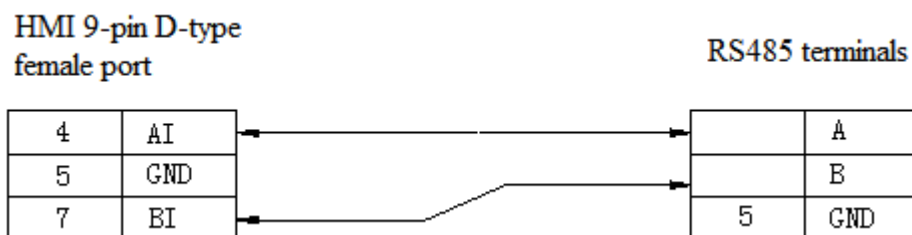

Fig1

2.13.4 Device address

Please refer to Delta temperature controller Modbus address list.

The address is decimal in HMI.

0x: read/write coil 1x: only read coil 4x: read/write register 3x: only read register

2.14 Emerson EC20 series PLC

2.14.1 Device type

Series	CPU	Connected module	Port	Cable	PLC model in Touchwin software
EC20	EC20	COM0 port	RS232	Fig 1	Emerson EC20 Series PLC
		COM1 port	RS485	Fig 2	
			RS232	Fig 3	

2.14.2 Parameters

HMI:

Parameters	recommend settings	Choices of settings	Note
PLC type	Emerson EC20 series PLC		
Port	RS232	RS232/RS485	
Data bit	8	7 or 8	
Stop bit	1	1 or 2	
Parity	Even parity	Even/odd/no parity	
Baud rate	19200	4800/38400/9600/115200 /19200/187500	
Station no.	1	0~255	

The default parameters of Emerson EC20 series PLC: 19200, 8, 1, even parity, station no.1

PLC settings:

(1) COM0 port setting



(2)COM1 port setting

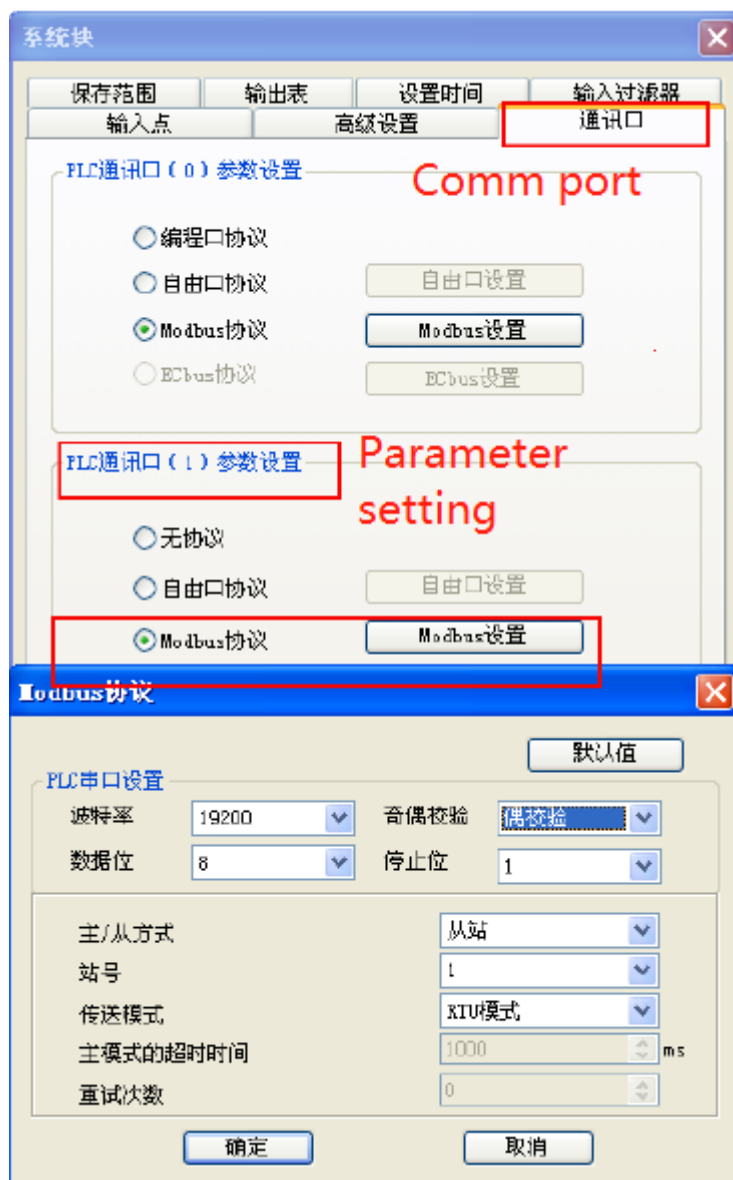

2.14.3 Cable making

(a) Emerson EC20 PLC COM0 (RS232):

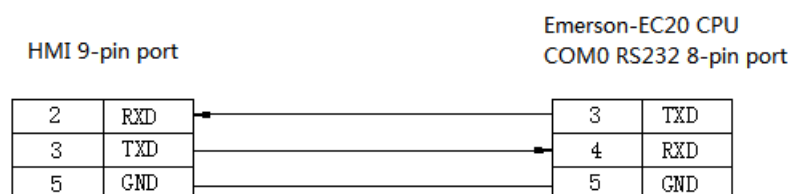

Fig1

(b) Emerson EC20 PLC COM1 (RS232):

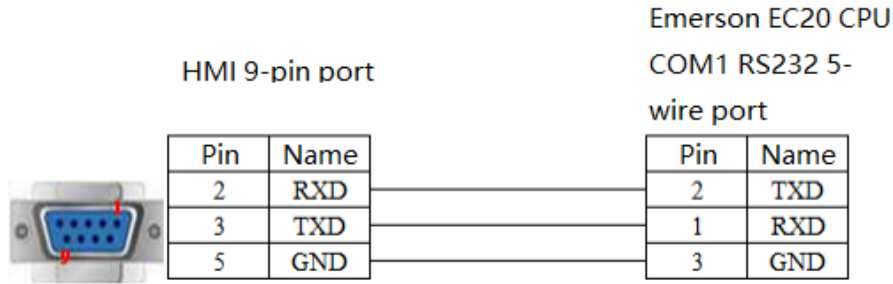

Fig2

(c) Emerson EC20 PLC COM1 (RS485):

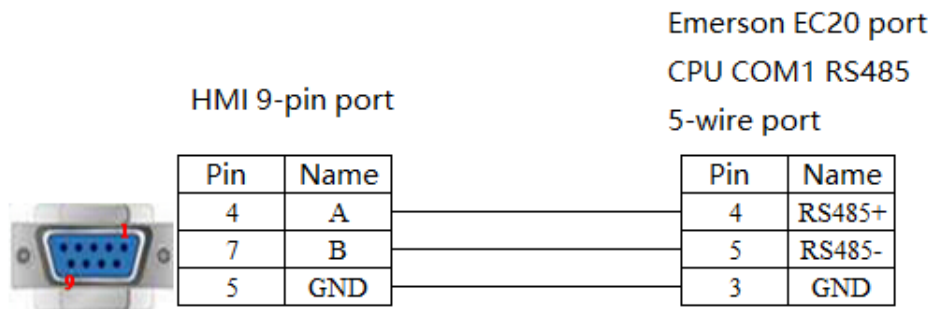

Fig3

Note: Emerson EC20 PLC COM1 supports RS232 and RS485.

2.14.4 Device address

PLC address	Range	Data type	Explanation
X	0~377	Bit	Input
Y	0~377	Bit	Output
M	0~2047	Bit	Internal coil
S	0~1023	Bit	Special coil
T	0~255	Bit	Timer
C	0~255	Bit	Counter
SM	0~255	Bit	Special internal auxiliary relay
D	0~7999	Word/DWord	Data register
SD	0~255	Word/DWord	Used as register
Z	0~15	Word	Used as register
T	0~255	Word/DWord	Used as register
C16	0~199	Word	16-bit counter
C32	200~255	DWord	32-bit counter

2.15 Fatek FB series PLC

2.15.1 Device type

Series	CPU	Connected module	Port	Cable	PLC model in Touchwin software
FBs B1	FBs -20MN FBs -32MN FBs -44MN B1-10/14/20/24M	Direct connect to CPU	RS232	Fig 1	Fatek MU/MA series
			RS485	Fig 2	
FB-MC	20MC 28MC 40MC 19MCT 26MCT 36MCT		RS232	Fig 1	
			RS485	Fig 2	
FB-MA	20MA 28MA 40MA		FB-DTBR/DTBR-E module	RS232	
		RS232		Fig 4	
		RS485		Fig 5	

Note: MA series PLC needs to configure FB-DTBR or FB-DTBR-E module, uses RS232 or RS485 connection.

2.15.2 Parameters

HMI:

Parameters	Recommend settings	Choices of settings	Note
PLC type	Fatek (MU/MA) series PLC		
Port	RS232	RS232 or RS485	
Data bit	7	7 or 8	
Stop bit	1	1 or 2	
Parity	Even parity	Even/odd/no parity	
Baud rate	9600	4800/38400/9600/115200 /19200/187500	
Station no.	1	0~255	

The default parameters of Fatek MC/MA/MU series PLC: 9600, 7, 1, even parity, station no.1.

2.15.3 Cable making

(a) FBs Port0 RS232:

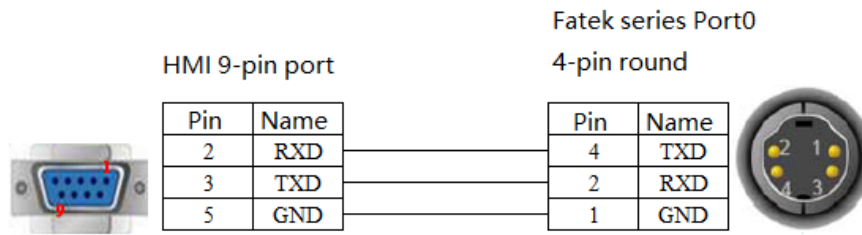

CPU port:

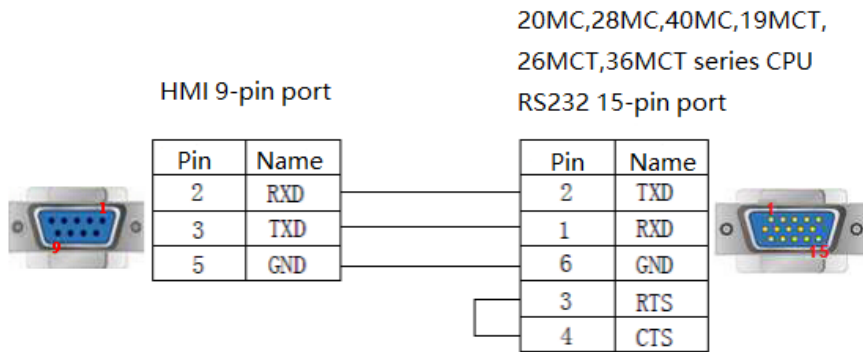

Fig1

(b)CPU RS485:

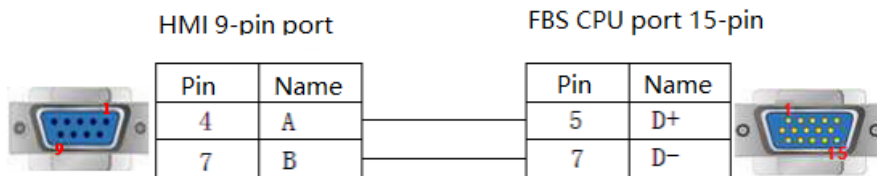

Fig2

(c)FB-DTBR/DTBR-E module RS232:

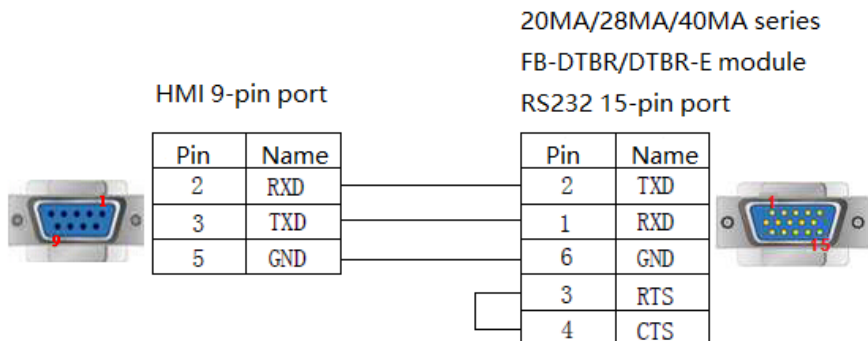

Fig3

(d)FB-DTBR/DTBR-E module RS232:

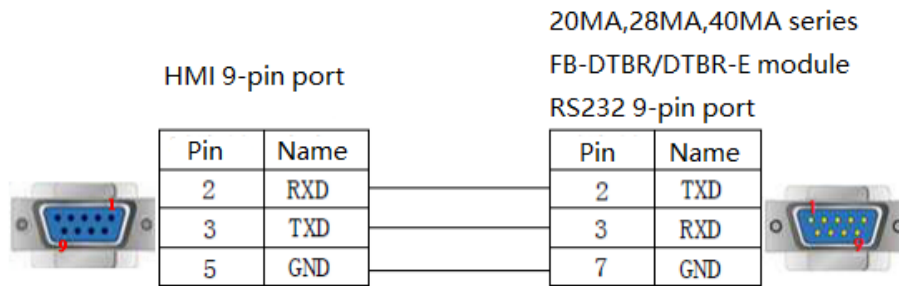

Fig4

(e) FB-DTBR/DTBR-E module RS485:

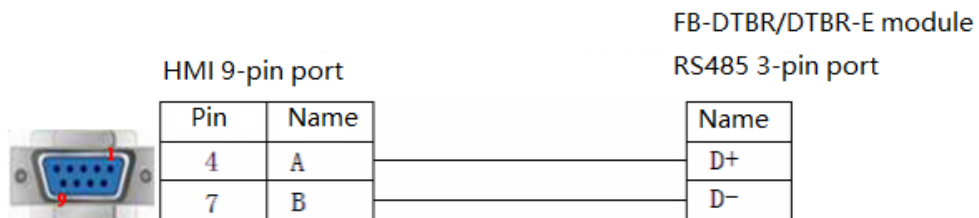

Fig5

2.15.4 Device address

FATEK-FB series PLC

PLC address	Range	Data type	Explanation
M	0~2001	Bit	Internal auxiliary coil
X	0~255	Bit	External input coil
Y	0~255	Bit	External output coil
S	0~999	Bit	Sequence control coil
T	0~255	Bit	Timer
C	0~255	Bit	Counter
R	0~9000	Word/Dword	Register
X	0~255	Word/Dword	Used as register
Y	0~255	Word/Dword	Used as register
M	0~2001	Word/Dword	Used as register
S	0~999	Word/Dword	Used as register
D	0~3071	Word/Dword	Used as register
TD	0~255	Word/Dword	Used as register
C16	0~199	Word/Dword	16-bit counter
C32	200~255	Word/Dword	32-bit counter

2.16 Fuji SPB series PLC

2.16.1 Device type

Fuji MICREX-SX SPB series PLC

Series	CPU	Connected module	Port	Cable	PLC model in Touchwin software
SPB	NWOP20	Communication adapter NWOLA-RS2	RS232	Fig 1	Fuji SPB series PLC
	NWOP30	Communication adapter NWOLA-RS4	RS485	Fig 2	
	NWOP40	Direct connect to the CPU	RS422	Fig 3	
NB	NB2U24R-11	Direct connect to the CPU	RS422	Fig 3	

2.16.2 Parameters

HMI:

Parameter	Recommend settings	Choices of settings	Note
PLC type	Fuji SPB series PLC		
Port	RS422	RS232/RS485/RS422	
Data bit	8	7 / 8	
Stop bit	1	1 / 2	
Parity	Odd parity	Even/odd/no parity	
Baud rate	19200	4800/38400/9600/115200/19200/187500	
Station no.	0	0~255	

2.16.3 Cable making

(a) NWOLA-RS2 module RS232:

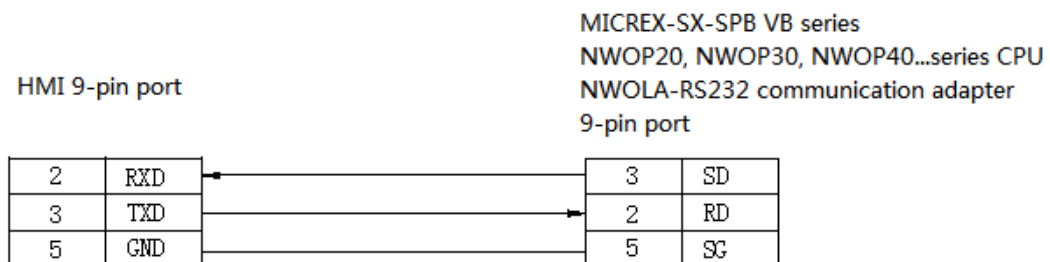

Fig1

(b) NWOLA-RS4 module RS485:

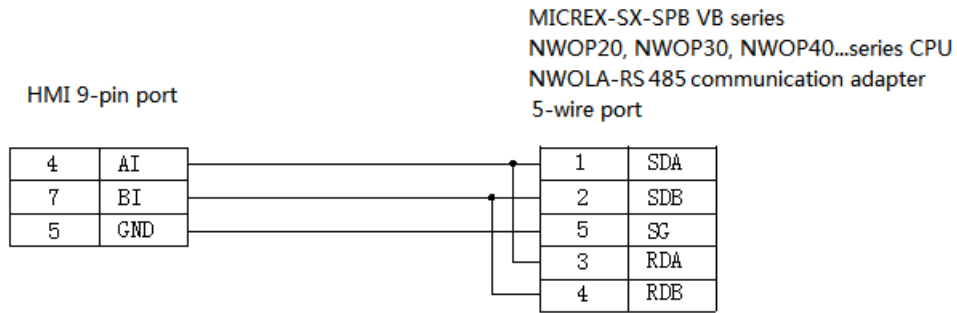

Fig2

(c) RJ-45 RS422:

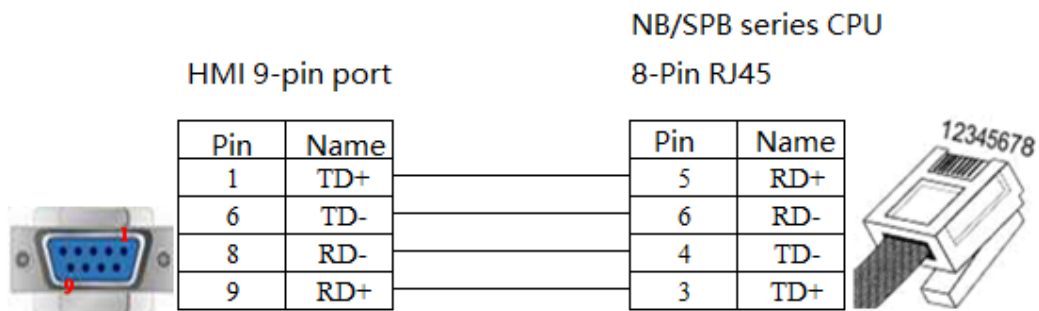

Fig3

2.16.4 Device address

PLC address	Range	Data type	Explanation
X	0~15	Bit	External input coil
Y	0~15	Bit	External output coil
M	0~15	Bit	Internal auxiliary coil
L	0~15	Bit	Special auxiliary coil
T	0~511	Bit	Timer
C	0~255	Bit	Counter
SM	0~15	Bit	Special auxiliary coil
WX	0~63	Word/DWord	Used as register
WY	0~63	Word/DWord	Used as register
WM	0~63	Word/DWord	Used as register
WL	0~255	Word/DWord	Used as register
WSM	32768~33023	Word/DWord	Used as register
D	0~8191	Word/DWord	Data register
TW	0~511	Word/DWord	Used as register
CW	0~255	Word/DWord	Used as register
LD	0~10000	Word/DWord	Used as register
SD	32768~33023	Word/DWord	Used as register

2.17 HaiWell PLC

2.17.1 Device type

Series	CPU	Connected module	Port	Cable	PLC model in Touchwin software
E/S	HW-S16ZR220R	CPU	RS232	Fig 1	Modbus RTU (Panel is Master)
			RS485	Fig 2	

2.17.2 Parameters

HMI settings:

Parameter	Recommend settings	Choices of settings	Notes
PLC type	Modbus RTU (panel is master)	-	-
Data bit	8	-	
Stop bit	2	-	
Parity	No parity	Even/odd/no parity	
Baud rate	9600	4800/9600/19200/38400/ 56000/ 57600/115200/187500	
Station no.	1	-	

Haiwell E/S series default communication parameters: 9600, 8, 2, no parity, station no.1

PLC settings:

Communication protocol: Modbus RTU.

2.17.3 Cable making

(a) E/S series PLC RS232:

Haiwell PLC port	RS232 connection	HMI port
 <p>4-pin S-type male port (same to programming cable)</p>	<p>TX 2 ——— 2 RXD</p> <p>RX 1 ——— 3 TXD</p> <p>GND 3 ——— 5 GND</p>	 <p>9-pin D-type female port</p>

Fig 1

(b)E/S series PLC RS485:

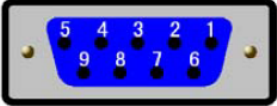
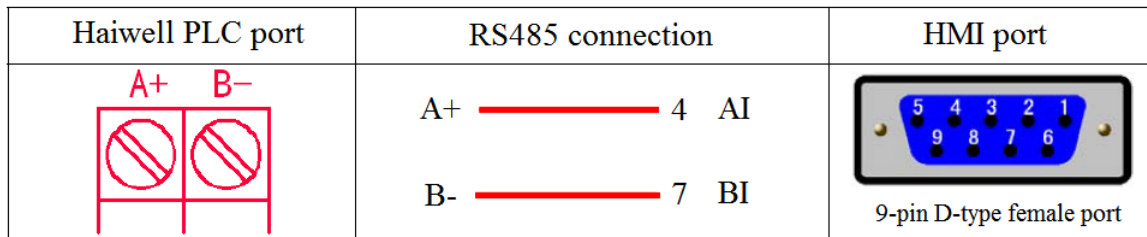

Fig 2

2.17.4 Device address

PLC address	Range	Modbus address	Read/write	Explanation
X	X0~X1023	0~1023	Read	Input
Y	Y0~Y1023	1536~2559	Read/write	Output
M	M0~M12287	3072~15359	Read/write	Internal coil
T	T0~T1023	15360~16383	Read/write	Timer
C	C0~C255	16384~16639	Read/write	Counter
SM	SM0~SM215	16896~17111	Read/write partly	System state bit
S	S0~S2047	28672~30719	Read/write	Stepper state bit
CR		00~4F	Read/write partly	Register for analog and special module
AI	AI0~AI255	0000~00FF	Read	Input register for analog
AQ	AQ0~AQ255	0100~01FF	Read/write	Output register for analog
V	V0~V14847	0200~3BFF	Read/write	Internal register
TCV	TCV0~TCV1023	3C00~3FFF	Read/write	Timer
CCV	CCV0~CCV255	4000~40FF	Read/write	Counter
SV	SV0~SV154	4400~448B	Read/write partly	System register

2.18 Haiwell bus TCP

2.18.1 Device type

Series name	Communication type	Cable making	PLC model in Touchwin software
Haiwell PLC	RJ45	Fig 1 or 2	Haiwellbus TCP protocol

2.18.2 Parameters

Take Haiwell PLC as an example to explain the communication settings.

PLC settings:

Open the PLC software, set the PLC IP to 192.168.1.111 for example.

HMI settings:

1. choose HMI model TN(-ET), TG(-ET) or TE(-ET), click next, then choose net device, fill in the IP address of HMI. The HMI IP cannot be conflict with other devices in the network. For example, the HMI IP is set to 192.168.1.11.

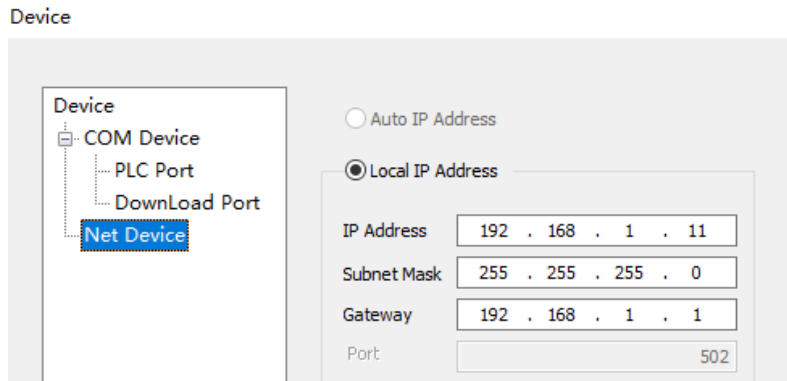

2. right click the net device, build a new project, and name it as Haiwellbus TCP.

3. choose Haiwellbus TCP protocol in the list, and fill in the PLC IP address, the port is PLC port no. set in the PLC software.

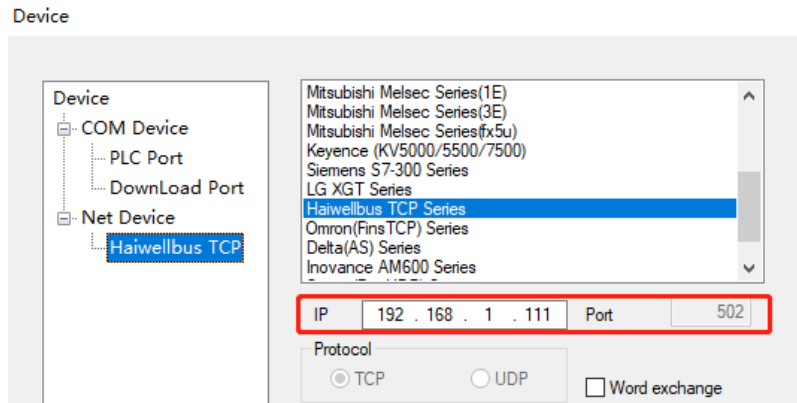

4. Please keep the communication parameters as default, if the communicate status register is selected, PSW256~PSW259 respectively indicate communication successful times, failed times, overtime times, error times. User can set the register address as needs.

Communicate status register

PSW

Communication state occupies address PSW[256] ~ PSW[259]

5. click next to finish the settings and enter screen edit interface. Put a data input button on the screen, and choose the Haiwellbus tcp in the device list.

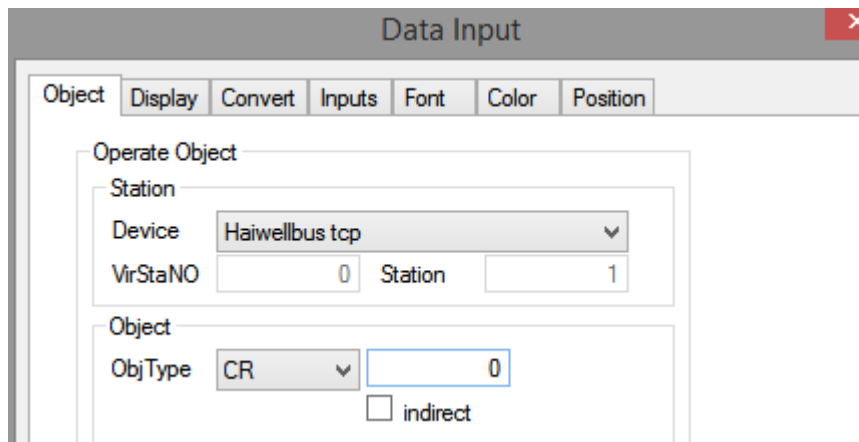

2.18.3 Cable making

RJ45 Straight Through Cable (connect HUB) or RJ45 Crossover Cable:

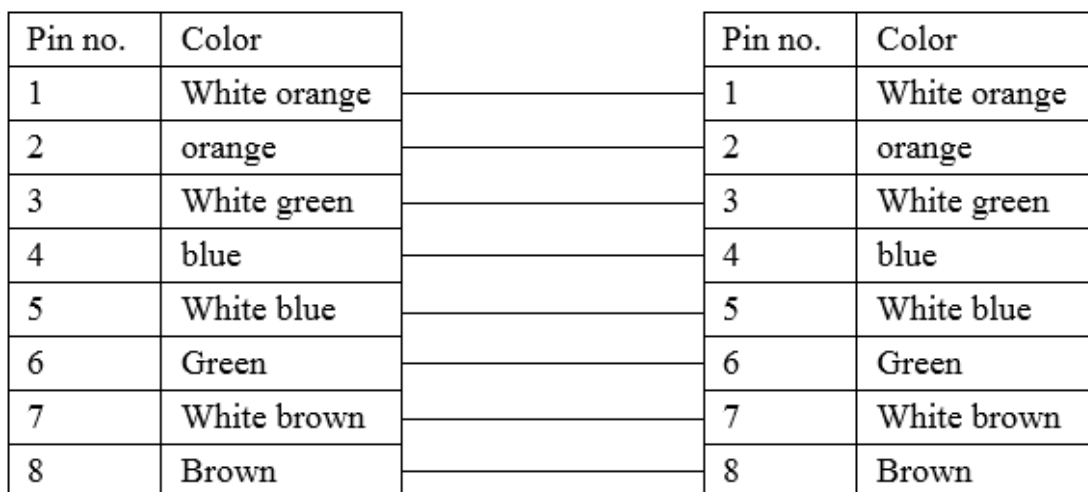

Fig 1

Pin no.	Color		Pin no.	Color
1	White orange	—————	1	White green
2	orange	—————	2	Green
3	White green	—————	3	White orange
4	blue	—————	4	blue
5	White blue	—————	5	White blue
6	Green	—————	6	orange
7	White brown	—————	7	White brown
8	Brown	—————	8	Brown

Fig 2

2.18.4 Device address

PLC address	Range	Object type	Notes
X	0~1023	Bit	Digital input
Y	0~1023	Bit	Digital output
M	0~12287	Bit	Internal relay
T	0~1023	Bit	Timer
C	0~255	Bit	Counter
SM	0~215	Bit	System status bit
S	0~2047	Bit	Step relay
CR	0~255	Word/DWord	Extended module parameter
AI	0~255	Word/DWord	Analog input
AQ	0~255	Word/DWord	Analog output
V	0~14847	Word/DWord	Internal register
TV	0~1023	Word/DWord	Timer
CV	0~255	Word/DWord	Timer
SV	0~900	Word/DWord	Step driver

2.19 Hollsys PLC

2.19.1 Device type

Series	CPU	Connected module	Port	Cable making	PLC model in Touchwin software
LM	LM3109	CPU	RS232	Fig 1	Modbus RTU (panel is master)
	LM3107		RS485	Fig 2	

2.19.2 Parameters

HMI settings:

Parameters	Recommend settings	Choices of settings	Note
PLC type	Modbus RTU (panel is master)	-	-
Data bit	8	-	
Stop bit	1	-	
Parity	No parity	Even/odd/no parity	
Baud rate	38400	4800/9600/19200/38400/56000/ 57600/115200/187500	
Station no.	51	-	

Hollsys LM series PLC default parameters: 38400, 8, 1, no parity, station no.51

2.19.3 Cable making

(a) LM series PLC RS232:

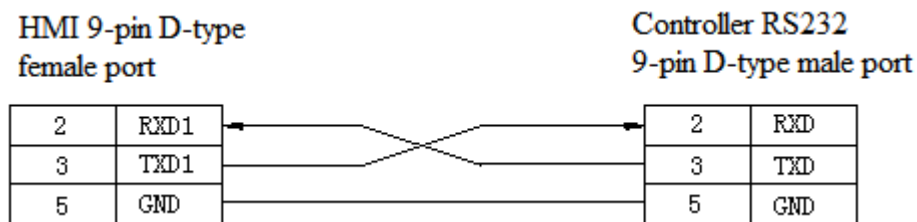

Fig1

(b) LM series PLC RS485:

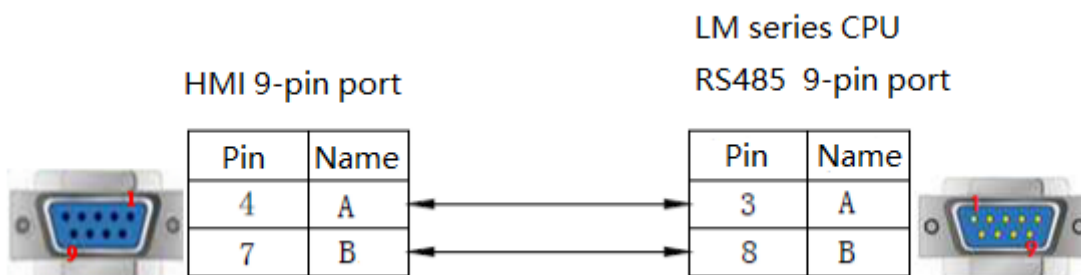

Fig2

2.19.4 Device address

Please refer to Hollias PLC Modbus address list.

The address is decimal value in HMI.

0x: read/write coil 1x: only read coil 4x: read/write register 3x: only read register

2.20 IDEC

2.20.1 Device type

Series	Connected module	Port	Cable	PLC model in Touchwin software
Micro3	Direct connect to CPU	RS485	Fig 1	IDEC MicroSmart
Micro3C	Direct connect to CPU	RS232	Fig 2	
	RS485	RS485	Fig 3	
MicroSmart	Direct connect to CPU	RS232	Fig 2	
	Communication adapter FC4A-PC2 RS485	RS485	Fig 1	
	Communication adapter FC4A-PC3 RS485	RS485	Fig 3	
Open Net	Direct connect to CPU	RS232	Fig 2	
	RS485	RS485	Fig 3	

2.20.2 Parameters

HMI settings:

Parameters	Recommend settings	Choices of settings	Note
PLC type	IDEC MicroSmart		
Port	RS232	RS232	
Data bit	7	7/8	
Stop bit	1	1/2	
Parity	Even parity	Even /odd /no parity	
Baud rate	9600	4800/38400/9600/115200/19200/187500	
Station no.	0		

2.20.3 Cable making

(a) RS485 connection:

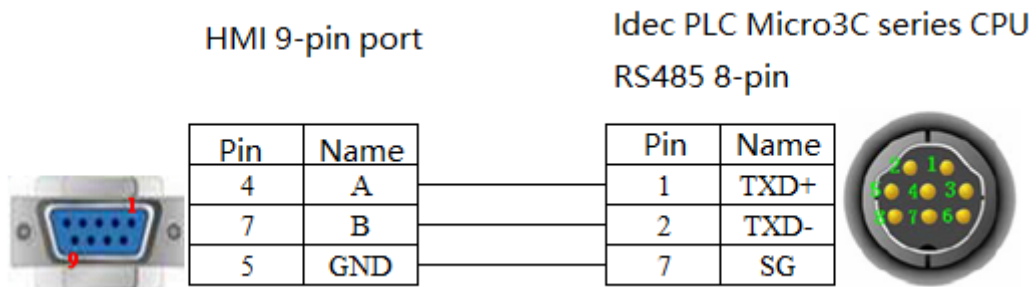

Fig 1

(b) RS232 connection

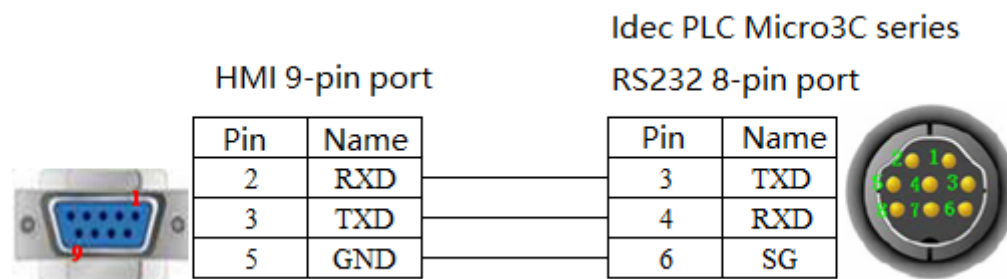

Fig 2

(c) RS485 terminal block wiring mode

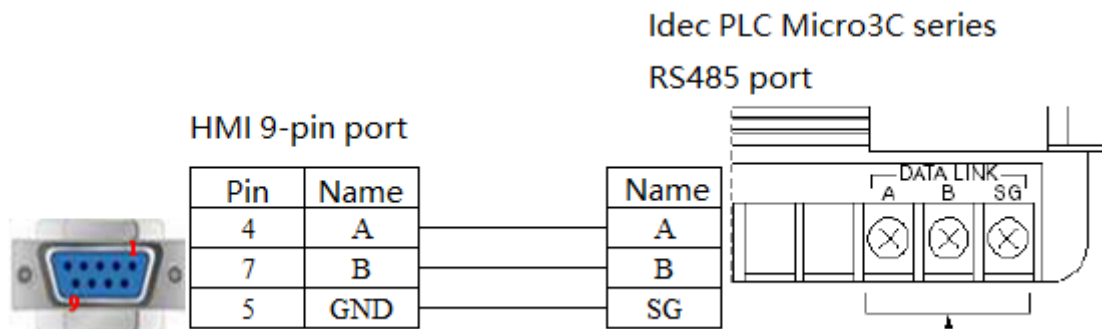

Fig 3

2.20.4 Device address

Device address	Range	Data type	Explanation
D	0~8199	Word/DWord	Data register
W	0~6	Word	Data register
T	0~99	Word	Timer
t	0~99	Word	Timer
C	0~99	Word	Counter
c	0~99	Word	Counter
R	0~127	Word	Data register
x	0.0~30.7	Bit	Input
y	0.0~30.7	Bit	Output
m	0.0~807.7	Bit	Auxiliary relay
r	127	Bit	Auxiliary relay

2.21 Inovance AM600 PLC

2.21.1 Device type

Series	CPU	Connected module	Port	Cable	PLC model in Touchwin software
AM600	AM600	CPU	RS485	Fig 1	Inovance AM600 series PLC

2.21.2 Parameters

HMI settings:

Parameters	Recommend settings	Choices of settings	Note
PLC type	Inovance AM600 series PLC		
Data bit	8	7/8	
Stop bit	1	1/2	
Parity	Even parity	Even /odd /no parity	
Baud rate	19200	4800/38400/9600/115200/19200/187500	
Station no.	1		

PLC settings:

(a)Serial port protocol settings

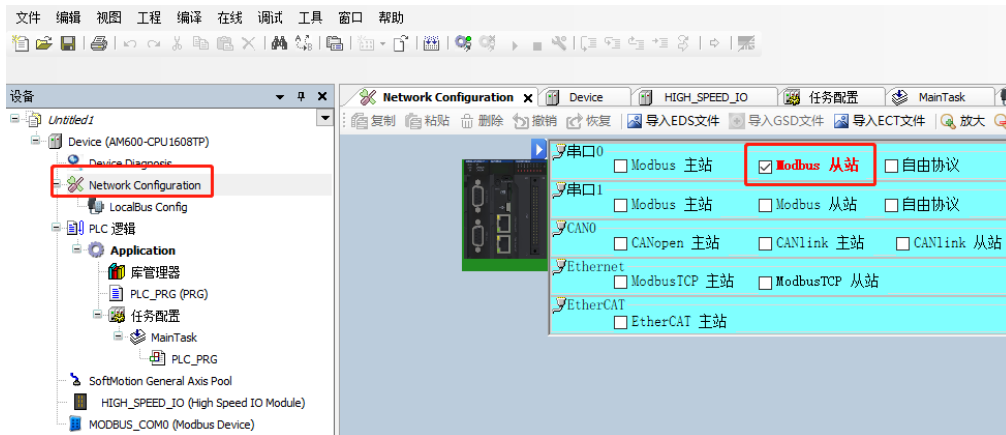

(b)Communication parameters

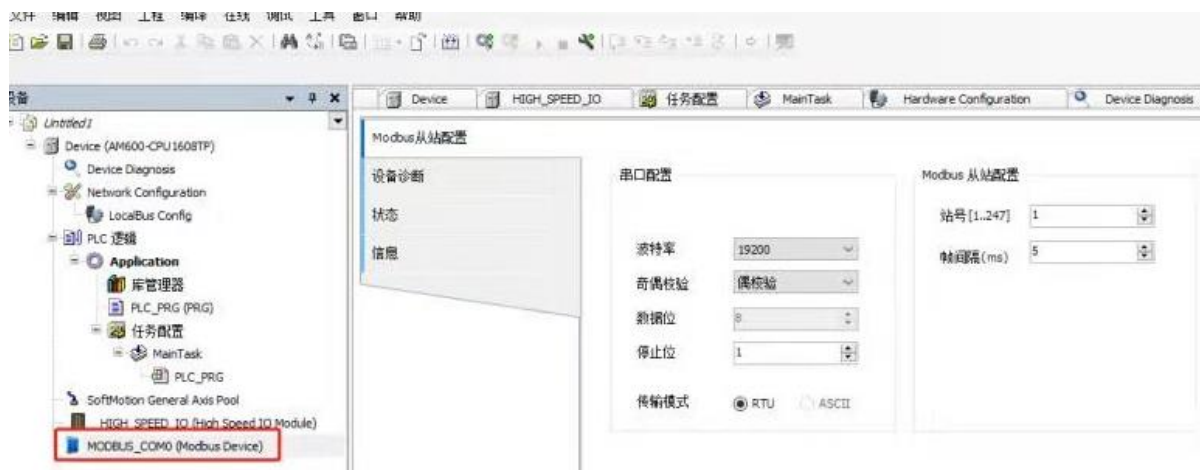

2.21.3 Cable making

RS485 connection

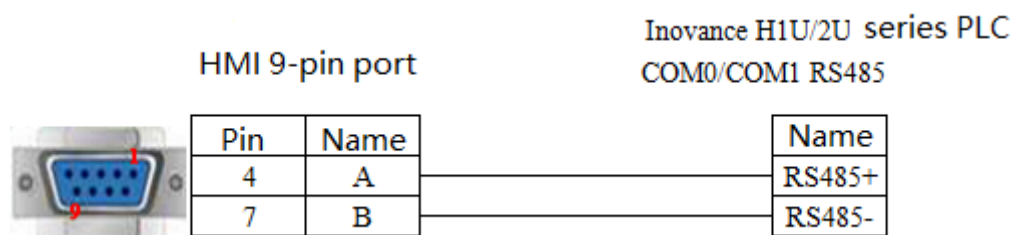

Fig 1

Note: For example, the serial port 0 is used for 485 communication, connect pin 1 and 2, and connect pin 6 and 9 when using serial 1 .

2.21.4 Device address

PLC address	Range	Object	Explanation
I	0~8191	Bit	input
Q	0~8191	Bit	output
M	0~65535	Word/DWord	Data register
SM	0~7999	BIT	System variable
SD	0~7999	Word/DWord	Register variable

2.22 Inovance AM600(Ethernet) PLC

2.22.1 Device type

Series	CPU	Connected module	Port	Cable	PLC model in Touchwin software
AM600	AM600	CPU	RJ45	Fig 1	Inovance AM600 series PLC

2.22.2 Parameters

PLC settings

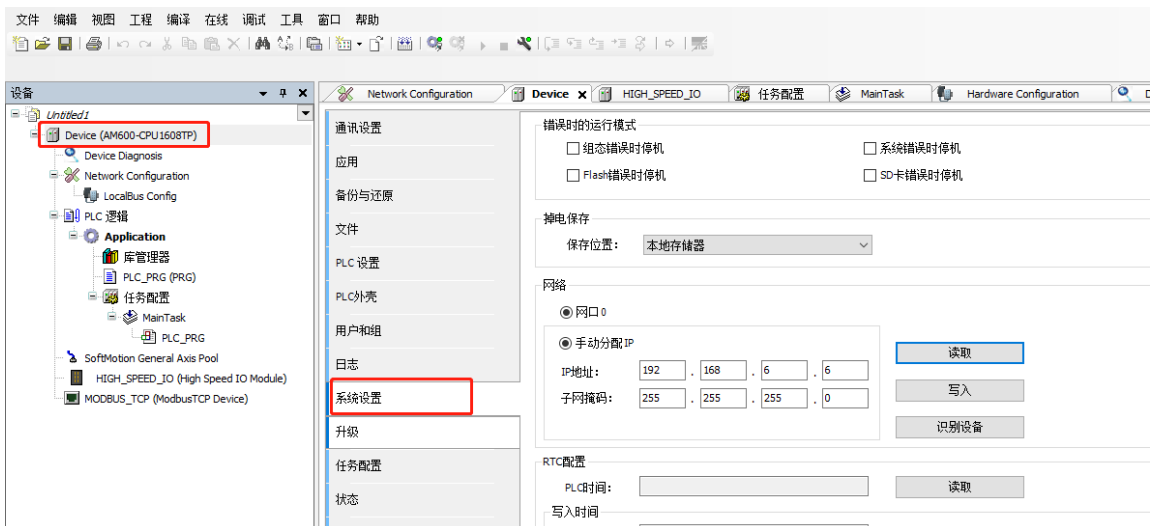
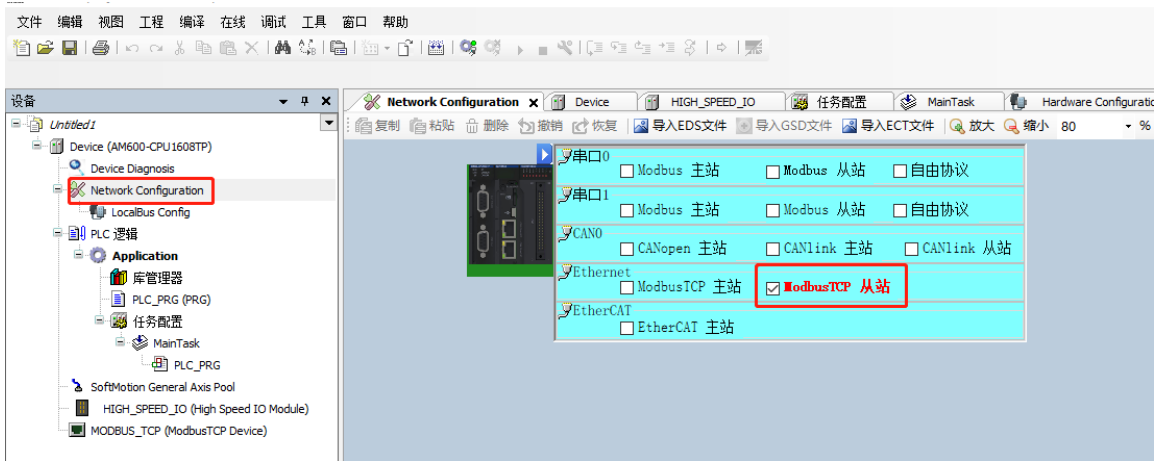

HMI settings

After selecting the human-machine interface model as TG(-ET), click next, and select “Net device” in the device list. In Local IP address: the IP address ,as long as it does not conflict with other IP address in the network. In this example, the IP of PLC is 192.168.6.6, and it can be set to 192.168.6.10.

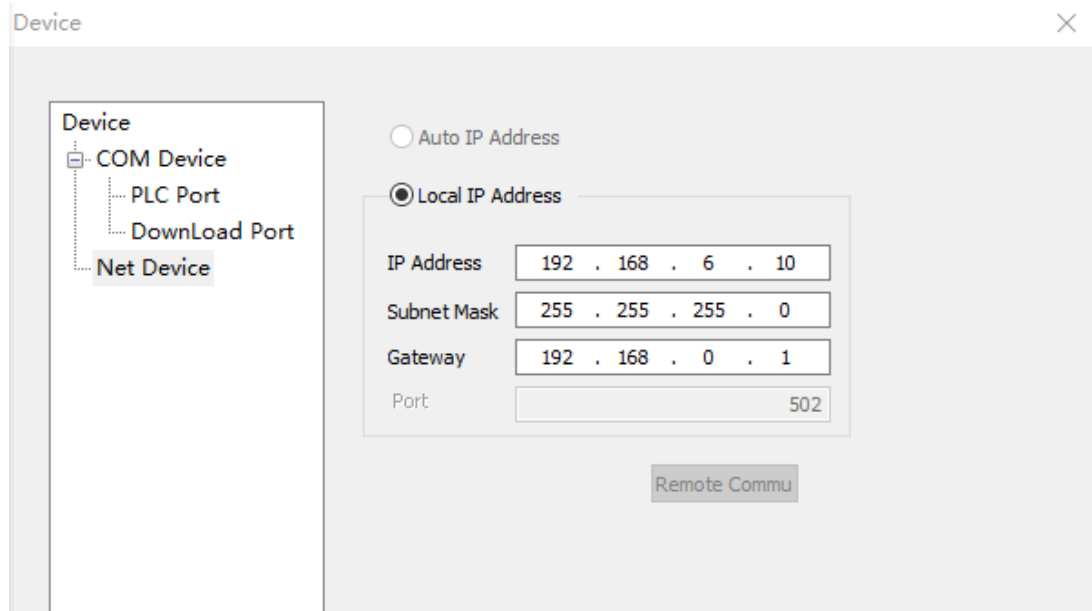

Right click net device, build a new Ethernet device.

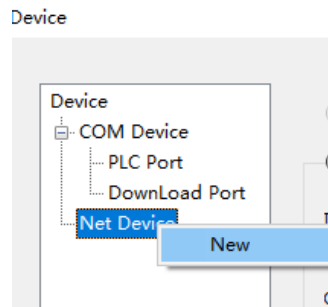

Select “Inovance AM600 series” in the equipment list.

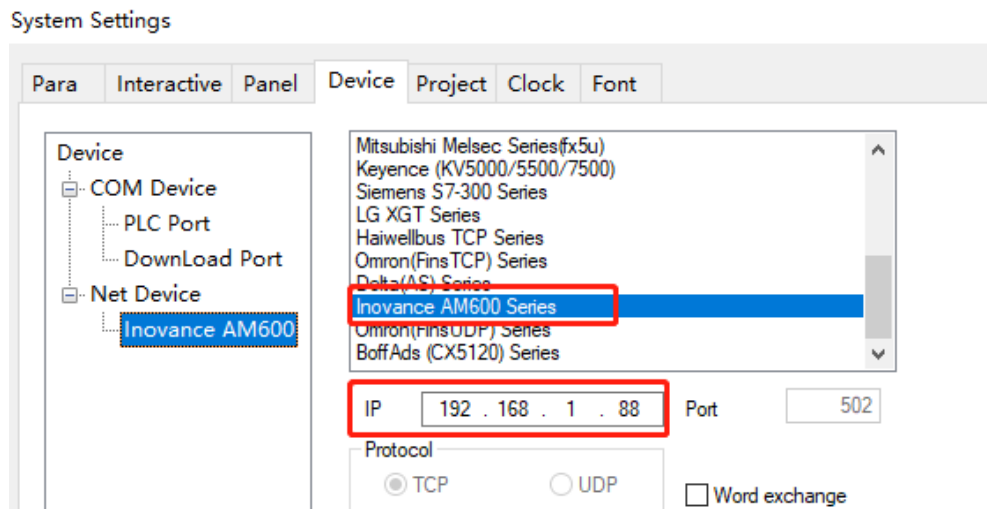

For the setting of communication parameters, the communication status can be output by default: check “output communication status”, set PSW to 256, and select PSW256 ~ PSW259 as the number of

communication successes, communication failures, communication timeouts and communication errors respectively. The output communication status address can be set by customers.

Communicate status register

PSW

Communication state occupies address PSW[256] ~ PSW[259]

2.22.3 Cable making

AS200/300 series PLC RS485:

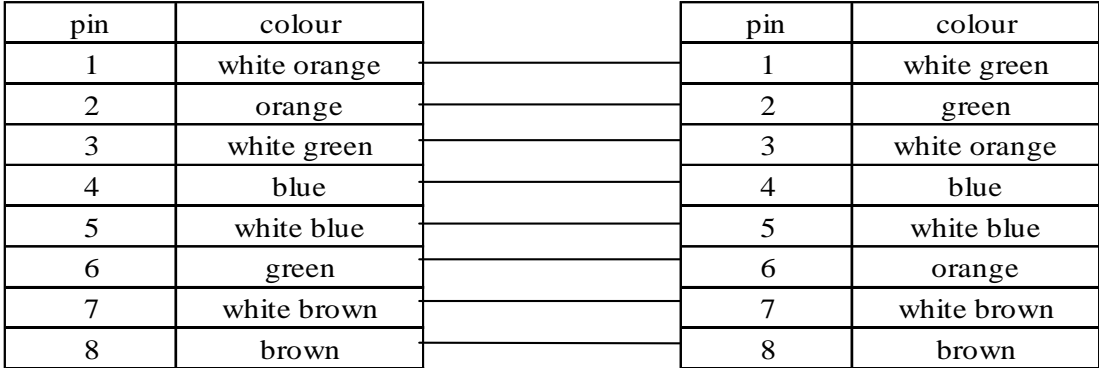

Fig 1

2.22.4 Device address

PLC address	Range	Object	Explanation
I	0~8191	Bit	input
Q	0~8191	Bit	output
M	0~65535	Word/DWord	Data register
SM	0~255	BIT	System variable
SD	0~7999	Word/DWord	Register variable

2.23 Inovance H2U/H1U PLC

2.23.1 Device type

Series	CPU	Connected module	Port	Cable	PLC model in Touchwin software
H1U	H1U-0806MR/T H1U-1410MR/T H1U-1614MR/T	CPU	RS422	Fig 1	Mitsubishi FX series PLC
			RS485	Fig 2	
H2U	H2U-1616MR/T H2U-2416MR/T H2U-3624MR/T		RS422	Fig 1	
RS485			Fig 2		

2.23.2 Parameter

HMI settings

Parameter	Recommended settings	Choices of settings	Notes
PLC type	FX series	-	-
Data bit	7	-	-
Stop bit	1	-	-
Parity	Even parity	Even/odd/no parity	-
Baud rate	9600	4800/9600/19200/38400/56000/ 57600/ 115200/187500	-
Station no.	0	-	-

Inovance H1U/H2U series default communication parameters: 9600, 7, 1, even, statio no.0.

PLC settings:

(1) COM0:



Note: Short circuit JP0, representing COM0 RS422 (Mini DIN8 female). Short circuit JP0, set D8116 as H01 in the program, download the program, disconnect JP0 and power on again, which means COM0 RS485 (screw terminal) is used.

(2)COM1:



Note: Short circuit jp0, set D8126 to 1 in the PLC program, download the program, and use COM1 RS485 (screw terminal).

2.23.3 Cable making

(a) H1U/2U series PLC RS422 port:

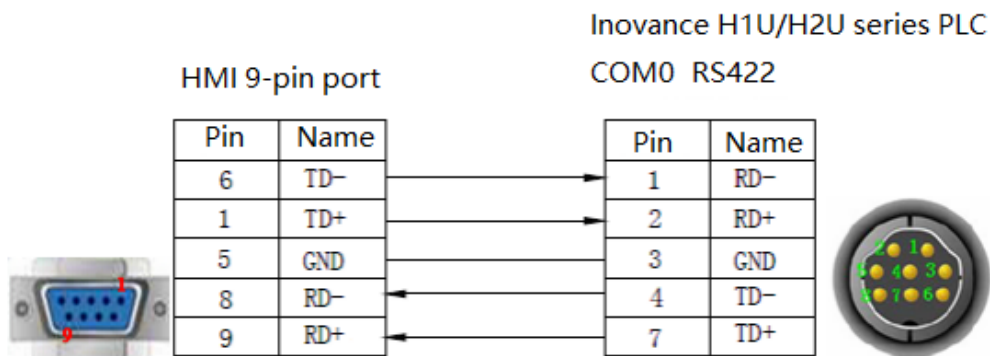

Fig1

(b) H1U/2U series PLC RS485 port:

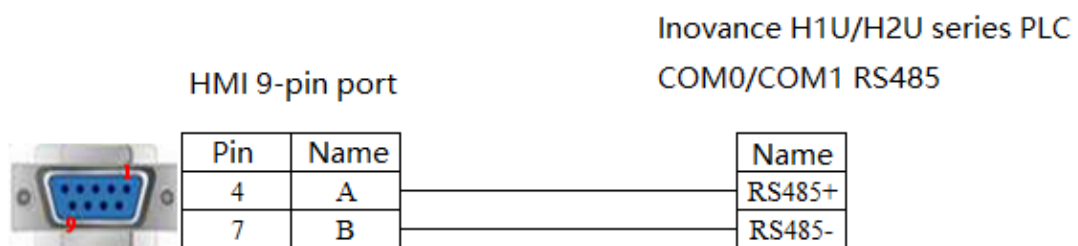

Fig 2

2.23.4 Device address

PLC address	Range	Object	Explanation
X	0~177	Bit	External input terminal
Y	0~177	Bit	External output terminal
M	0~8255	Bit	Internal auxiliary coil
S	0~999	Bit	Stepper coil
T	0~255	Bit	Timer
C	0~255	Bit	Counter
C16	0~199	Word/DWord	16-bit counter
C32	200~255	DWord	32-bit counter
D	0~8255	Word/DWord	Data register
T	0~255	Word/DWord	Current value
X	0~177	Word/DWord	Used as data register
Y	0~177	Word/DWord	Used as data register
M	0~8255	Word/DWord	Used as data register
S	0~999	Word/DWord	Used as data register

2.24 Keyence KV series PLC

2.24.1 Device type

CPU	Connected module	Port	Cable	PLC model in Touchwin software
KV-10DR KV-24 KV-16 KV-40 KV-1000 KV-3000 KV-5000	Direct connect to the CPU	RS232	Fig 1	Keyence KV series
KZ-300	Serial port module KZ-L2	RS232	Fig 2, fig 3	
		RS422	Fig 4	
KV-700	Serial port module KZ-L20	RS232	Fig 5, fig 6	
		RS422	Fig 7	

2.24.2 Parameters

HMI:

Parameters	Recommend settings	Choices of settings	Note
PLC type	Keyence KV series		
Port	RS232 port	RS232/RS422	
Data bit	8	7 or 8	
Stop bit	1	1 or 2	
Parity	Even parity	Even/odd/no parity	
Baud rate	9600	4800/38400/9600/115200/19200/187500	
Station no.	1	0~255	

The default parameters of Keyence KV series PLC: 9600, 8, 1, even parity, station no.1

2.24.3 Cable making

(a) CPU RS232 RJ-11:

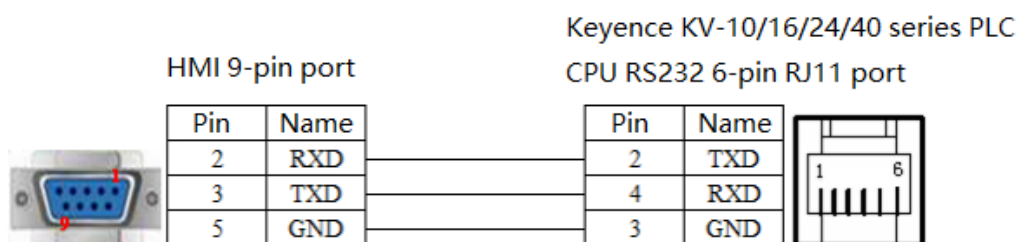

Fig1

(b) Serial port module KZ-L2(Port1, RS232)connects to Keyence KZ-300 PLC:

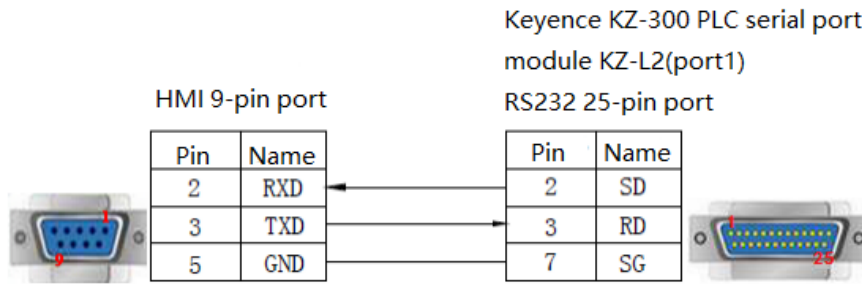

Fig2

(c) Serial port module KZ-L2(Port2, RS232)connects to Keyence KZ-300 PLC:

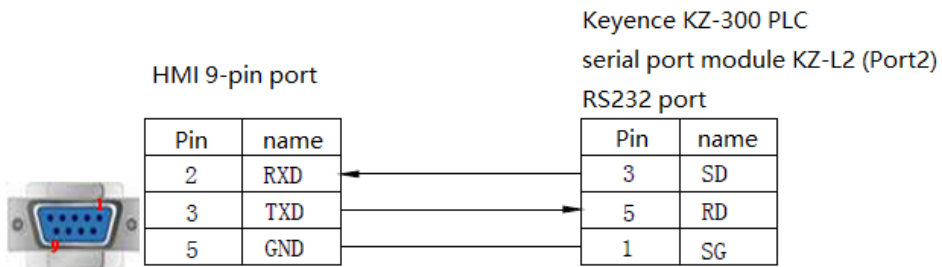

Fig3

(d) Serial port module KZ-L2(Port2, RS422)connects to Keyence KZ-300 PLC:

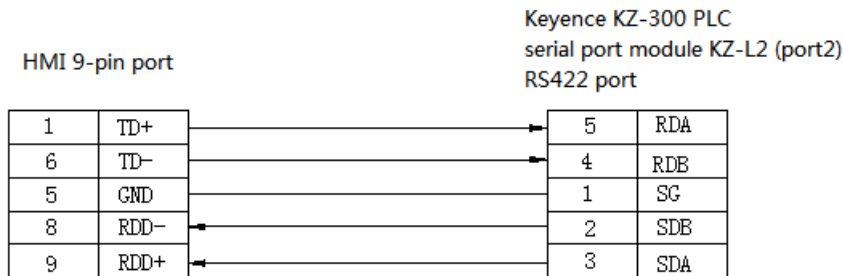

Fig4

(e) Serial port module KV-L20(Port1, RS232)connects to Keyence KV-700 PLC:

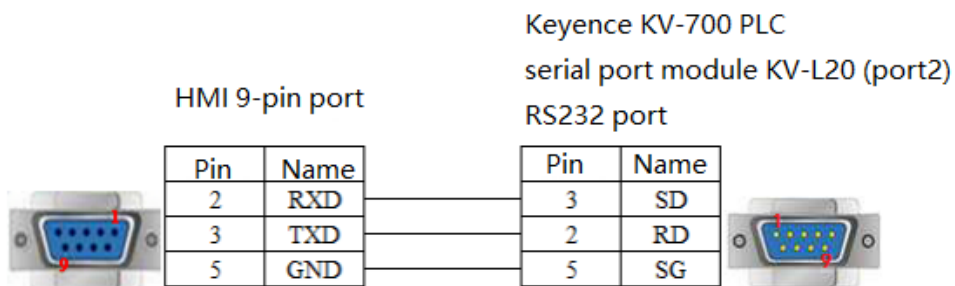

Fig5

(f) Serial port module KV-L20(Port2, RS232)connects to Keyence KV-700 PLC:

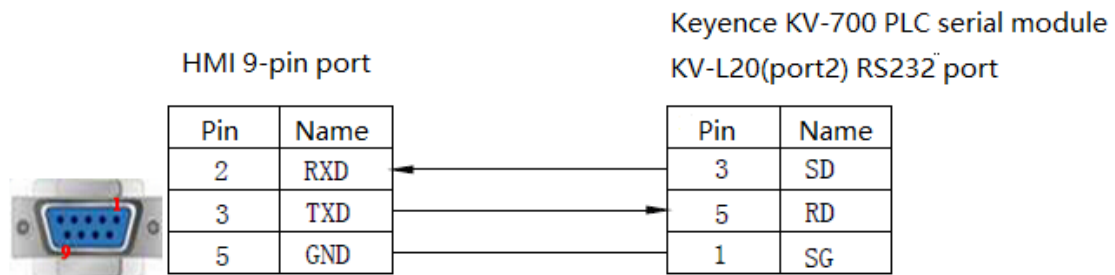

Fig6

(g) Serial port module KV-L20(Port2, RS422)connects to Keyence KV-700 PLC:

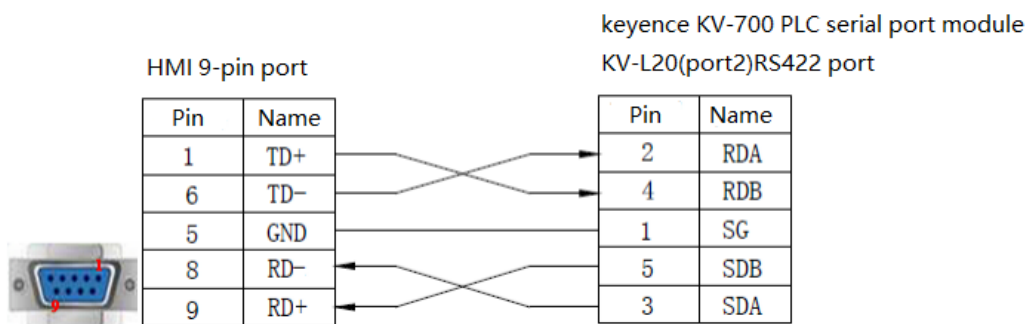

Fig7

2.24.4 Device address

PLC address	Range	Data type	Explanation
R	0.00~999.15	Bit	Input relay
	5.0~999.15	Bit	Output relay
MR	0.00~999.15	Bit	Internal relay
LR	0.00~999.15	Bit	
CR	0.00~39.15	Bit	
T	0~3999	Bit	Timer
C	0~3999	Bit	Counter
DM	0~65534	Word/DWord	Data register
TM	0~11998	Word	Temporary data storage
EM	0~511	Word	Extended data storage
FM	0~65534	Word	Flash data storage
CM	0~32766	Word	
TDC	0~3999	Word	
CDC	0~3999	Word	
TS	0~3999	Word	Timer
CS	0~3999	Word	counter

2.25 Keyence KV5000/5500/7500 (Ethernet) series PLC

2.25.1 Device type

Series	Port	Cable	PLC model in Touchwin software
Keyence KV5000 KV5500 KV7500	RJ45	Fig 1 or 2	Keyence KV5000/5500/7500

2.25.2 Parameter setting

Take Keyence KV5000 PLC as an example to explain the settings of communication device.

PLC software settings:

Startup KV STUDIO, click the unit edit, choose KV 5000, set the label in the unit, execute the Ethernet settings of KV5000, shown as below figure:

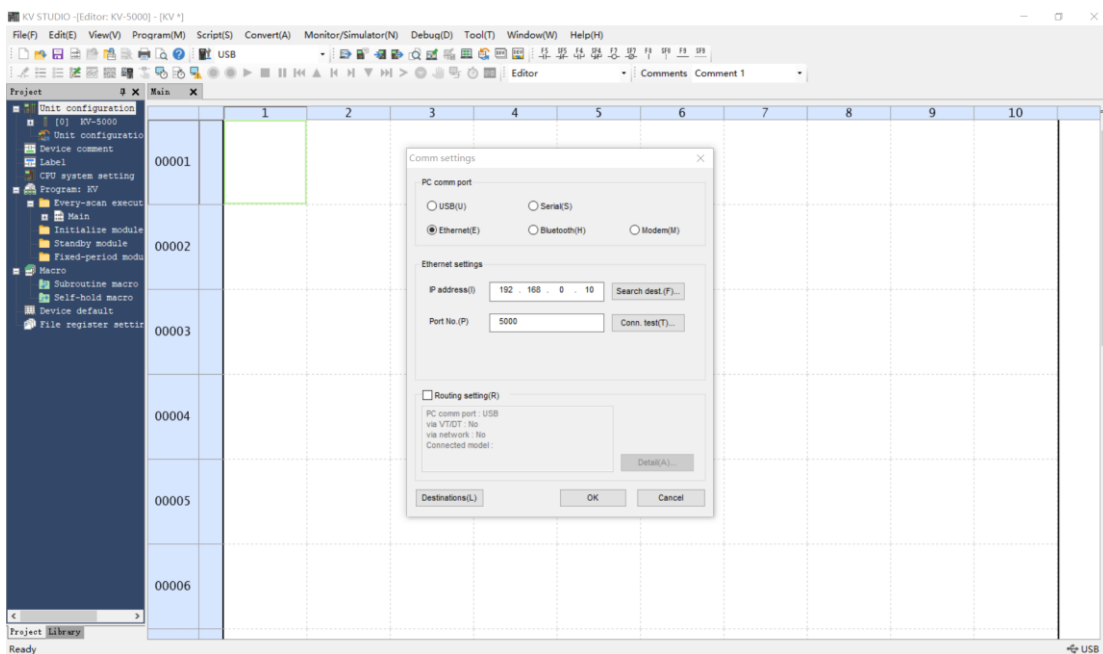

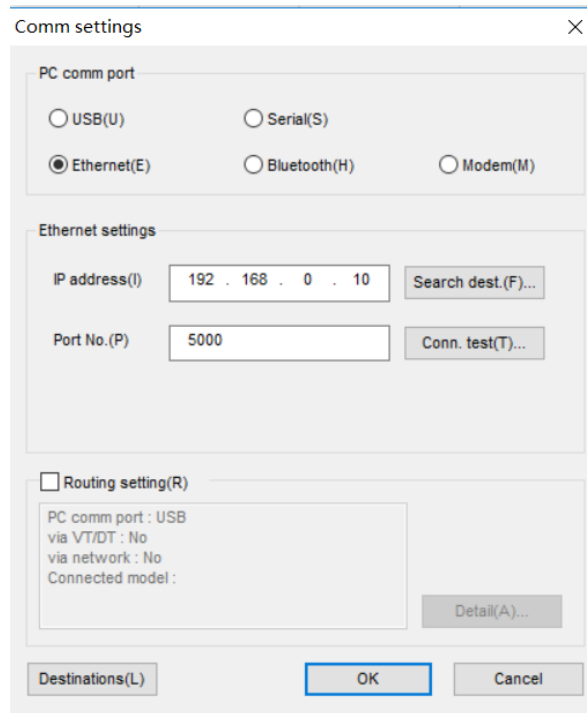

HMI settings:

1. choose HMI model TN(-ET), TG(-ET) or TE(-ET), click next, then choose net device, fill in the IP address of HMI. The HMI IP cannot be conflict with other devices in the network.
2. right click the net device, build a new project, and name it as Keyence KV5000.

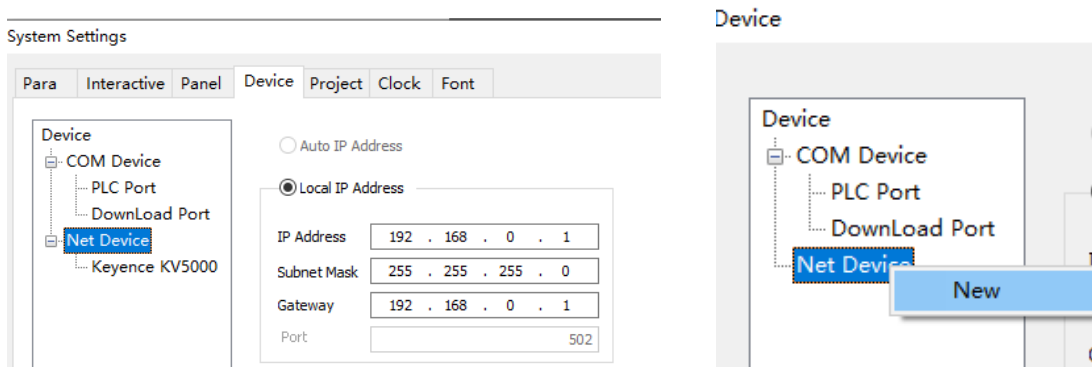

3. choose Keyence (KV5000/5500/7500) protocol in the list, and fill in the PLC IP address, the port is PLC port no. set in the PLC software.

System Settings

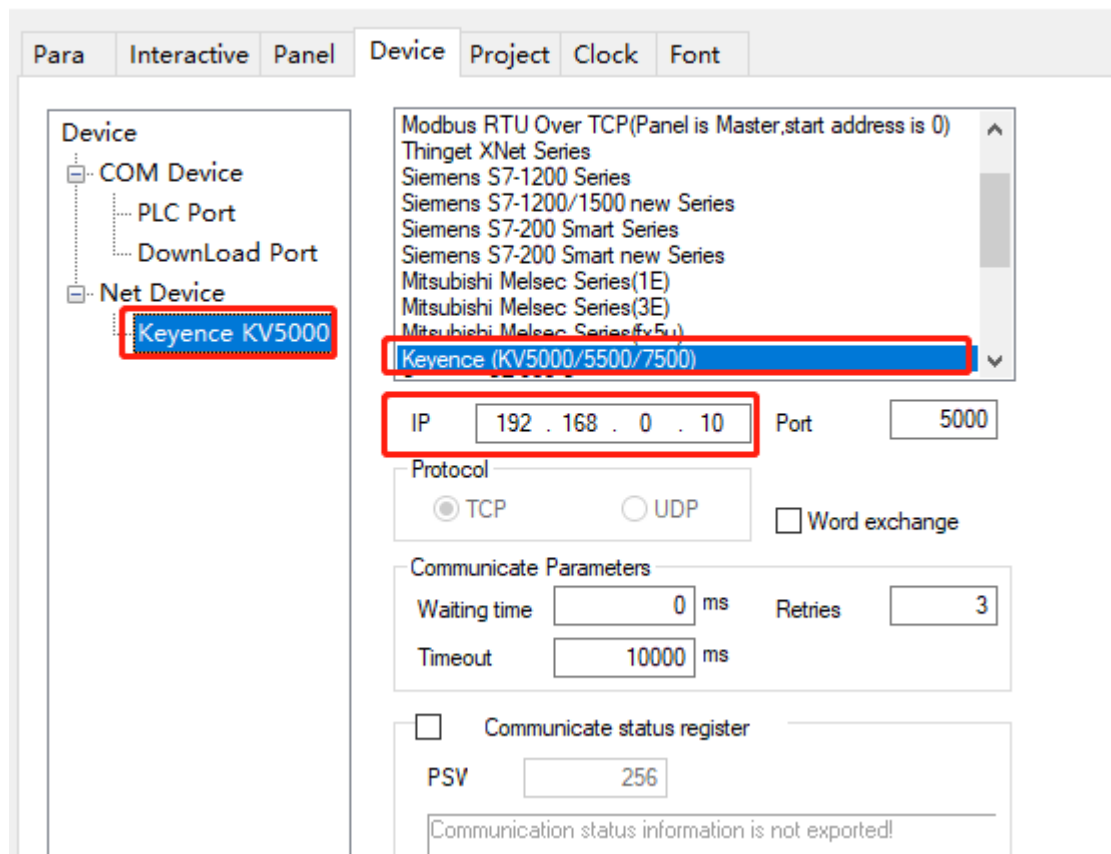

4. Please keep the communication parameters as default, if the communicate status register is selected, PSW256~PSW259 respectively indicate communication successful times, failed times, overtime times, error times. User can set the register address as needs.

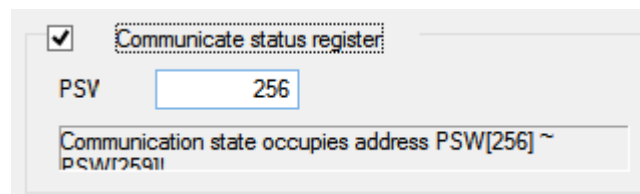

5. click next to finish the settings and enter screen edit interface. Put a data input button on the screen, and choose the keyence KV5000 in the device list.

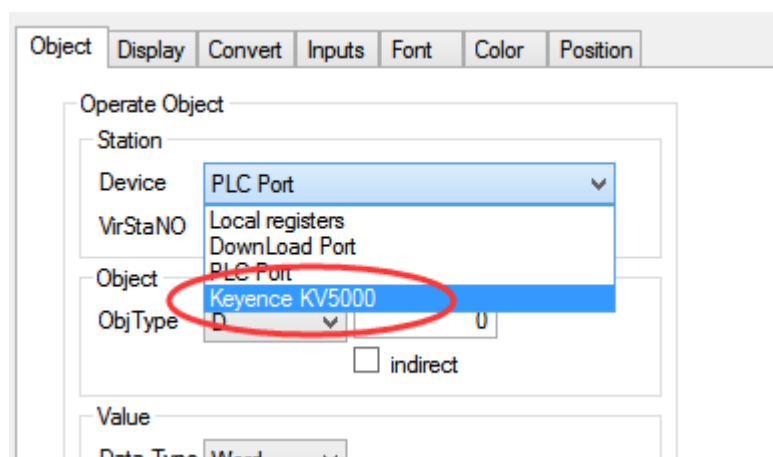

2.25.3 Cable making

RJ45 Straight Through Cable (connect HUB) or RJ45 Crossover Cable:

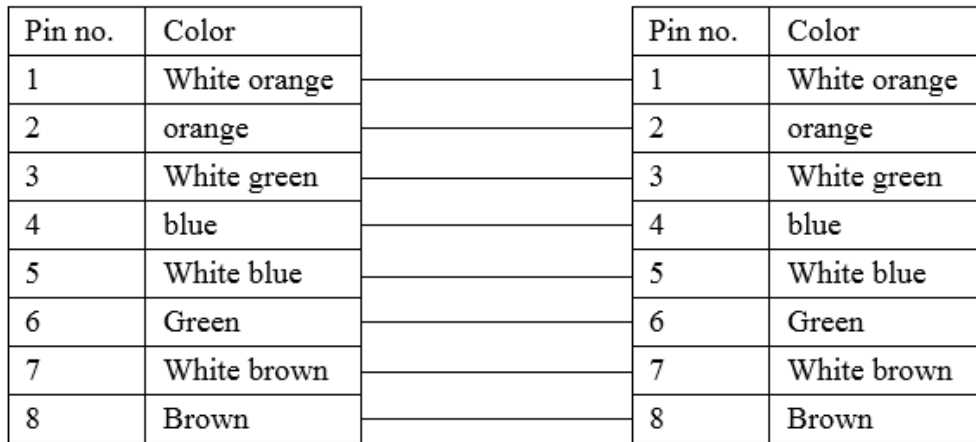

Fig 1

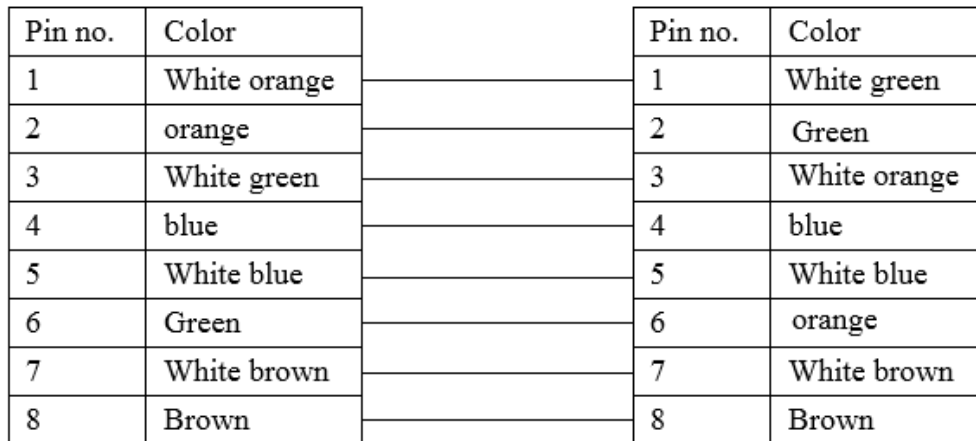

Fig 2

2.25.4 Device address

PLC address	Range	Object type	Notes
R	0.0~0.15	Bit	Input relay
R	5.0~5.07	Bit	Output relay
R	5.08~9.15 100.0~994.15	Bit	Internal relay
MR	0.00~999.15	Bit	Internal relay
LR	0.00~999.15	Bit	Latch register
CR	0.00~39.15	Bit	Control register
TS	0~3999	Bit(only read)	Timer
CS	0~3999	Bit(only read)	Counter
B	0~16383	Bit	Link relay
DM	0~32767	Word/DWord	Data register
EM	0~32767	Word	Expanded data memory

PLC address	Range	Object type	Notes
W	0~16383	Word	Link register
CM	0~15999	Word	Control memory
TN	0~3999	Word	Timer
CN	0~3999	Word	Counter
ZF	0~32767	Word	Flash data register
FM	0~32767	Word	Flash data register

2.26 Koyo Click series PLC

2.26.1 Device type

Koyo Direct Logic series DL05, DL250... (connect to CPU unit directly)

Series	CPU	Connected module	Port	Cable	PLC model in Touchwin software
Click		Connect to CPU RJ-11 port (RS232 port)	RS232	Fig 1	Koyo Click series

2.26.2 Parameter setting

1. HMI setting

Parameter	Recommended setting	Optional settings	Notes
PLC type	Koyo Click series		
Port type	RS232	RS232/RS422	
Data bit	8		
Stop bit	1		
Parity	Odd parity		
Baud rate	38400	9600/19200/38400	
Station no.	1	1~247	

Koyo Click series default communication parameters:

The screenshot shows a dialog box titled "Communicate parameters" with a close button (X) in the top right corner. The settings are as follows:

- Baud Rate:** Radio buttons for 4800, 56000, 9600, 57600, 19200, 115200, **38400** (selected), and 187500.
- Data bit:** Radio buttons for 7位 and **8位** (selected).
- Stop bit:** Radio buttons for **1位** (selected) and 2位.
- Checksum:** Radio buttons for No parity, **Odd** (selected), and Even.
- Delay:** A text input field for "Send delay time" with the value "0" and "ms" next to it.
- Send data:** A checked checkbox.
- Virtual Station:** An unchecked checkbox.
- Word exchange:** An unchecked checkbox.
- Retry Tim:** A text input field with the value "3".

At the bottom of the dialog are "OK" and "Cancel" buttons.

2. PLC setting

Please refer to Koyo S series PLC settings.

2.26.3 Cable making

RS232 wiring:

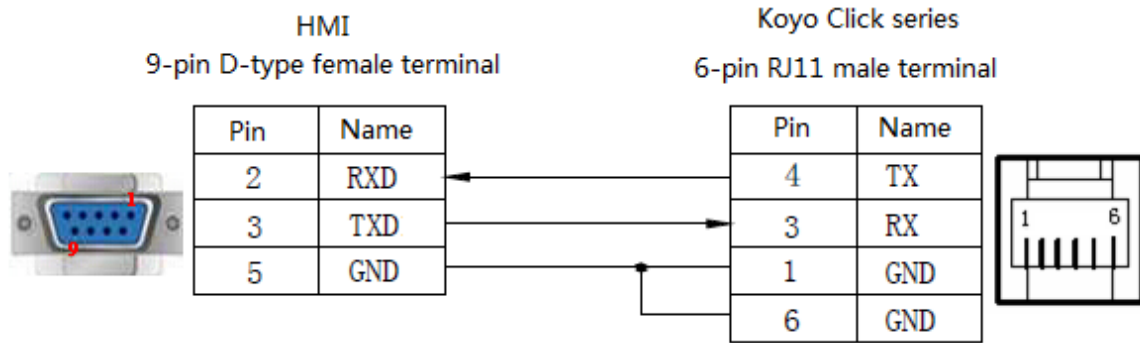

Fig1

2.26.4 Device address

Device type	Range	Object type	Explanation
X0	1~16	Bit	Input
X1	1~16	Bit	I/O module 1 input
X2	1~16	Bit	I/O module 2 input
Y0	1~16	Bit	Output
Y1	1~16	Bit	I/O module 1 output
Y2	1~16	Bit	I/O module 2 output
C	1~2000	Bit	Control bit
T	1~500	Bit	Timer
CT	1~250	Bit	Counter
SC	1~1000	Bit	System control bit
DS	1~4500	Word	Data temporary storage register, support double words
DD	1~1000	Word/DWord	Data temporary storage register, support double words
TD	1~500	Word	Timer present value
CTD	1~250	Word/DWord	Counter present value, support double words
SD	1~1000	Word	System data temporary storage register
DH	1~500	Word/DWord	Data temporary storage register
DF	1~500	DWord	Data temporary storage register (double words)
XD	0	Word/DWord	Input state temporary storage register
YD	0	Word/DWord	Input state temporary storage register
TXT	1~1000	Word/DWord	texts temporary storage register

2.27 Koyo Direct Logic (DL) series PLC

2.27.1 Device type

Koyo Direct Logic series DL05, DL250 PLC (direct connect to CPU)

Series	CPU	Connected module	Port	Cable	PLC model in Touchwin software
Direct Logic	DL05	Connect to CPU RJ-11 port	RS232	Fig 1	Koyo DL series
	DL105				
	DL230				
	DL240				
	DL250	Connect to CPU com port	RS422	Fig 2	
	DL350				
	DL430				
	DL440				
DL450					

Note: the port2 of DL250 has RS232 and RS422, please indentify the cable connection for them.

2.27.2 Parameters

HMI settings:

Parameters	Recommend settings	Choices of settings	Note
PLC type	Koyo DL series		
Port	RS232	RS232/RS422	
Data bit	8	7/8	
Stop bit	1	1/2	
Parity	Odd parity	Even /odd /no parity	
Baud rate	9600	4800/38400/9600/115200/19200/187500	
Station no.	0	0-255	

PLC settings:

Please refer to Koyo S series PLC .

2.27.3 Cable making

RS232 Connection:

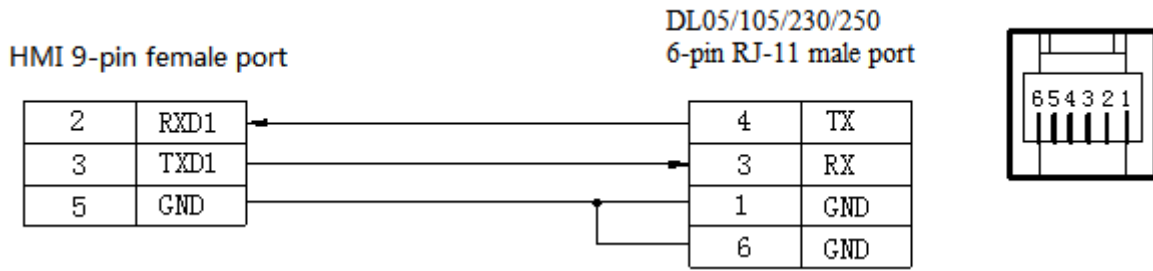

Fig1

RS422 connection:

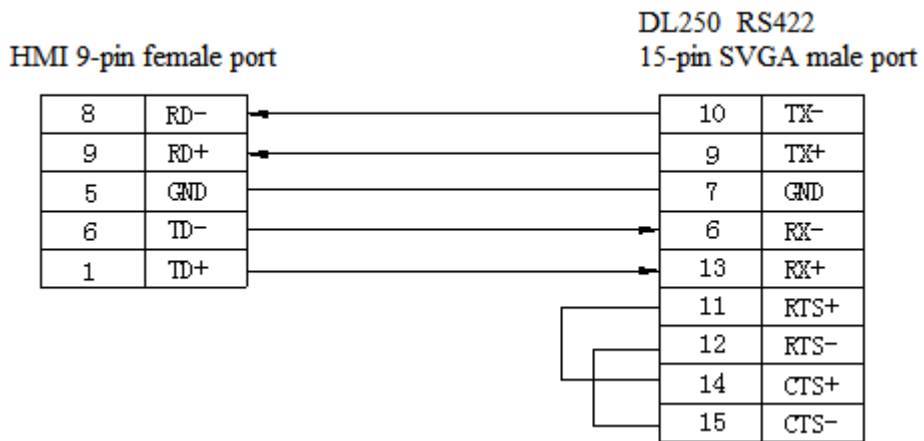

Fig2

2.27.4 Device address

Device address	Range	Data type	Explanation
V	0~41200	Word/DWord	Data register
C	0~777	Bit	Counter
X	0~777	Bit	Input
Y	0~777	Bit	Output
SP	0~777	Bit	Auxiliary relay
T	0~777	Bit	Timer
CT	0~777	Bit	Counter
S	0~777	Bit	Auxiliary relay
V	0.0~41200.15	Bit	Auxiliary relay

2.28 Koyo S series PLC

Koyo KOSTA-S and Direct-Logic series PLC

2.28.1 Device type

(a) Kostac S series SH/SM/SN PLC (direct connect to the CPU module)

Series	CPU	Connected module	Port	Cable	PLC model in Touchwin software
SH series	SH-48RS	CPU	RS232	Fig1	Koyo S series
SM series	SM24-T SM-16R SM1				
SN series					

Note: Koyo SH-48RS doesn't have Run, Stop switch, but only have one AMP port.

(b) Koyo Kostac S series SG-8, SU-5, SU-6, SR-21, SR-22... PLC (use communication module)

Series	CPU	Connected module	Port	Cable	Device
SG series	SG-8	G01-DM communication unit	RS232	Fig 2	Koyo S series
			RS422	Fig 3	
SU series	SU-5	U01-DM communication unit	RS232	Fig 2	
	SU-6	U01-DM communication unit			
	SU-6B	U01-DM communication unit			
SR series	SR-21	E-02DM-R1 communication unit	RS422	Fig 3	

2.28.2 Parameters

HMI:

Parameter	Recommend settings	Choices of settings	Notes
PLC	Koyo S series PLC		
Port	RS232	RS232 or RS422	
Data bit	8	7 or 8	
Stop bit	1	1 or 2	
Parity	Odd parity	Even/odd/no parity	
Baud rate	9600	4800/38400/9600/115200/19200/187500	
Station no.	0	0~255	

The default communication parameters of Koyo S series PLC: 9600, 8, 1, odd parity, station no.0.

PLC:

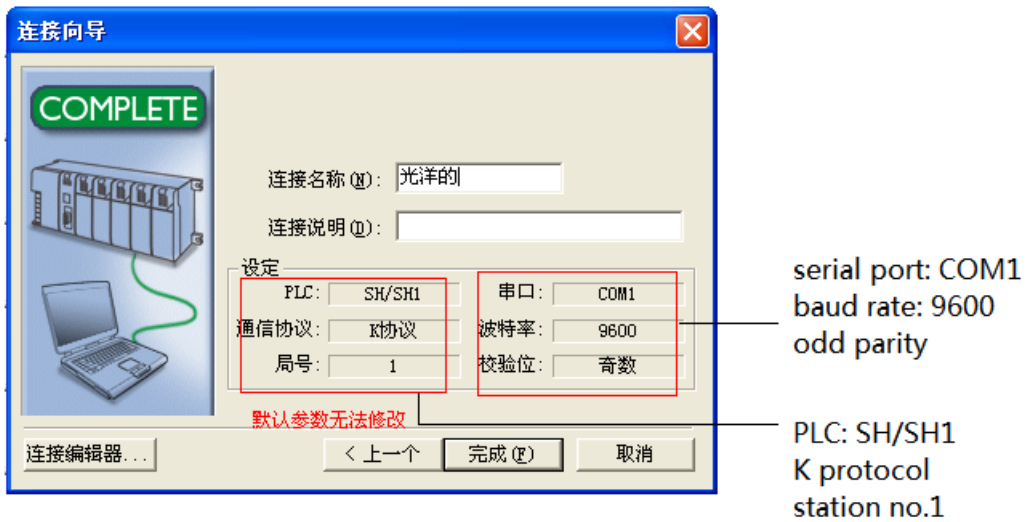
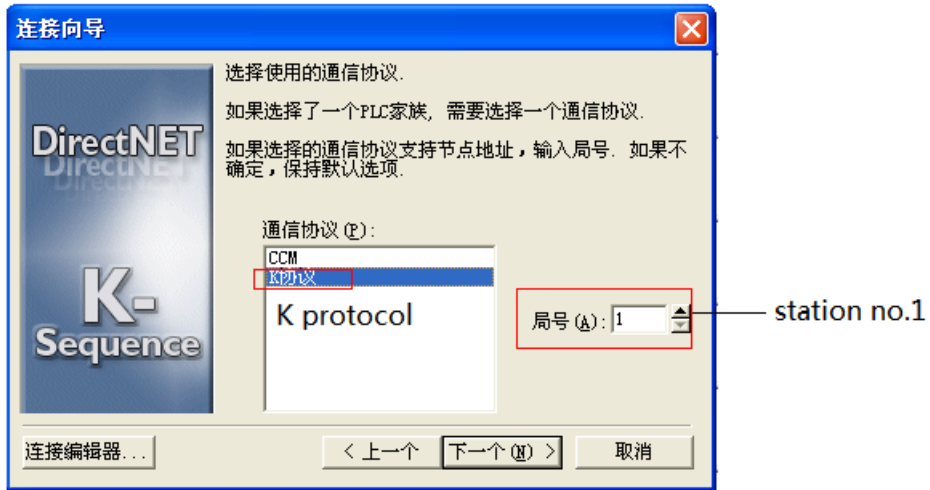

- Note: 1. Koyo K protocol cannot modify station no., the station no. is 0 in the HMI.
 2. The register address starts from R2000.
 3. The security password function must be cancelled.
 4. CPU unit with working mode setting switch must set the switch to term state.

2.28.3 Cable making

(a) RS232 25-pin port on CPU or communication unit:

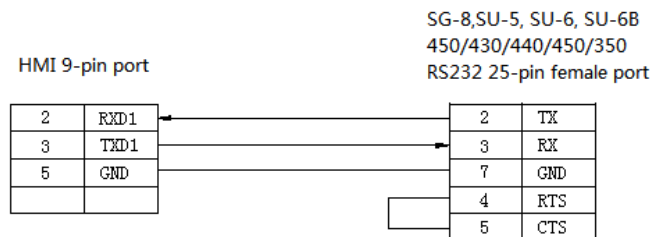

Fig1

RJ-11 6-pin RS232 female port on the CPU:

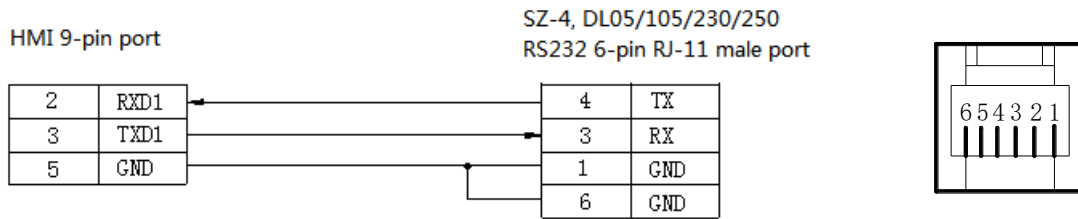

Fig2

RS422 connection:

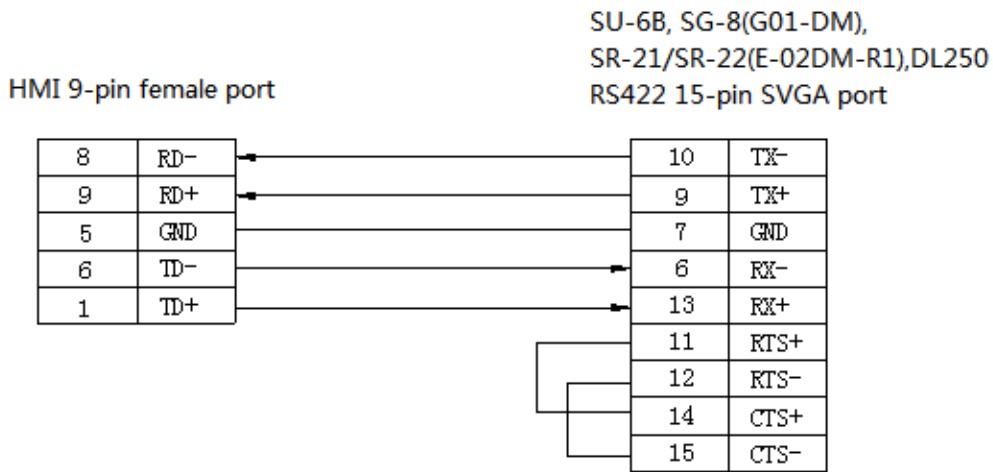

Fig3

2.28.4 Device address

PLC address	Range	Data type	Explanation
M	0~777	Bit	Internal auxiliary coil
I	0~777	Bit	External input coil
Q	0~777	Bit	External output coil
SP	0~777	Bit	Internal auxiliary coil
T	0~777	Bit	Timer
C	0~777	Bit	Counter
S	0~777	Bit	Stepper coil
R	0~41200	Word/DWord	Data register

2.29 LG Master-K series PLC

LG Master-K series PLC support CPU(RS232) and CNet module communication mode. This chapter will introduce CPU mode.

2.29.1 Device type

Series	Connected module	Port	Cable	PLC model in Touchwin software
K80 K120 K200-K3P-07AS	CPU RS232 port	RS232	Fig 1	LS Master-K CPU Direct
	CNet communication module	RS232	Fig 2	LS Master-K CNet
		RS485	Fig 3	

2.29.2 Parameters

1. Programming port communication

HMI:

Parameters	Recommend settings	Choices of settings	Notes
PLC type	LG Master-K80/120 series PLC		
Port	RS232	RS232	
Dat bit	8	7 or 8	
Stop bit	1	1 or 2	
Parity	No parity	Even/odd/no parity	
Baud rate	38400	4800/38400/9600/115200/19200/187500	
Station no.	0	0~255	

The default communication parameters of LG Master K: 38400, 8, 1, no parity, station no.0.

PLC:





Note:

before communicating, please write “END” instruction to the PLC. Otherwise, the PLC will report an error and the ERR LED will light.

2.CNET port communication

HMI:

Parameters	Recommend settings	Choices of settings	Notes
PLC type	LG Master-K80/120 series PLC(CNet)		
Port	RS232	RS232	
Dat bit	8	7 or 8	
Stop bit	1	1 or 2	
Parity	Even parity	Even/odd/no parity	
Baud rate	9600	9600/19200/38400	
Station no.	1	0~31	

PLC:

(a) RS232



(b) RS485



Notes:

- (1) Set the build-in CNET switch of PLC body to the on state.
- (2) Select the correct channel and set the correct communication channel, protocol and mode.
- (3) Before PLC communication, write an end command to PLC, otherwise PLC will give an error and err will be on.

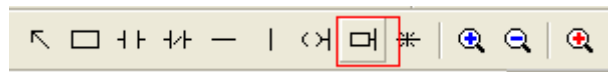

2.29.3 Cable making

Master-K 80/120 RS232:

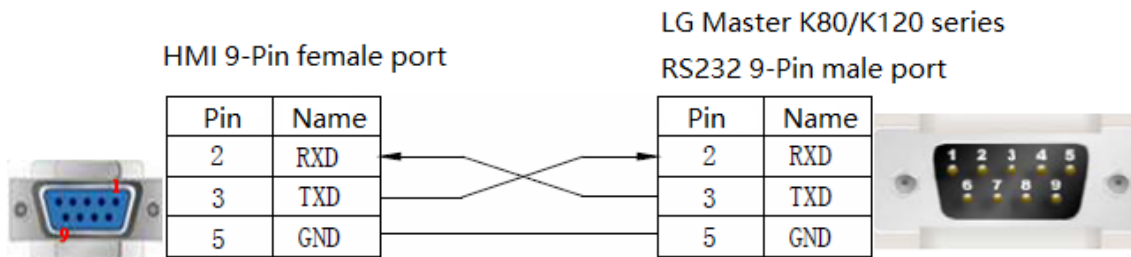

Fig1

Master K-CNet RS232:

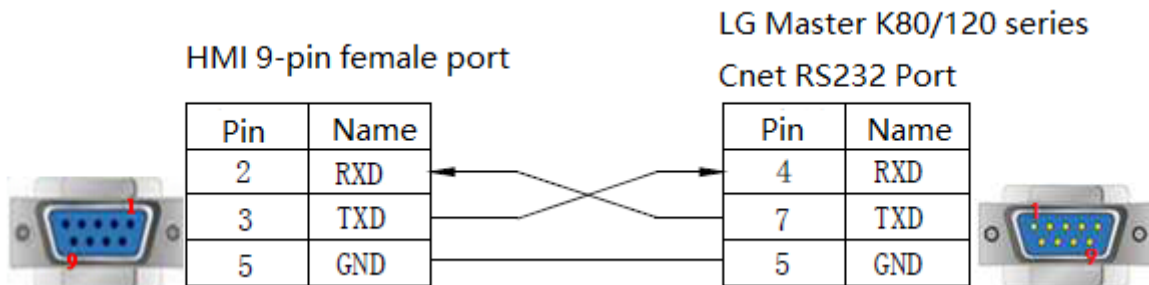

Fig 2

Master K-CNet RS485:

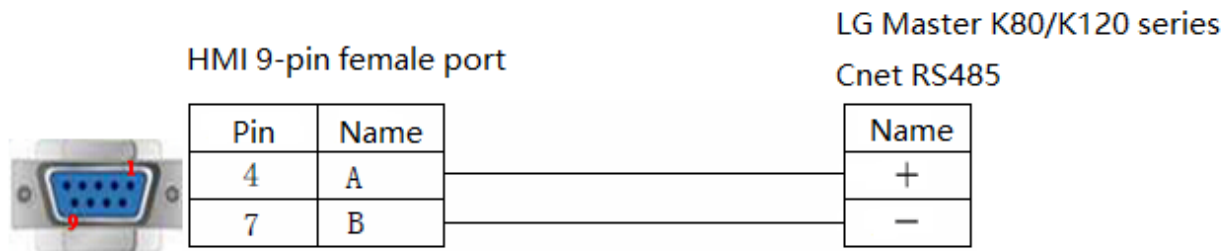

Fig 3

2.29.4 Device address

LGMaster-K80/120 series PLC

PLC address	Range	Data type	Explanation
M	0~9999F	Bit	Internal auxiliary relay
L	0~9999F	Bit	Link relay
K	0~9999F	Bit	Holding relay
T	0~9999	Bit	Timer
C	0~9999	Bit	Counter
P	0~9999F	Bit	I/O coil
D	0~9999	Word/DWord	Data register
TD/T	0~9999	Word/DWord	Timer
CD/C	0~9999	Word/DWord	Counter
S	0~9999	Word/DWord	Used as register
K	0~9999	Word/DWord	Used as register
M	0~9999	Word/DWord	Used as register
L	0~9999	Word/DWord	Used as register
F	0~9999	Word/DWord	Used as register
P	0~9999	Word/DWord	Used as register

2.30 LG Glofa(Cnet) series PLC

2.30.1 Device type

Series	CPU	Connected module	Port	Cable	PLC model in Touchwin software
Glofa	G7M-DR20A	CPU RS232	RS232	Fig 1	LS Glofa(Cnet)series

Note: please turn on DIP switch2 and turn off switch1 for LG Glofa -cnet communication.

2.30.2 Parameters

HMI:

Parameters	Recommend settings	Choices of settings	Note
PLC type	LG Glofa (cnet)		
Port	RS232	RS232	
Data bit	8	7 or 8	
Stop bit	1	1 or 2	
Parity	No parity	Even/odd/no parity	
Baud rate	19200	4800/38400/9600/115200/19200/187500	
Station no.	0	0~255	

The default parameters of LG Glofa –Cnet: 19200, 8, 1, no parity, station no.0.

PLC:

Note:

1. Turn on the switch BUILT-IN CNET on the PLC.
2. “Dedicated-slave” must be choosed in the PLC programming software.
3. The communication area of M must be set in the PLC programming software.

M area size:

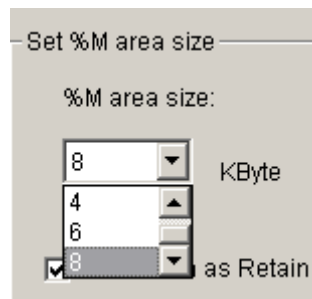

Protocol and mode settings:

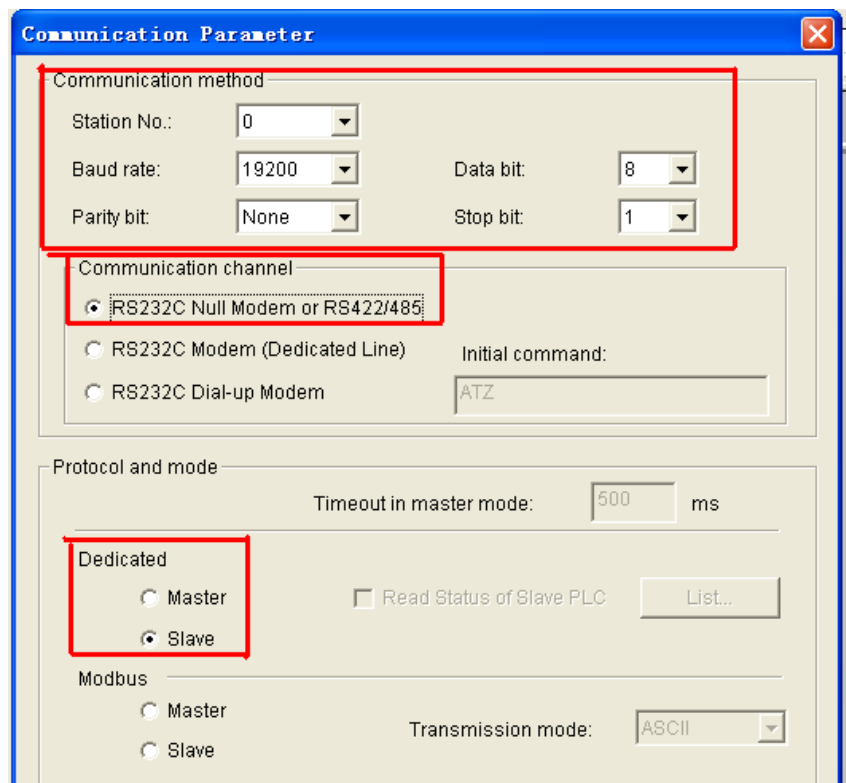
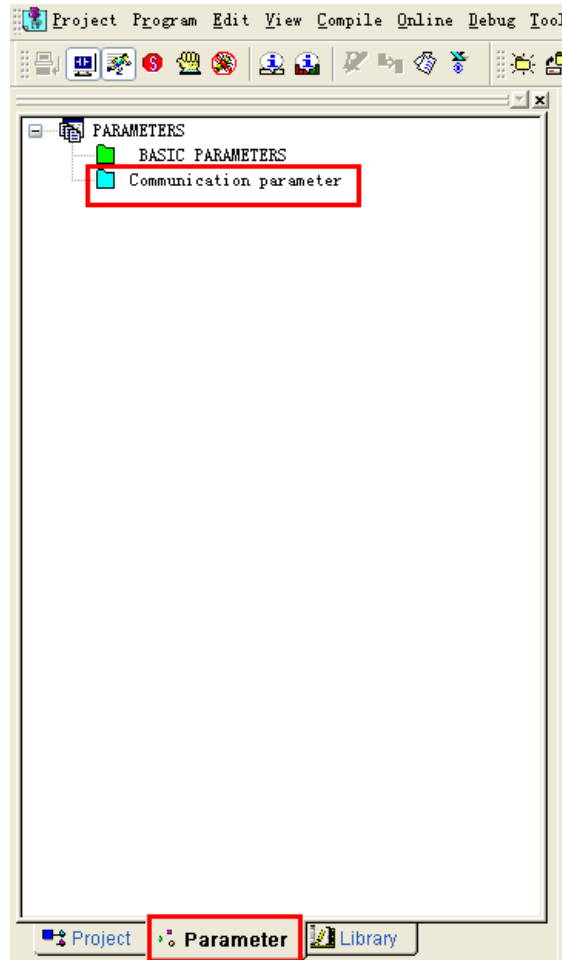

2.30.3 Cable making

LG Glofa –Cnet RS232:

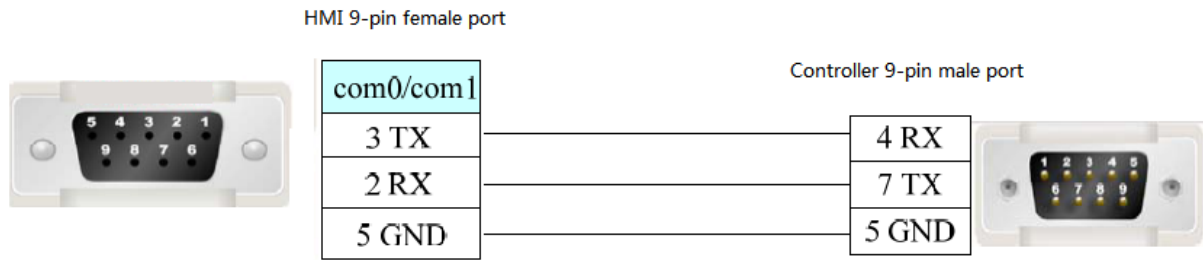

Fig 1

2.30.4 Device address

PLC type	Range	Data type	Explanation
M	0~16383	Bit	Internal auxiliary relay
IX	0.0.0~0.0.11	Bit	External input coil
	0.0.12~0.0.63	Bit	Internal auxiliary input coil
	0.1.0~0.1.63	Bit	Internal auxiliary input coil
	0.2.0~0.2.63	Bit	Internal auxiliary input coil
	0.3.0~0.3.63	Bit	Internal auxiliary input coil
	0.4.0~0.4.63	Bit	Internal auxiliary input coil
	0.5.0~0.5.63	Bit	Internal auxiliary input coil
	0.6.0~0.6.63	Bit	Internal auxiliary input coil
	0.7.0~0.7.63	Bit	Internal auxiliary input coil
QX	0.0.0~0.0.11	Bit	External output coil
	0.0.12~0.0.63	Bit	Internal auxiliary output coil
	0.1.0~0.1.63	Bit	Internal auxiliary output coil
	0.2.0~0.2.63	Bit	Internal auxiliary output coil
	0.3.0~0.3.63	Bit	Internal auxiliary output coil
	0.4.0~0.4.63	Bit	Internal auxiliary output coil
	0.5.0~0.5.63	Bit	Internal auxiliary output coil
	0.6.0~0.6.63	Bit	Internal auxiliary output coil
	0.7.0~0.7.63	Bit	Internal auxiliary output coil
IW	0.0.0~0.0.3	Word/DWord	Data register
	0.1.0~0.1.3	Word/DWord	Data register
	0.2.0~0.2.3	Word/DWord	Data register
	0.3.0~0.3.3	Word/DWord	Data register
	0.4.0~0.4.3	Word/DWord	Data register
	0.5.0~0.5.3	Word/DWord	Data register
	0.6.0~0.6.3	Word/DWord	Data register
	0.7.0~0.7.3	Word/DWord	Data register

QW	0.0.0~0.0.3	Word/DWord	Data register
	0.1.0~0.1.3	Word/DWord	Data register
	0.2.0~0.2.3	Word/DWord	Data register
	0.3.0~0.3.3	Word/DWord	Data register
	0.4.0~0.4.3	Word/DWord	Data register
	0.5.0~0.5.3	Word/DWord	Data register
	0.6.0~0.6.3	Word/DWord	Data register
	0.7.0~0.7.3	Word/DWord	Data register
MW	0~4095	Word	Data register
	0~4095	Regs	Data register
MD	0~2047	DWord	Data register
	0~2038	Regs	Data register

2.31 LG XGB(CPU Direct) series PLC

2.31.1 Device type

Series	CPU	Connected module	Port	Cable	PLC model in Touchwin software
XGB	XBC-DR20E	Programming port	RS232	Fig1	LG XGT/XGK/XGB CPU Direct
	XBC-DR30E	CNet port	RS232	Fig2	LG Master-K CNet
	RS485		Fig3		

2.31.2 Parameters

1.Programming port communication

HMI:

Parameters	Recommend settings	Choices of settings	Note
PLC type	LG XGT/XGK series(CPU Direct)		
Port	RS232		
Data bit	8		
Stop bit	1		
Parity	No parity		
Baud rate	115200		
Station no.	0		

Note:XGB series (CPU direct) only supports 115200 baud rate, and the station number cannot be modified.

2.CNET port communication

HMI:

Parameters	Recommend settings	Choices of settings	Note
PLC type	LG Master-K80/120 series(CNet)		
Port	RS232	RS232/RS485	
Data bit	8		
Stop bit	1		
Parity	No parity		
Baud rate	9600	9600/19200/38400	
Station no.	1	0~31	

PLC settings:

(a) RS232

Tools network manager set communication parameters:

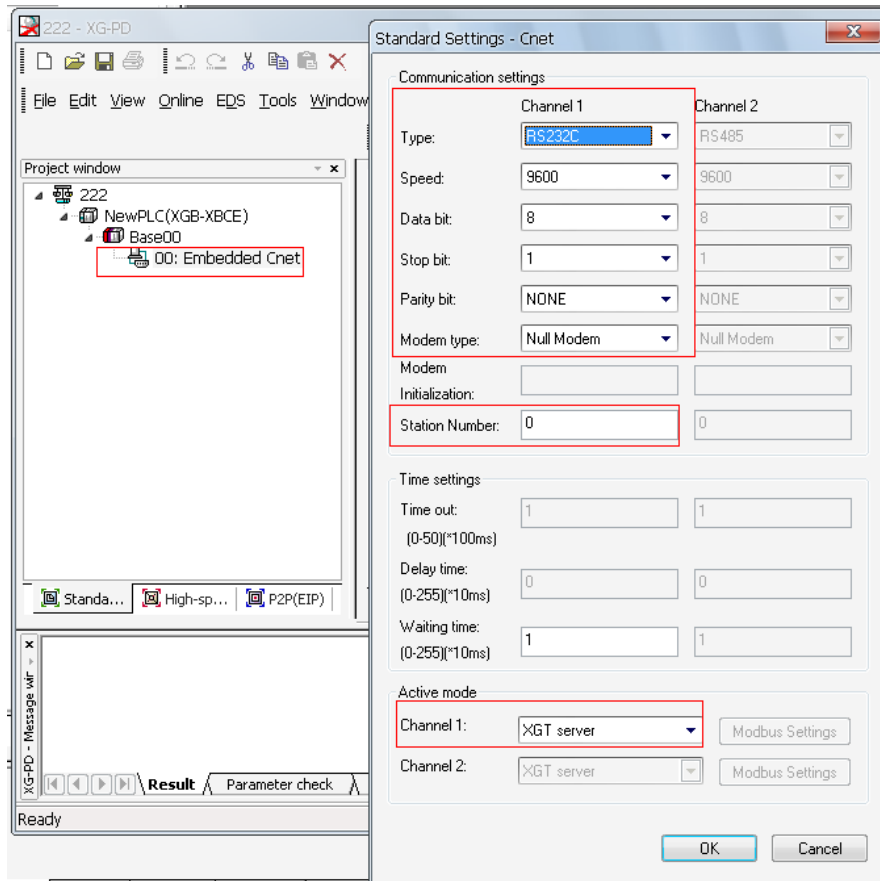
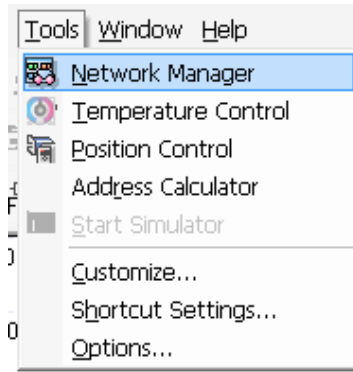

(b) RS485

Tools network manager set communication parameters:

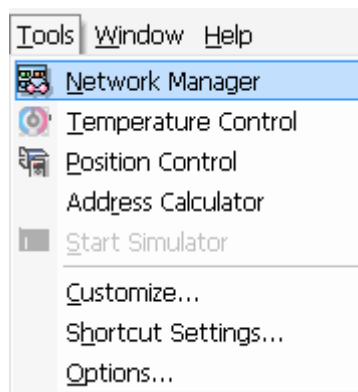

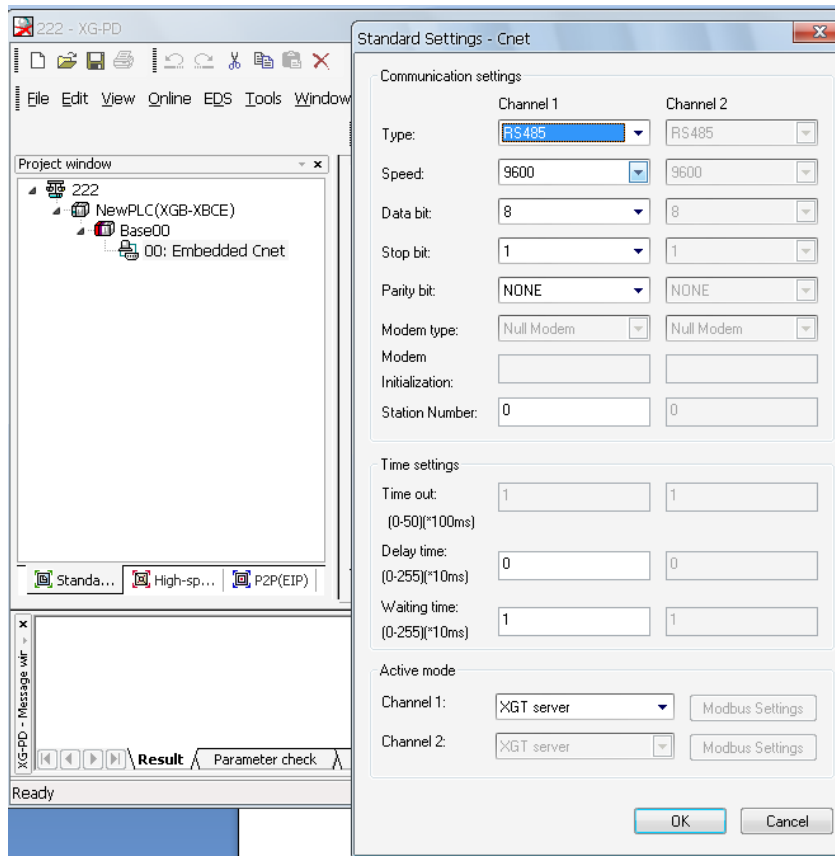

2.31.3 Cable making

RS232 port

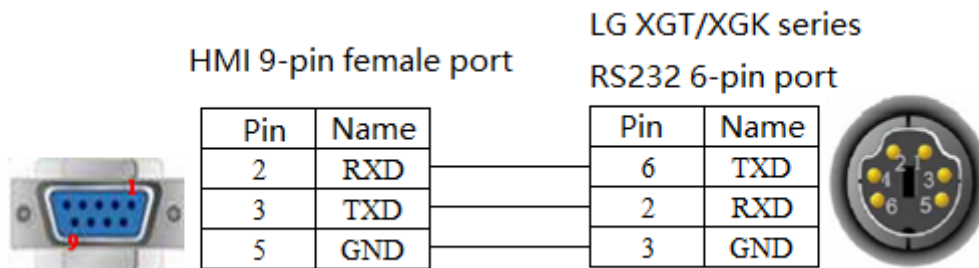

Fig 1

Cnet RS232 port

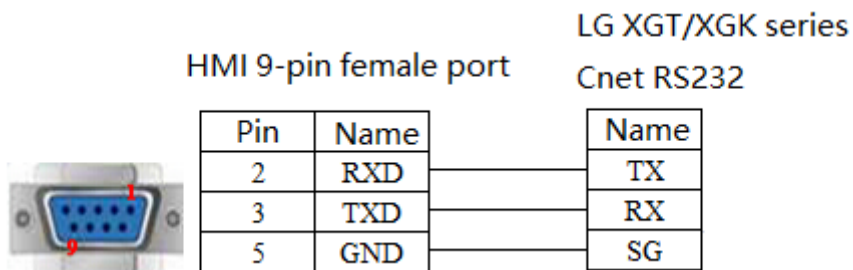

Fig 2

Cnet RS485 port

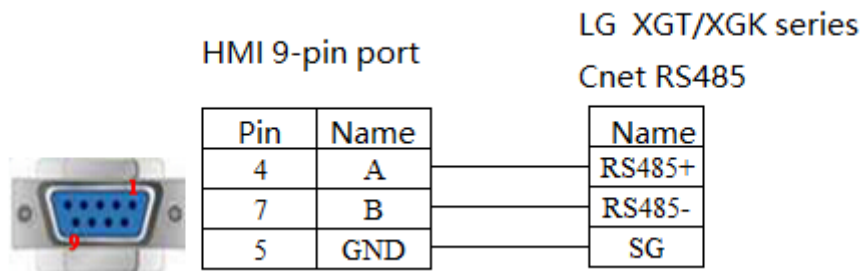

Fig3

2.31.4 Device address

PLC address	Range	Data type	Explanation
P	0.0~65535.F	Bit	External I/O coil
	65535	Word/DWord	Data register
M	0.0~65535.F	Bit	Internal auxiliary output coil
	65535	Word/DWord	Data register
L	0.0~65535.F	Bit	External output coil
	65535	Word/DWord	Data register
F	0.0~65535.F	Bit	Data register
	65535	Word/DWord	Data register
T	65535	Word/DWord	Data register
	65535	Bit	Counter
C	65535	Word/DWord	Data register
	65535	Bit	Counter
D	65535	Word/DWord	Data register
	0.0~65535.F	Bit	Relay
S	65535	Bit	Relay
K	65535	Word/DWord	Data register
	0.0~65535.F	Bit	Relay
Z	65535	Word/DWord	Data register
	0.0~65535.F	Bit	Relay
N	65535	Word/DWord	Data register
	0.0~65535.F	Bit	Relay
R	65535	Word/DWord	Data register
	0.0~65535.F	Bit	Relay
ZR	65535	Word/DWord	Data register
	0.0~65535.F	Bit	Relay
TS	65535	Word	Data register
CS	65535	DWord	Data register

2.32 LG XGT/XGK(CPU Direct) series PLC

2.32.1 Device type

Series	CPU	Connected module	Port	Cable	PLC model in Touchwin software
XGT		CPU RS232	RS232	Fig 1	LG XGT/XGK/XGB CPU Direct
XGK	XGK-CPUS				

2.32.2 Parameters

HMI:

Parameter	Recommend settings	Choices of settings	Note
PLC type	LG XGT/XGK/XGB series(CPU Direct)		
Port	RS232	RS232	
Data bit	8	7 or 8	
Stop bit	1	1 or 2	
Parity	No parity	Even/odd/no parity	
Baud rate	115200	4800/38400/9600/115200/19200/187500	
Station no.	1	0~255	

The default parameters of LG XGT series PLC(CPU Direct): 115200, 8, 1, no parity, station no.1

Note: XGT series(CPU Direct)only supports the baud rate 115200 and cannot modify the station no.

2.32.3 Cable making

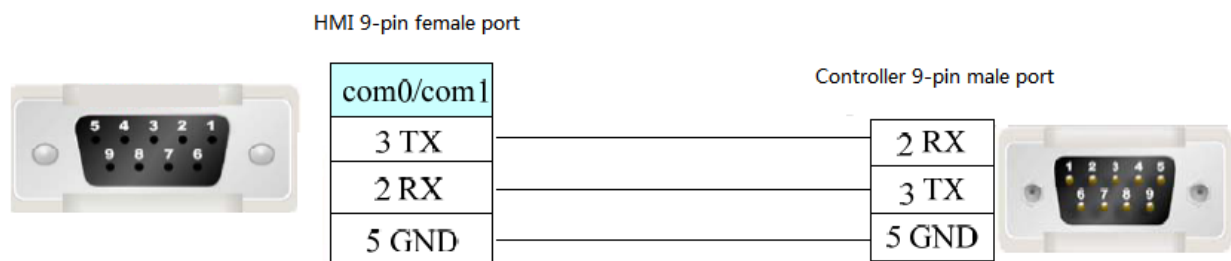

Fig1

2.32.4 Device address

PLC address	Range	Data type	Explanation
P	0.0~65535.F	Bit	External I/O coil
	65535	Word/DWord	Data register
M	0.0~65535.F	Bit	Internal auxiliary output coil
	65535	Word/DWord	Data register
L	0.0~65535.F	Bit	External output coil
	65535	Word/DWord	Data register
F	0.0~65535.F	Bit	Data register
	65535	Word/DWord	Data register
T	65535	Word/DWord	Data register
	65535	Bit	Counter
C	65535	Word/DWord	Data register
	65535	Bit	Counter
D	65535	Word/DWord	Data register
	0.0~65535.F	Bit	Relay
S	65535	Bit	Relay
K	65535	Word/DWord	Data register
	0.0~65535.F	Bit	Relay
Z	65535	Word/DWord	Data register
	0.0~65535.F	Bit	Relay
N	65535	Word/DWord	Data register
	0.0~65535.F	Bit	Relay
R	65535	Word/DWord	Data register
	0.0~65535.F	Bit	Relay
ZR	65535	Word/DWord	Data register
	0.0~65535.F	Bit	Relay
TS	65535	Word	Data register
CS	65535	DWord	Data register

2.33 LG XGT(Ethernet) series PLC

2.33.1 Device type

Series name	Communication type	Cable making	PLC model in Touchwin software
LG XGT series	RJ45	Fig 1 or 2	LG XGT protocol

2.33.2 Parameter setting

Take LG XGT series PLC as an example to explain the communication settings.

PLC settings:

Open the PLC software, set the PLC IP to 192.168.6.10 for example.

HMI settings:

1. choose HMI model TN(-ET), TG(-ET) or TE(-ET), click next, then choose net device, fill in the IP address of HMI. The HMI IP cannot be conflict with other devices in the network. The HMI IP is set to 192.168.6.11 for example.

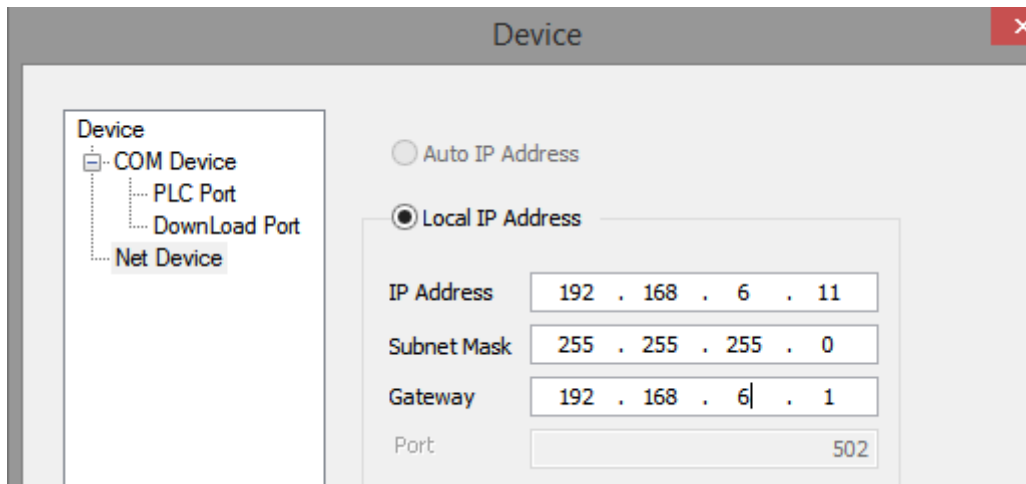

2. right click the net device, build a new project, and name it as LG XGT.

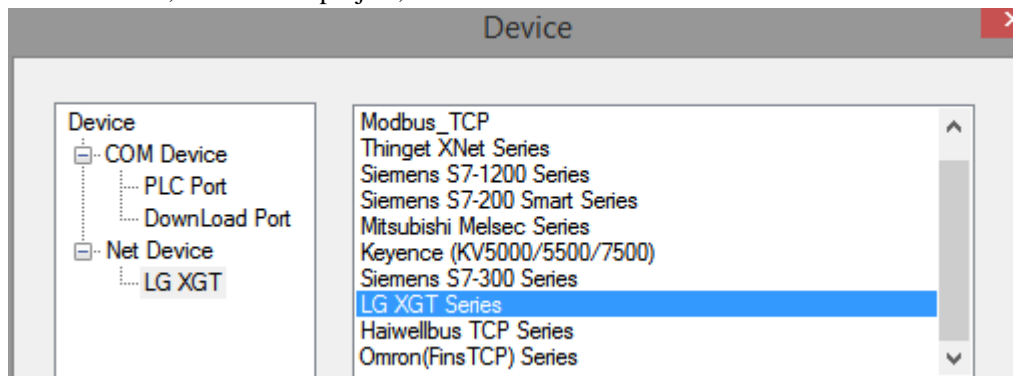

3. choose LG XGT series protocol in the list, and fill in the PLC IP address, the port is PLC port no. set in the

PLC software.

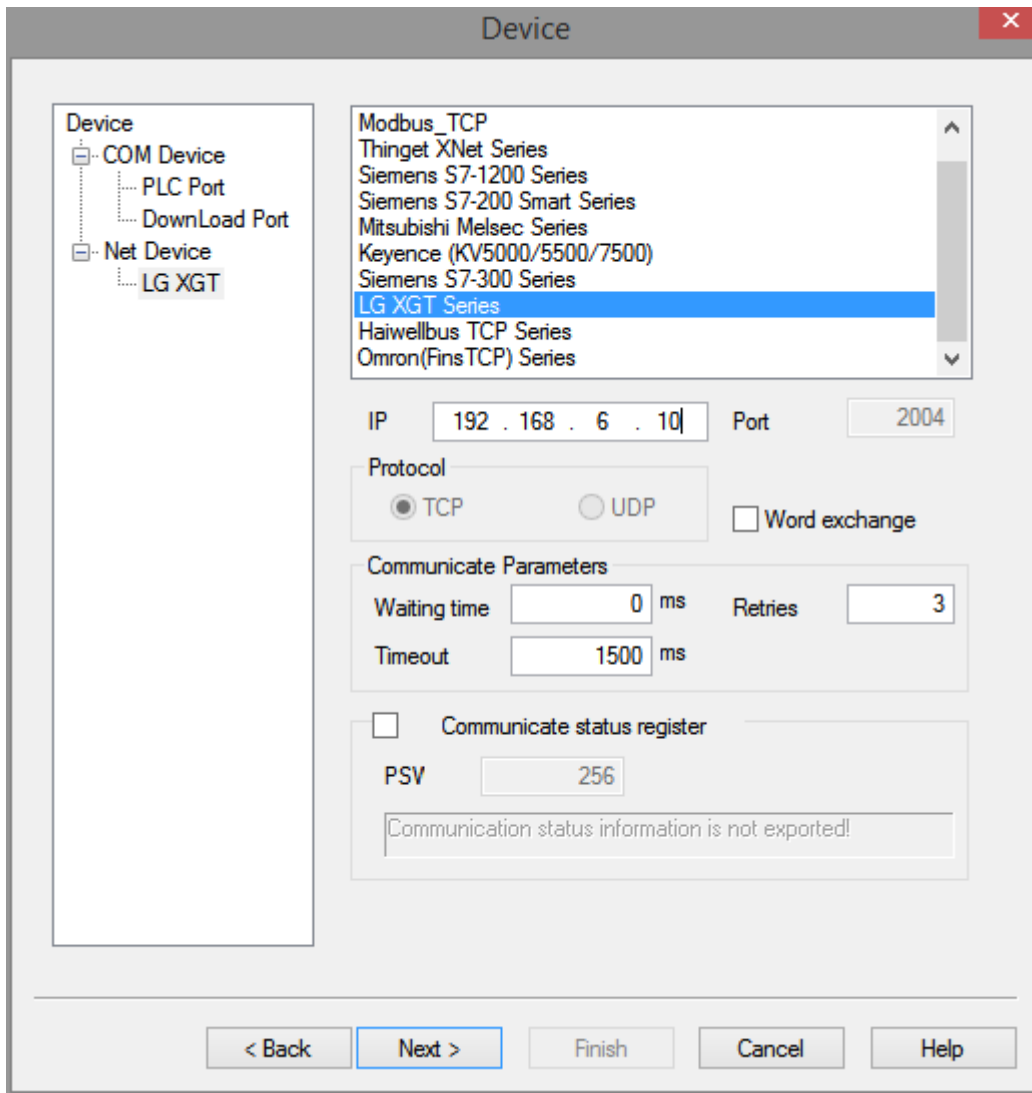

4. Please keep the communication parameters as default, if the communicate status register is selected, PSW256~PSW259 respectively indicate communication successful times, failed times, overtime times, error times. User can set the register address as needs.

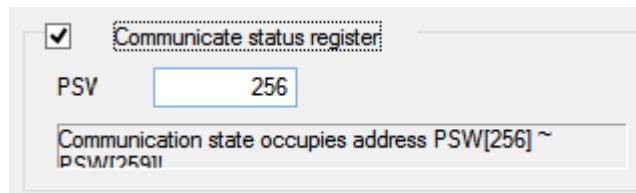

5. click next to finish the settings and enter screen edit interface. Put a data input button on the screen, and choose the LG XGT in the device list.

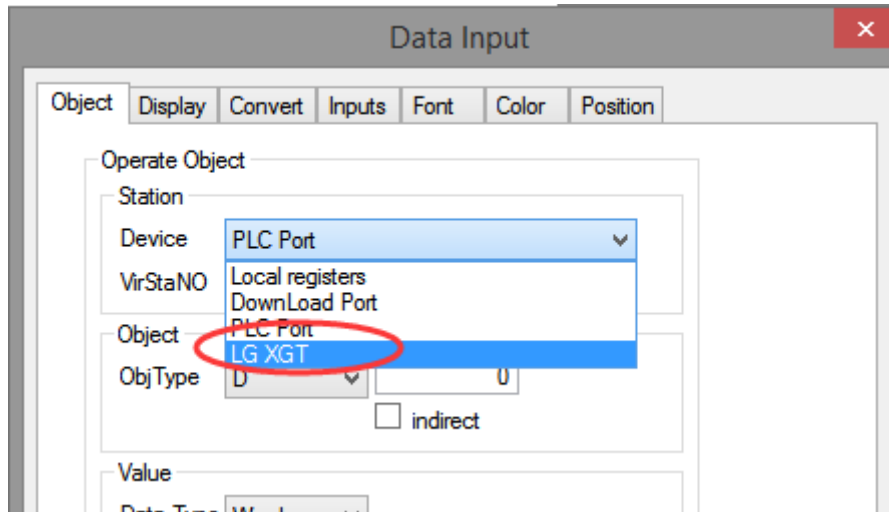

2.33.3 Cable making

RJ45 Straight Through Cable (connect HUB) or RJ45 Crossover Cable:

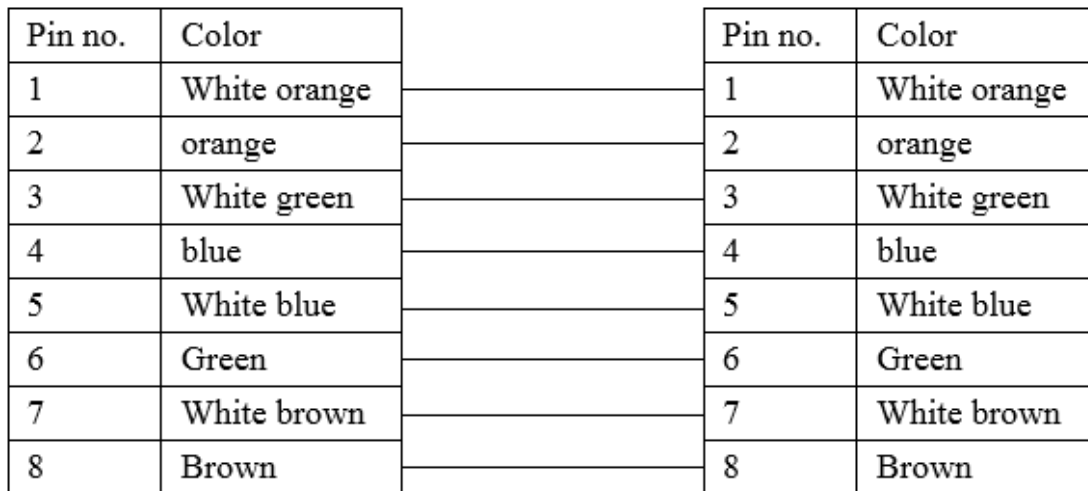

Fig 1

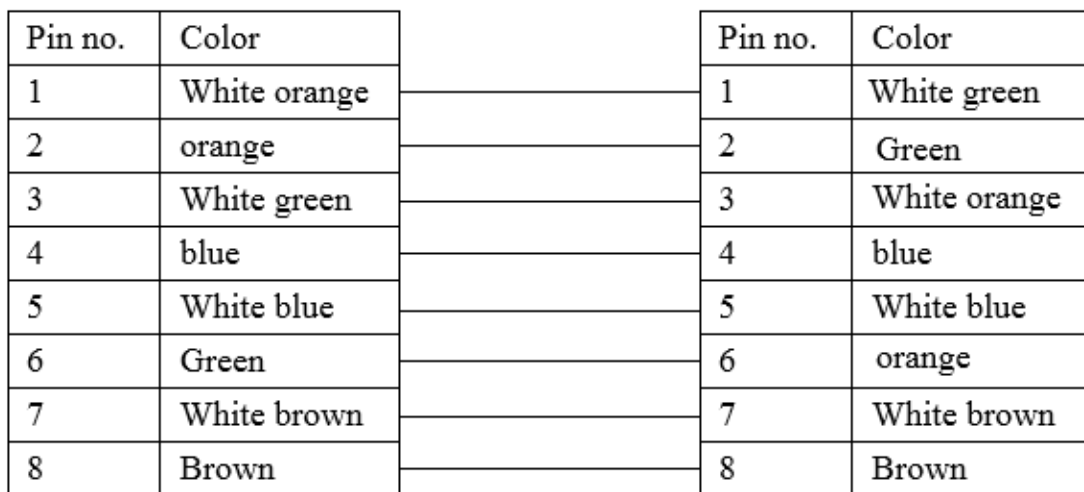

Fig 2

2.33.4 Device address

PLC address	Range	Object type	Notes
P	0.0~65535.F	Bit	Input/output
	0~65535	Word/DWord	Data register
M	0.0~65535.F	Bit	Internal auxiliary relay
	0~65535	Word/DWord	Data register
L	0.0~65535.F	Bit	Communication output
	0~65535	Word/DWord	Communication register
F	0.0~65535.F	Bit	Internal special relay
	0~65535	Word/DWord	Internal special data register
T	0~65535	Word/DWord	Timer present value
	0~65535	Bit	Timer
C	0~65535	Word/DWord	Counter present value
	0~65535	Bit	Counter
D	0~65535	Word/DWord	Data register
	0.0~65535.F	Bit	Bit of Data register
S	0~65535	Bit	Step relay
K	0~65535	Word/DWord	Retentive data register
	0.0~65535.F	Bit	Retentive relay
Z	0~65535	Word/DWord	Index data register
	0.0~65535.F	Bit	Index relay
N	0~65535	Word/DWord	Communication register
	0.0~65535.F	Bit	Communication relay
R	0~65535	Word/DWord	Data register
	0.0~65535.F	Bit	Relay
ZR	0~65535	Word/DWord	Data register
	0.0~65535.F	Bit	Relay
TS	0~65535	Word/DWord	Timer set value
CS	0~65535	Word/DWord	Counter set value

2.34 Mitsubishi FX series PLC

2.34.1 Device type

Series	CPU	Connected module	Port	Cable	PLC type in touchwin software
FX	FX0 FX1 FX1S/3S FX0N/1N/2N FX3SA-14MR-CM	CPU direct connection	RS422	Fig1	Mitsubishi FX series PLC
	FX2	CPU direct connection	RS422	Fig2	

2.34.2 Parameters

HMI settings:

Parameter	Recommend settings	Choices of settings	Item
PLC type	FX series		
Dat bit	7	7 or 8	
Stop bit	1	1 or 2	
Parity	Even parity	Even/odd/no parity	
Baud rate	9600	4800/9600/19200/38400/56000/57600/115200 /187500	
Station No.	0	0~255	

The default parameters of Mitsubishi FX series PLC: 9600, 7, 1, even, station No.0.

PLC settings:

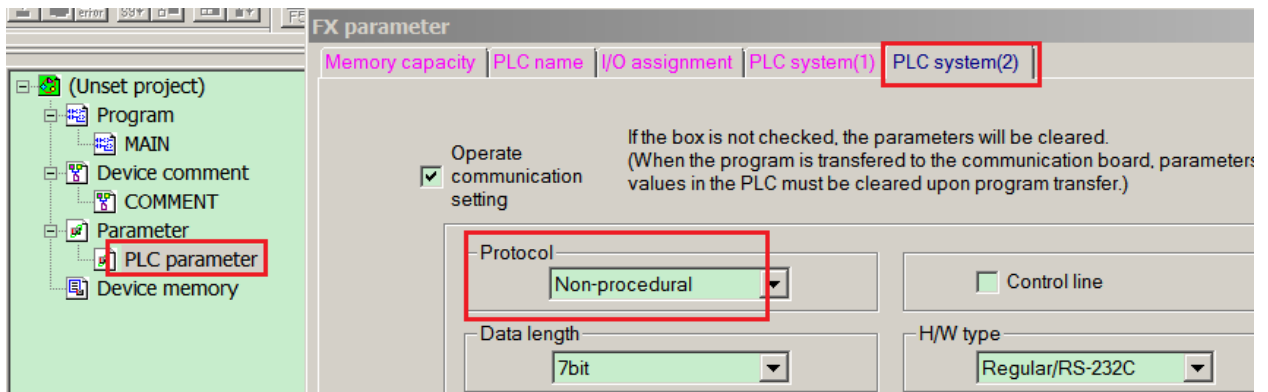

Note: Mitsubishi software parity is odd by default. However, when communicating with the Xinje HMI, the parity should choose even parity. Otherwise, the communication will not be available. After the communication parameters are written into the PLC, power off and then power on to take effect.

2.34.3 Cable making

(a) FX0/FX1/FX1S/FX0N/FX1N/FX2N series PLC, RS422 port:

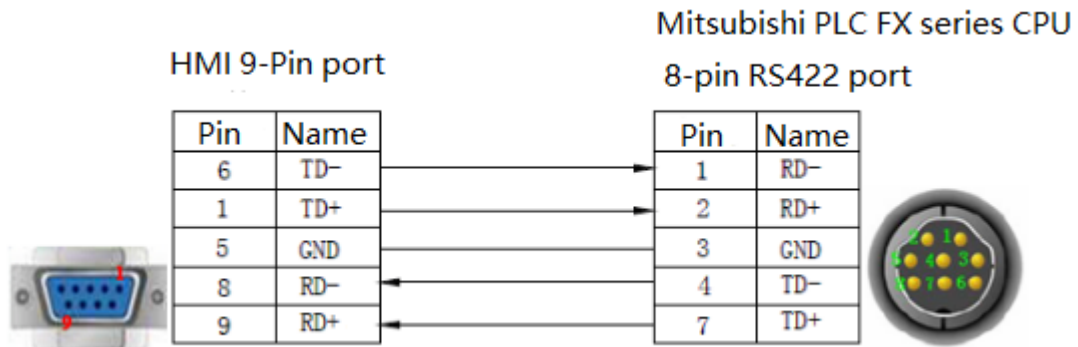

Fig1

(b) FX2 series PLC:

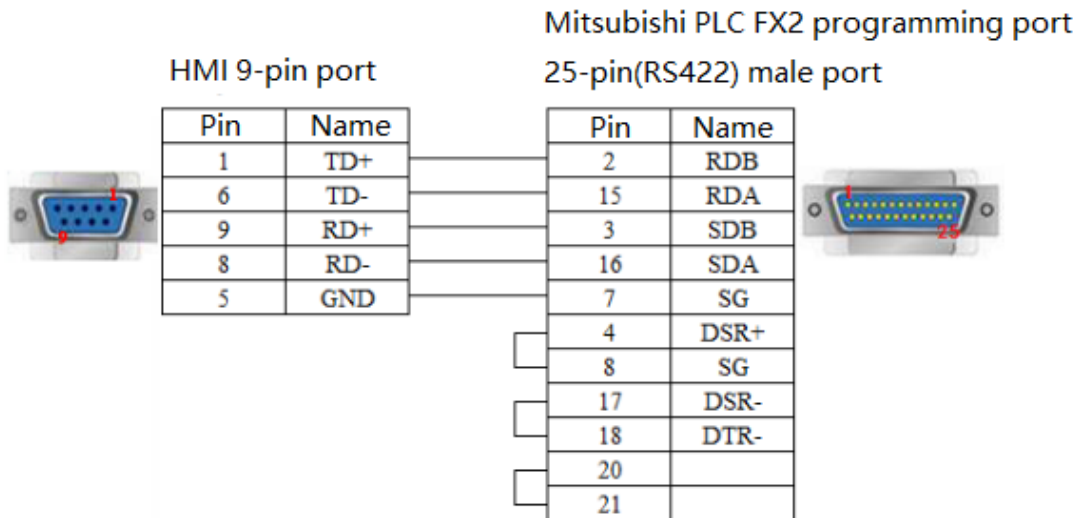

Fig2

2.34.4 Device address

PLC address	Range	Data type	Explanation
X	0~177	Bit	External input coil
Y	0~177	Bit	External output coil
M	0~8255	Bit	Internal coil
S	0~999	Bit	Stepper coil
T	0~255	Bit	Timer
C	0~255	Bit	Counter
C16	0~199	Word/DWord	16-bit counter
C32	200~255	DWord	32-bit counter
D	0~8255	Word/DWord	Data register
T	0~255	Word/DWord	Current value

X	0~177	Word/DWord	Data register
Y	0~177	Word/DWord	Data register
M	0~8255	Word/DWord	Data register
S	0~999	Word/DWord	Data register

2.35 Mitsubishi FX BD series PLC (RS232/485)

2.35.1 Device type

Series	CPU	Connected module	Port	Cable	PLC model in Touchwin software
FX	FX0N/1N/2N	232-BD	RS232	Fig1	Mitsubishi FX BD(232/485)
	FX1S FX3U/3G	485-BD	RS485	Fig2	

Note:

1. Do not hot plug the device!
2. The driver of 485-BD supports multi-station.

2.35.2 Parameters

HMI settings:

Parameters	Recommend settings	Choices of settings	Notes
PLC type	Mitsubishi FX BD(232/485)		
Data bit	7		
Stop bit	1		
Parity	Even parity		
Baud rate	9600	9600/19200/38400/56000/57600/ 115200/187500	
Station no.	0	0~255	

The default parameters of Mitsubishi FX BD (232/485): 9600, 7, 1, even parity, station no.0

PLC settings:

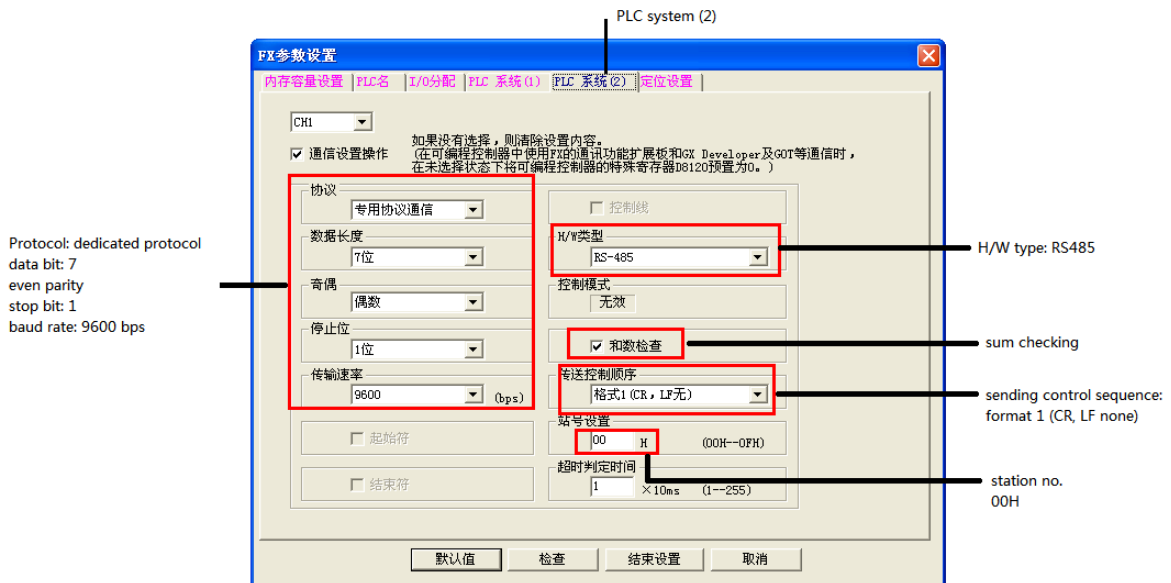

Note:

1. Please choose RS232 as H/W type when using 232-BD.
2. Please re-power on the PLC after changing the parameters.

2.35.3 Cable making

(a) FX series PLC RS232-BD:

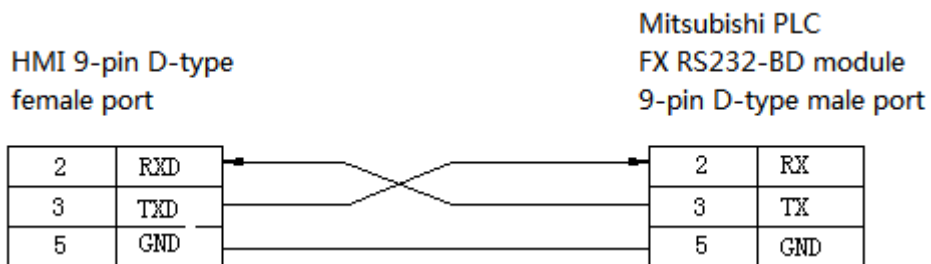

Fig1

(b) FX series PLC RS485-BD:

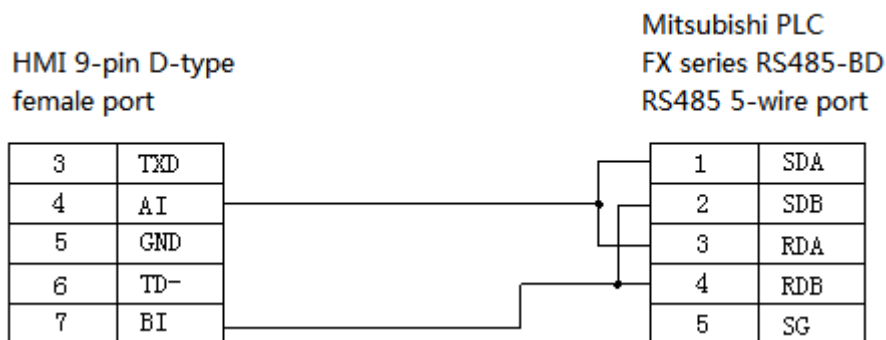

Fig2

2.35.4 Device address

PLC address	Range	Data type	Explanation
X	0~177	Bit	External input terminal
Y	0~177	Bit	External output terminal
M	0~8255	Bit	Internal auxiliary coil
S	0~999	Bi	Stepper coil
T	0~255	Bit	Timer
C	0~255	Bit	Counter
C16	0~199	Word/DWord	16-bit counter
C32	200~255	DWord	32-bit counter
D	0~8255	Word/DWord	Data register
T	0~255	Word/DWord	Current value
X	0~177	Word/DWord	Used as data register
Y	0~177	Word/DWord	Used as data register
M	0~8255	Word/DWord	Used as data register
S	0~999	Word/DWord	Used as data register

2.36 Mitsubishi FX3U/G/GA series PLC

2.36.1 Device type

Series	CPU	Connected module	Port	Cable	PLC model in Touchwin software
FX	FX3U FX3G FX3GA	CPU	RS422	Fig 1	Mitsubishi FX3U/G

2.36.2 Parameters

HMI settings:

Parameter	Recommended settings	Choices of settings	Notes
PLC type	Mitsubishi FX3U/G series		
Data bit	7		
Stop bit	1		
Parity	Even parity		
Baud rate	9600	4800/9600/19200/38400/56000/57600/115200/187500	
Station no.	0		

The default parameters of Mitsubishi FX3U/G series PLC: 9600, 7, 1, even parity, station no.0

PLC settings:

2.36.3 Cable making

FX3U/3G series PLC RS422:

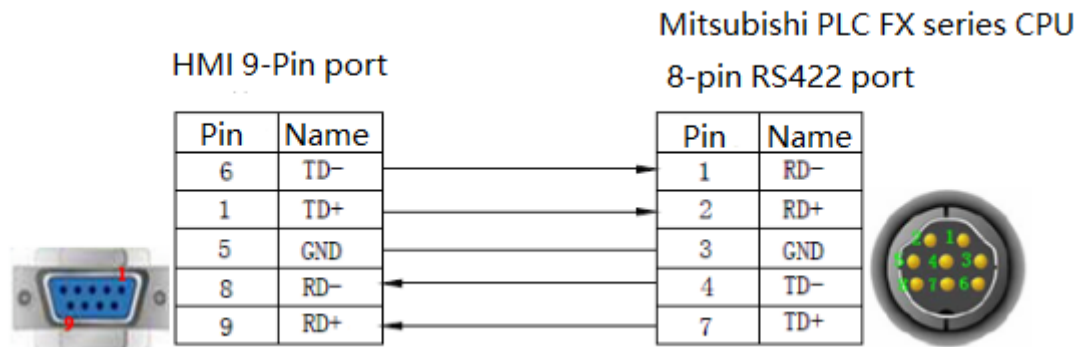

Fig 1

2.36.4 Device address

PLC address	Range	Type	Explanation
X	0~177	Bit	External input terminal
Y	0~177	Bit	External output terminal
M	0~8255	Bit	Internal auxiliary coil
S	0~999	Bit	Stepper coil
T	0~255	Bit	Timer
C	0~255	Bit	Counter
C16	0~199	Word/DWord	16-bit counter
C32	200~255	DWord	32-bit counter
D	0~8255	Word/DWord	Data register
SD	8000~9999	Word/DWord	Special data register
TD	0~511	Word/DWord	Timer
R	0~32767	Word/DWord	Extended data register

2.37 Mitsubishi FX5U series PLC

2.37.1 Device type

Series	CPU	Connected module	Port	Cable	PLC model in Touchwin software
FX5U series		CPU unit connect directly	RS485	Fig 1	Mitsubishi FX5U series

2.37.2 Parameter setting

HMI setting

Parameter	Recommended setting	Optional setting	Notes
PLC type	Mitsubishi FX5U series	Mitsubishi FX5U series/ Mitsubishi Q series	When choose Q series, the I/O is decimal format
Port type	RS485		
Data bit	8		
Stop bit	1		
Parity	Odd		
Baud rate	19200		
Station no.	0		Please use the recommended settings

Mitsubishi FX5U series communication parameter setting

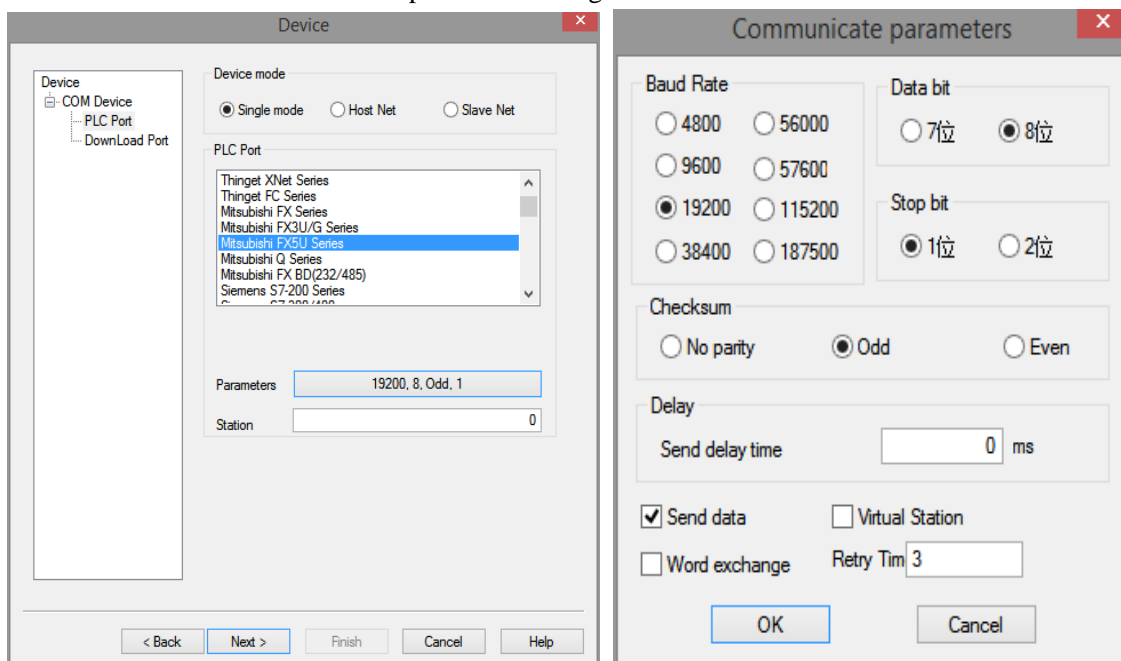

Note: the HMI station no. is 0, it cannot change

PLC setting

(1)MC protocol communication

Please set the protocol format to MC protocol in RS485 serial port. The transfer mode is set to mode 5.

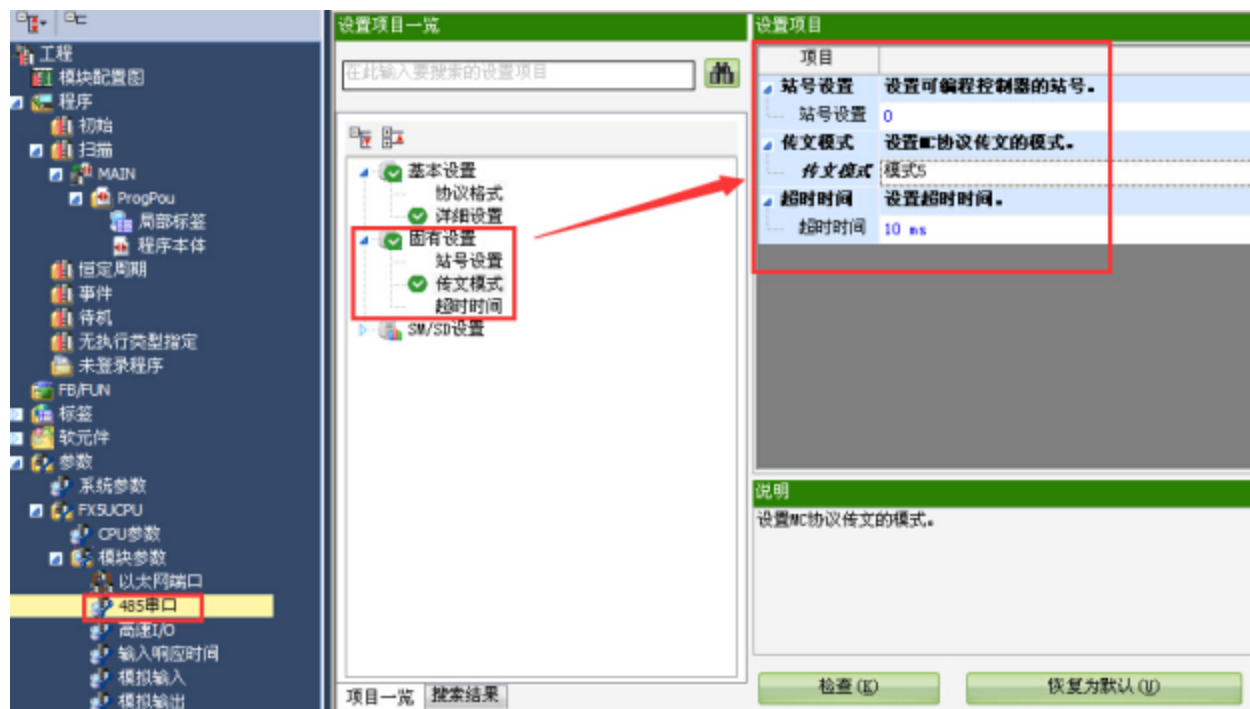
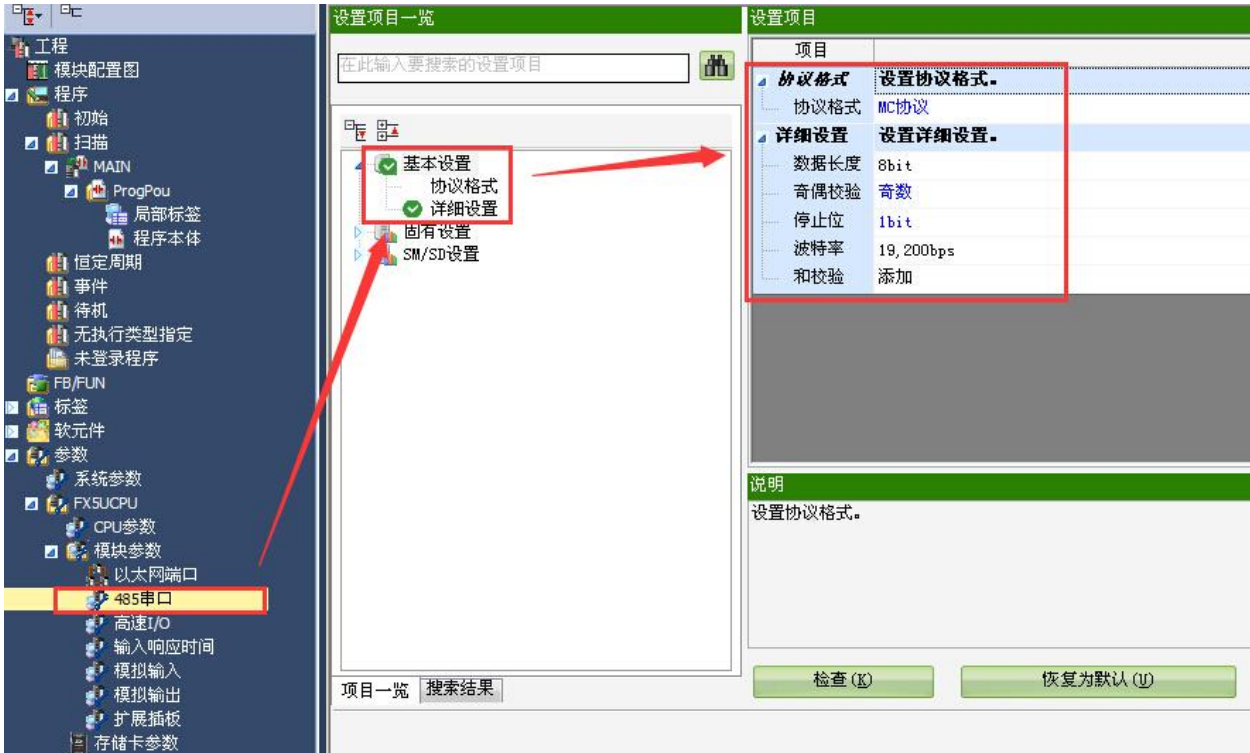

(2) Modbus RTU communication

The HMI please choose “Modbus RTU” protocol.

Please set the protocol format to Modbus RTU in RS485 serial port, and set the Modbus station no. to non-zero number, the HMI parameters must be same to PLC settings.

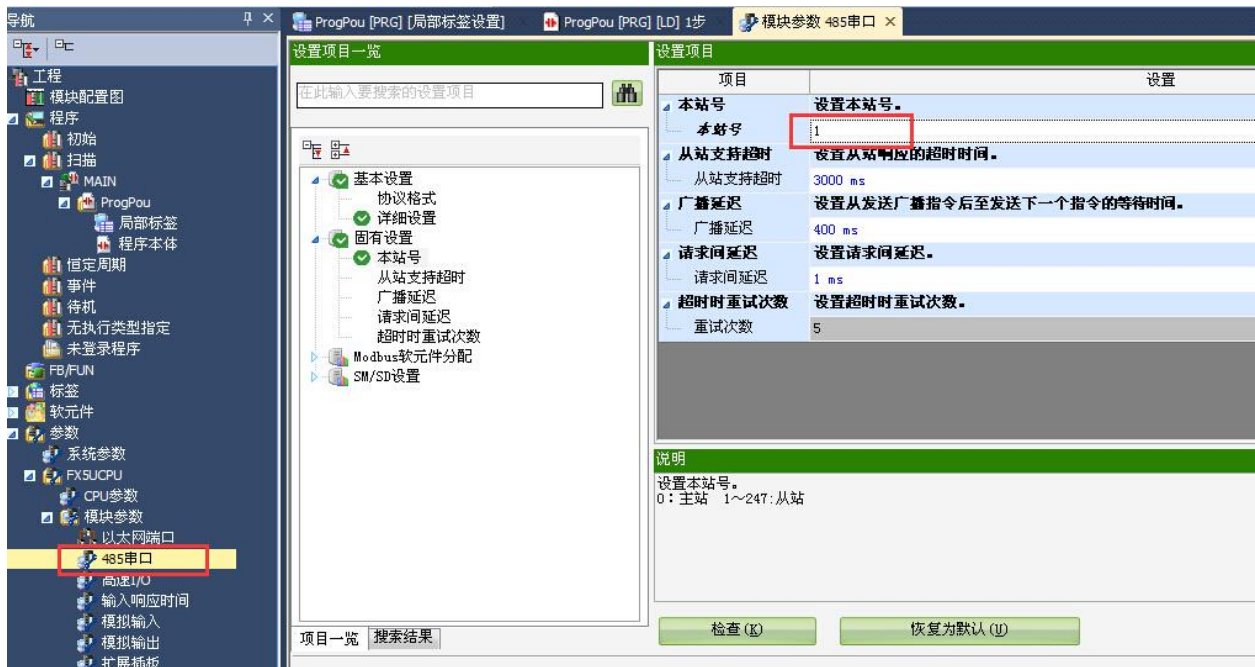
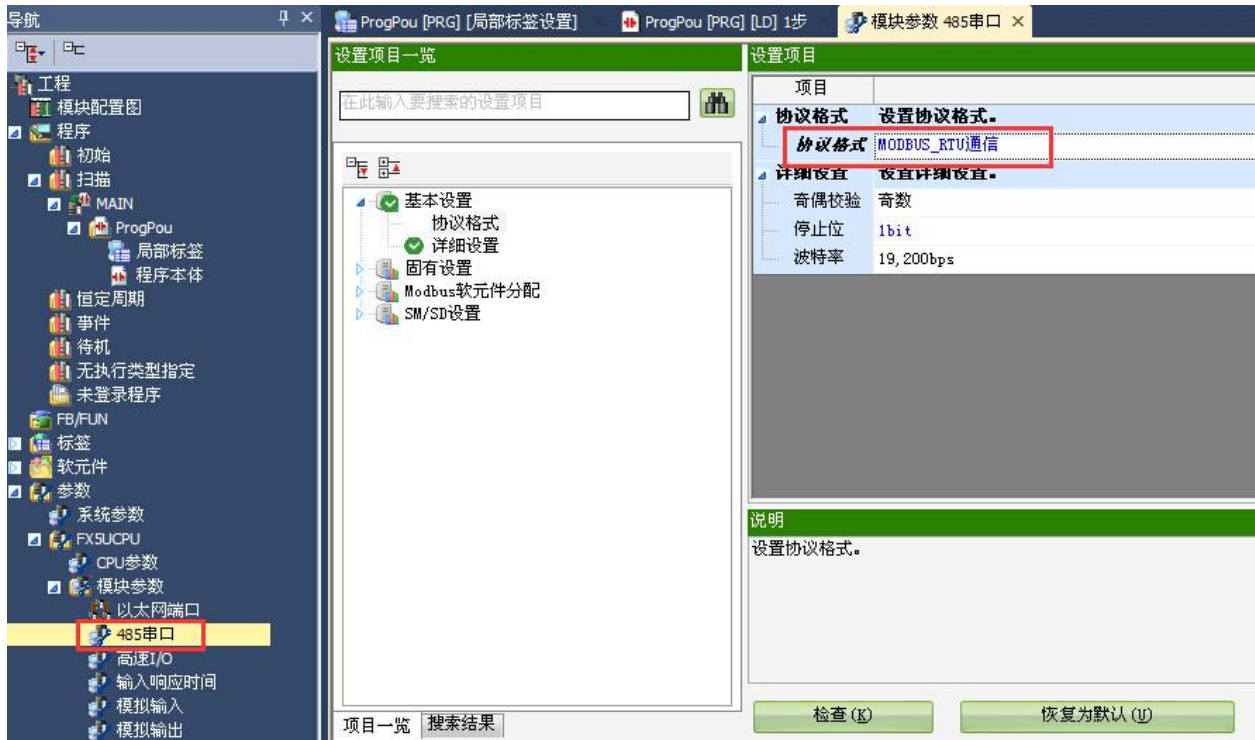

Notes: PLC has fixed Modbus address in Modbus communication, it will read and write as the address.



2.37.3 Cable making

Please use the RS485 port on FX5U CPU unit.

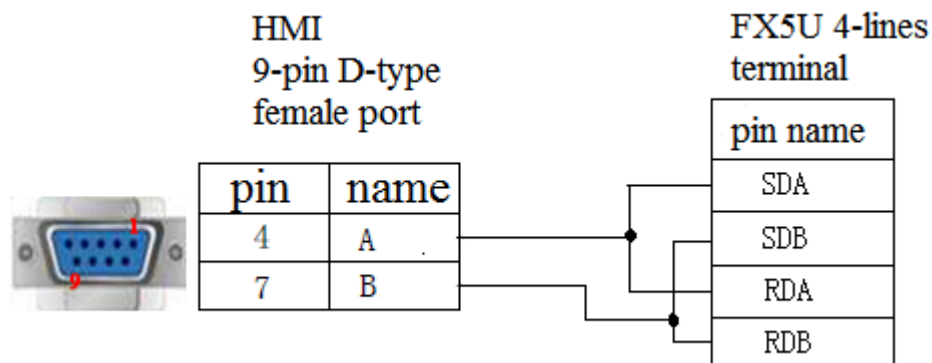

Fig1

2.37.4 Device address

PLC address type	Range	Object type	Explanation
X	0~8191	Bit	Input
Y	0~8191	Bit	Output
M	0~8191	Bit	Internal auxiliary relay
B	0~8191	Bit	Linkage relay
SB	0~2047	Bit	Internal special linkage relay
DX	0~8191	Bit	Direct input
DY	0~8191	Bit	Direct output
S	0~8191	Bit	Step relay
SM	0~2047	Bit	Internal special step relay
L	0~8191	Bit	Locking relay
F	0~2047	Bit	Alarm
V	0~2047	Bit	Variable address relay
TS	0~2047	Bit	Timer contactor
TC	0~2047	Bit	Timer coil
SS	0~2047	Bit	Accumulated timer contactor
SC	0~2047	Bit	Accumulated timer coil
CS	0~1023	Bit	Counter contactor
CC	0~1023	Bit	Counter coil
D	0~12287	Word/DWord	Data register
W	0~8191	Word/DWord	Linkage register
SW	0~2047	Word/DWord	Internal special linkage register
ZR	0~1042431	Word/DWord	File register
SD	0~2047	Word/DWord	Internal special register

TN	0~2047	Word/DWord	Timer
SN	0~2047	Word/DWord	Accumulated timer
CN	0~1023	Word/DWord	Counter
Z	0~15	Word/DWord	Variable register
R	0~32767	Word/DWord	File register

2.38 Mitsubishi Q series PLC

2.38.1 Device type

MELSEC-Q series include the CPU unit of Q00, Q01, Q00U and so on. They can connect to the HMI via programmable port or communication module (QJ71C24N).

Series	CPU	Connected module	Port	Cable	PLC model in Touchwin software
Q	Q00 Q01 Q00U Q00UJ	CPU direct connection	RS232	Fig 1	Mitsubishi Q series
	Q01U	CPU direct connection	RS232	Fig 1	
	Q00J Q02 Q03 Q02H Q06H Q12H Q25H Q12PH Q25PH	Serial communication module QJ71C24 QJ71C24N	RS232	Fig 2	
	RS422		Fig 3		
L	L02CPU L02SCPU-CM	CPU direct connection	RS422	Fig 3	

2.38.2 Parameters

HMI settings:

Parameter	Recommend setting	Choices of settings	Item
PLC type	Q series		
Data bit	8	7 or 8	
Stop bit	1	1 or 2	
Parity	Odd parity	Even/odd/no parity	
Baud rate	19200	4800/9600/19200/38400/56000/57600/115200/187500	
Station No.	0	0~255	

The default parameter of Q series PLC: 19200, 8, 1, odd parity, station No.0.

PLC settings:

1.Q01/Q00/Q00U/Q00UJ PLC:

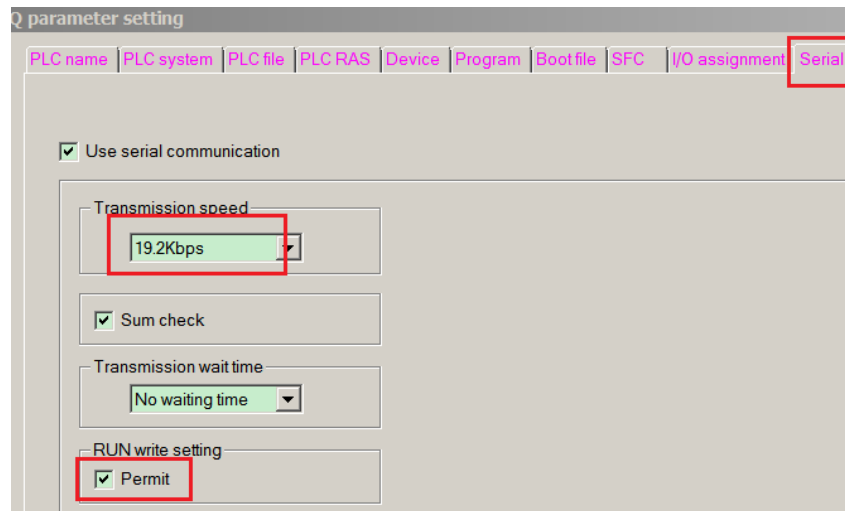

2.QJ71C24N serial port module

QJ71C24N can connect to CPU and communicate with other devices. Such as Q02CPU, the settings are as the following:

PLC software version v8.26

(a) Double click PLC parameter, choose I/O assignment:

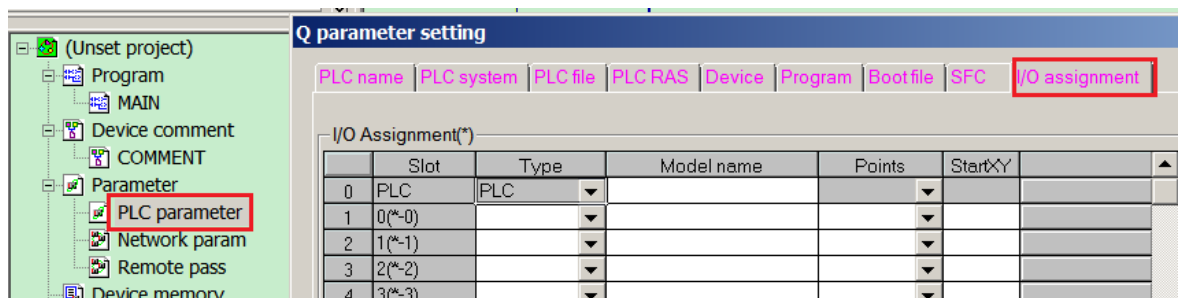

(b) Change the type of item1 to intelli.

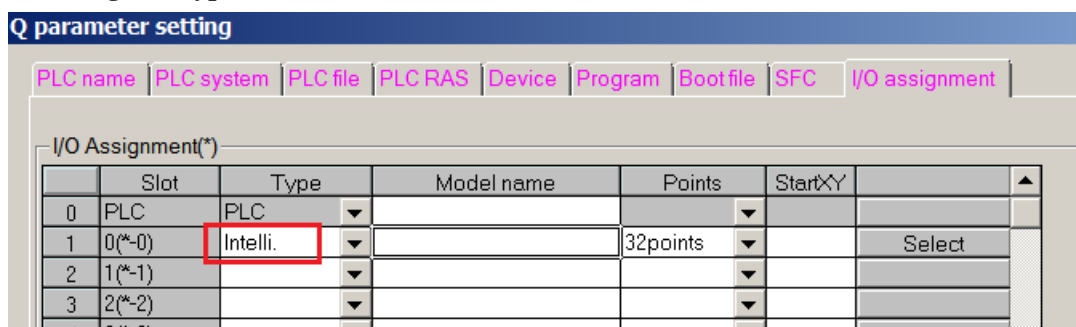

(c) Click "switch setting":

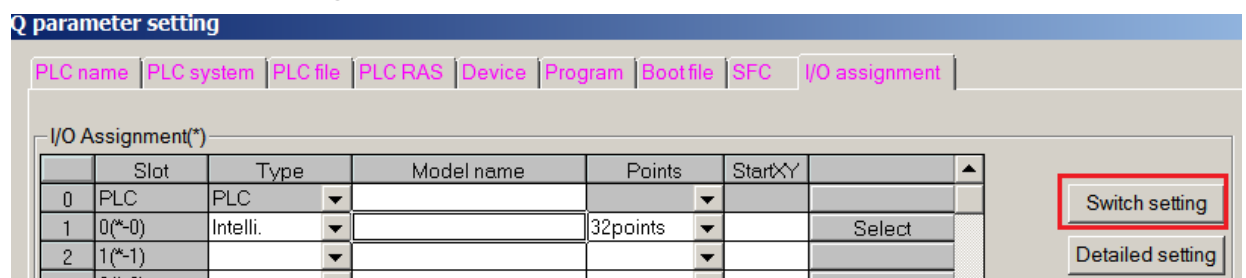

(d) Set the parameter as the following window:

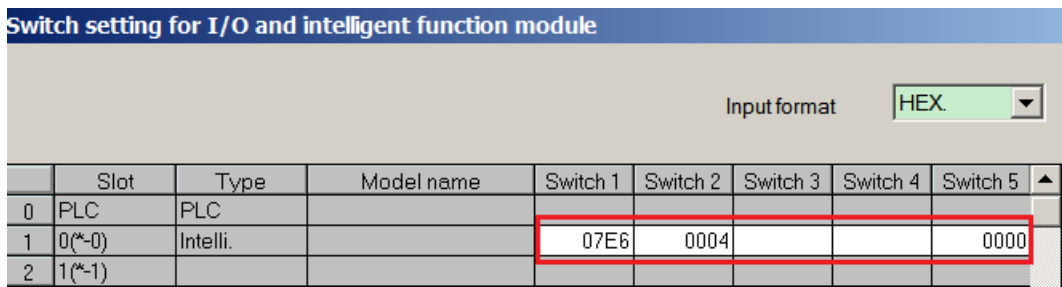

(e) Click End button to finish the settings, then repower on the PLC.

Note: the set value combination of switch 1 to switch 5 is 16 bit binary data, and the transmission specification and communication protocol of each interface can be set.

Switch 1: communication speed and transmission setting of CH1. 07E6 represents that the communication parameters are 19200 baud rate, 8 data bits, 1 stop bit, odd check, writing and setting are allowed during operation, and there is sum check.

Switch 2: communication protocol setting of ch1, 0004 represents MC protocol format 4.

Switch 3: the communication speed and transmission setting of CH2 should be set when RS232 of QJ71C24 (N) module is used.

Switch 4: communication protocol setting of CH2. This item shall be set when RS232 of QJ71C24 (N) module is used.

Switch 5: CH1 and CH2 are shared for station number setting of MC protocol communication, and 0000 represents station number 0.

PLC software version v8.8:

For QJ71C24 module RS232, please set the parameter of CH1:

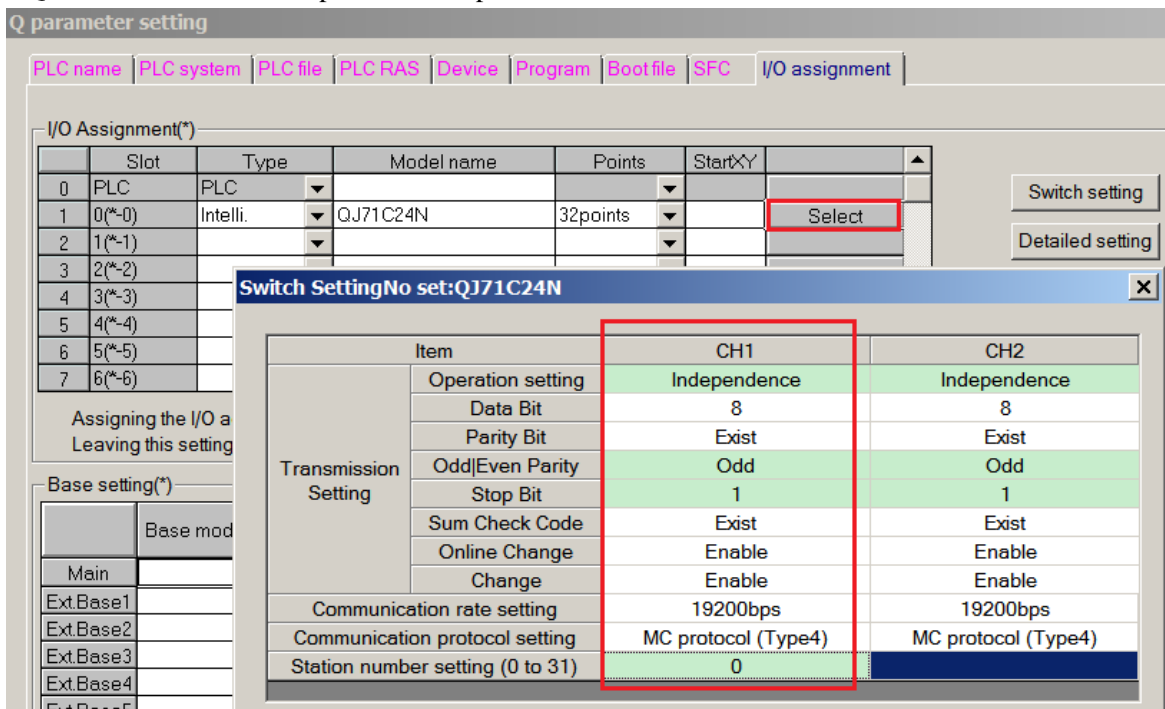

For QJ71C24 module RS422, please set the parameter of CH2:

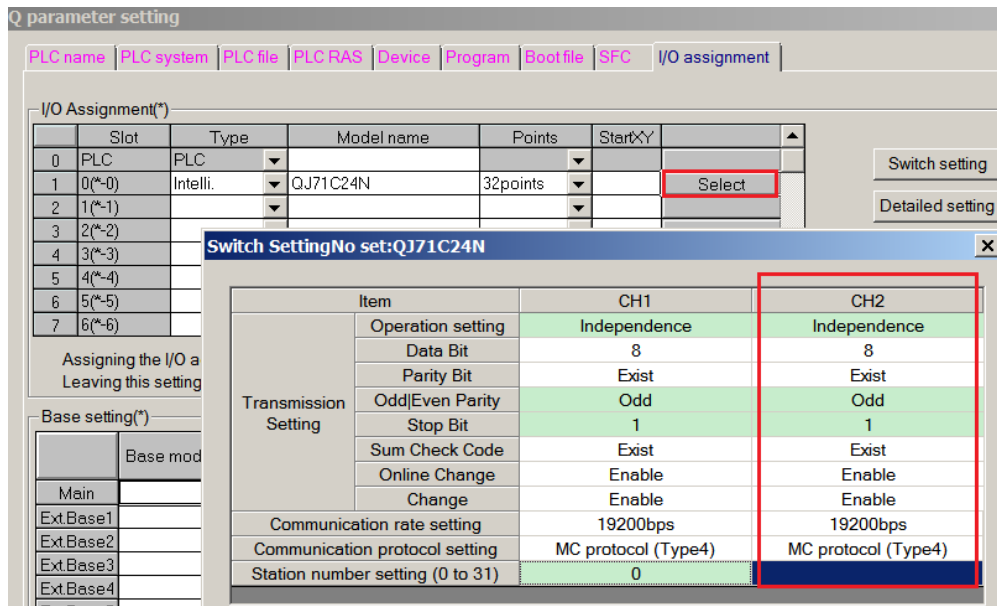

2.38.3 Cable making

(a) Q series PLC CPU unit, RS232 port:

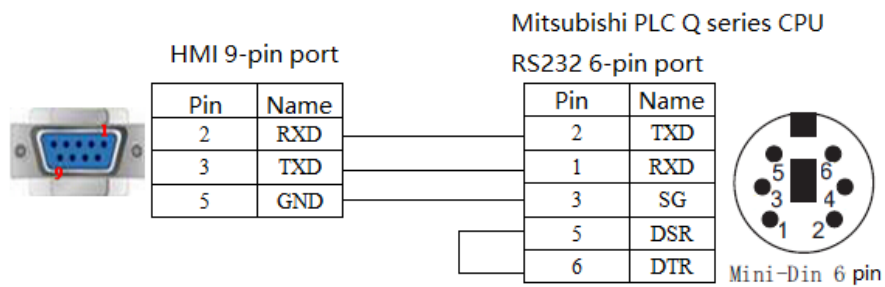

Fig1

(b) Q series PLC uses QJ71C24(N) module RS232:

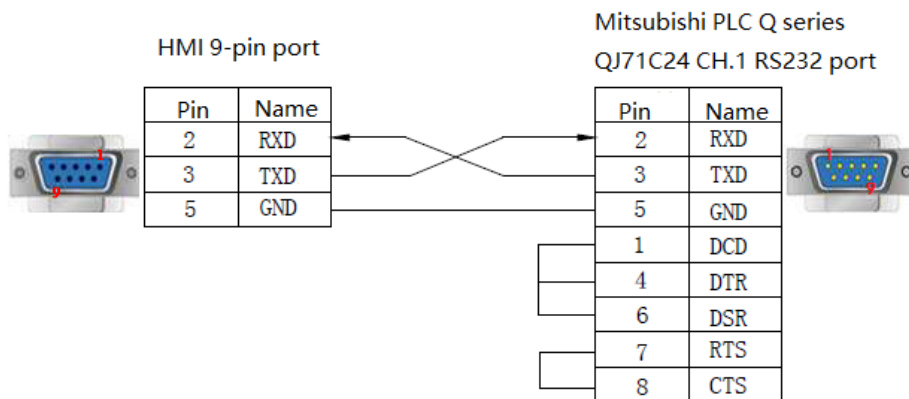

Fig2

(c) Q series PLC uses QJ71C24(N) module RS422:

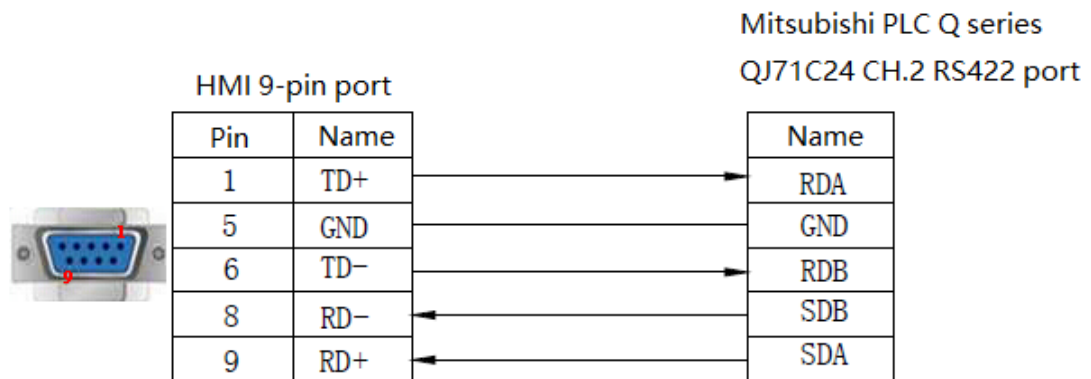

Fig3

2.38.4 Device address

PLC address	Range	Data type	Explanation
X	0~8191	Bit	External input coil
Y	0~8191	Bit	External output coil
M	0~8191	Bit	Internal coil
B	0~8191	Bit	Link Relay
SB	0~2047	Bit	Internal special link Relay
DX	0~8191	Bit	Direct input
DY	0~8191	Bit	Direct output
S	0~8191	Bit	Step relay
SM	0~2047	Bit	Internal special step relay
L	0~8191	Bit	Latching relay
F	0~2047	Bit	Alarm
V	0~2047	Bit	Variable address relay
TS	0~2047	Bit	Timer contactor
TC	0~2047	Bit	Timer coil
SS	0~2047	Bit	Accumulated timer contactor
SC	0~2047	Bit	Accumulated timer coil
CS	0~1023	Bit	Counter contactor
CC	0~1023	Bit	Counter coil
D	0~12287	Word/DWord	Data register
W	0~8191	Word/DWord	Linkage register
SW	0~2047	Word/DWord	Internal special linkage register

PLC address	Range	Data type	Explanation
ZR	0~1042431	Word/DWord	File register
SD	0~2047	Word/DWord	Internal special register
TN	0~2047	Word/DWord	Timer
SN	0~2047	Word/DWord	Accumulated timer
CN	0~1023	Word/DWord	Counter
Z	0~15	Word/DWord	Variable register
R	0~32767	Word/DWord	File register

2.39 Mitsubishi Q02H series

2.39.1 Device type

Series	CPU	Connected module	Port	Cable	PLC model in Touchwin software
Q	Q02 Q02H	CPU direct connection	RS232	Fig 1	Mitsubishi Q02H
L	L02 L06CPU-CM	LJ71C24-CM	RS232	Fig 2	
			RS422	Fig 3	

2.39.2 Parameters

HMI settings

Parameter	Recommended setting	Optional setting	Notes
PLC type	Q02H series		
Data bit	8		
Stop bit	1		
Parity	Odd parity		
Baud rate	115200	9600/19200/38400/57600/115200	
Station no.	0	0~255	

PLC settings:

- 1) Mitsubishi Q02 series PLC default communication parameters: 115200, 8, 1, odd, station No.: 0, no need to modify.
- 2) L series LJ71C24 module communication, serial port settings are as follows (PLC software version is GX works 2 version 1.555D):

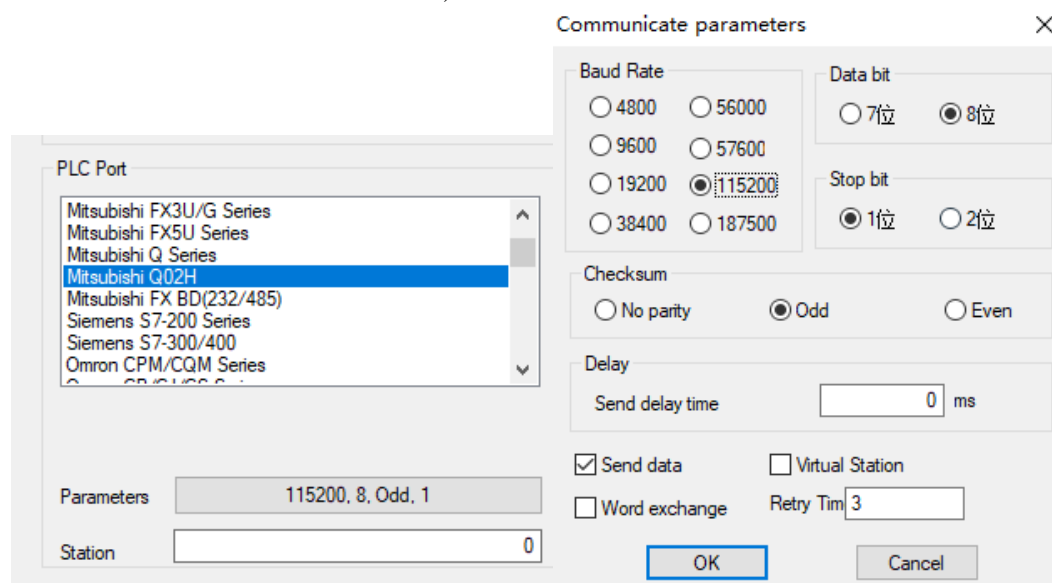

Add module information to PLC software:

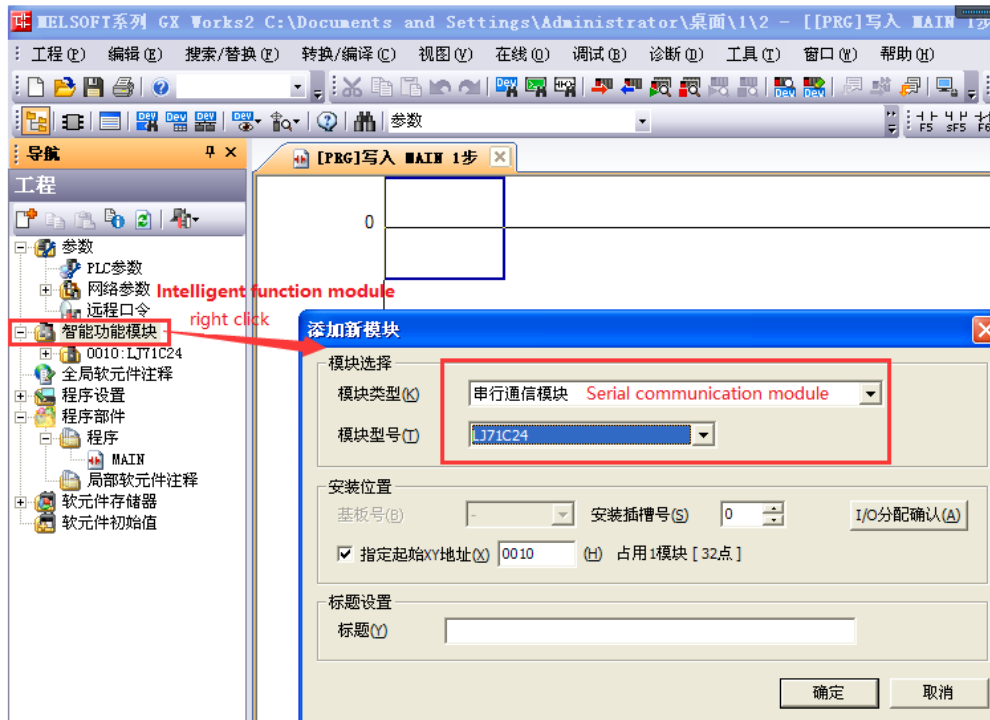

There are two methods to configure module parameters: in module parameters and in PLC parameters. The two parts are related to each other. For example, if the parameter is modified in the module parameter, the corresponding parameter in the PLC parameter will be modified automatically.

Method 1: Configure in module parameters:

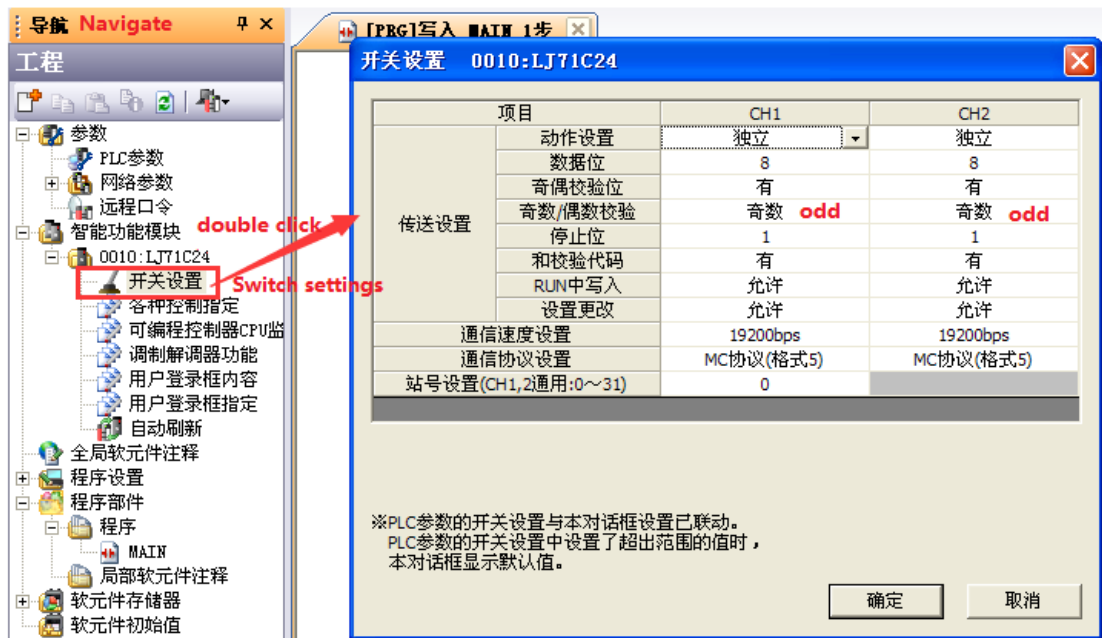

Note: CH1 is the 232 channel of LJ71C24-CM module, and CH2 is the 422 channel of LJ71C24-CM module.

Method 2: Configure in PLC parameters.

(a) Click "I/O assignment" in the upper right corner of the "I/O allocation" panel to open the following dialog box:

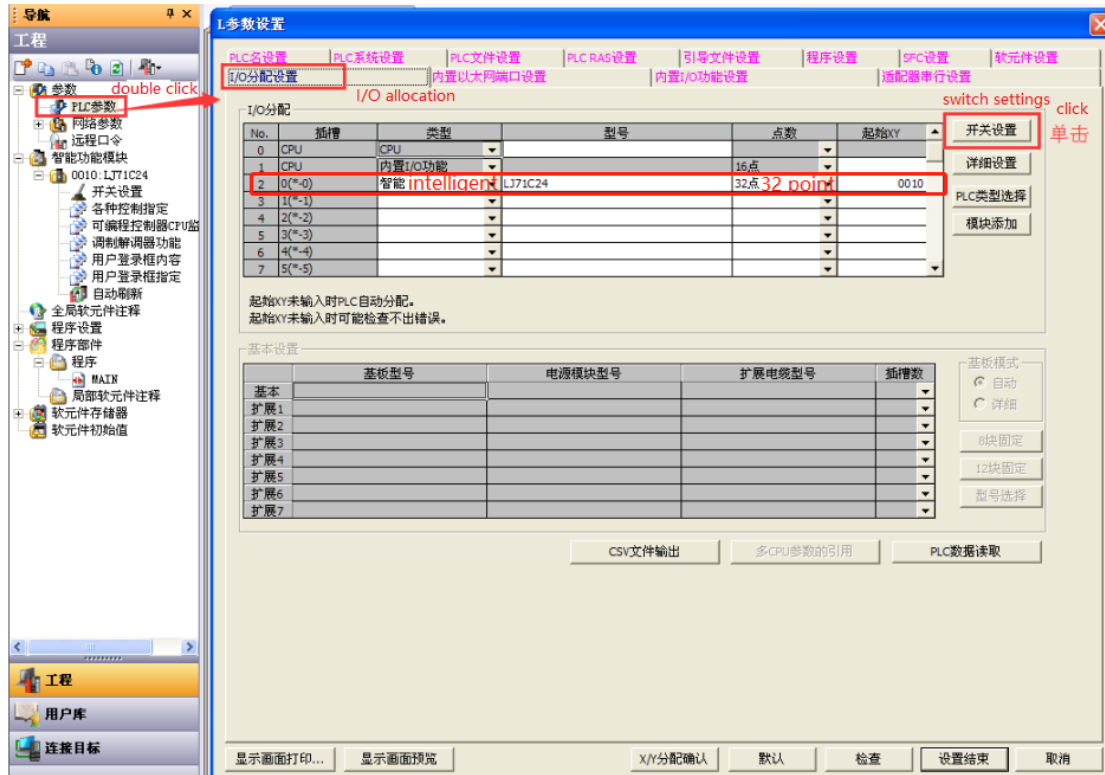

(b) Click "I/O allocation"-"switch settings", open the following dialog box.



Set the parameters in the "smart" line:

The set values of switch 1 to switch 5 are combined into 16 bit binary data, and the transmission

specifications and communication protocols of each interface can be set:

Switch 1: set communication speed and transmission of CH1. 07E6 represents 19200 baud rate, 8 data bit, 1 stop bit, odd check, writing and setting are allowed during operation, and sum check.

Switch 2: set communication protocol of CH1, 0005 represents MC protocol format 5.

Switch 3: the communication speed and transmission setting of CH2 should be set when RS422 of LJ71C24 module is used.

Switch 4: communication protocol setting of CH2. This item should be set when RS422 of LJ71C24 module is used.

Switch 5: CH1 and CH2 are shared for station number setting of MC protocol communication, and 0000 represents station number 0.

Please refer to relevant descriptions of Mitsubishi L series serial communication module for details.

Note: CH1 is the 232 channel of LJ71C24-CM module, and CH2 is the 422 channel of LJ71C24-CM module.

(c) Click the "end of setting" button to download the parameters to the PLC, and then power on the PLC again.

2.39.3 Cable making

(a) Q series PLC CPU unit, RS232 port:

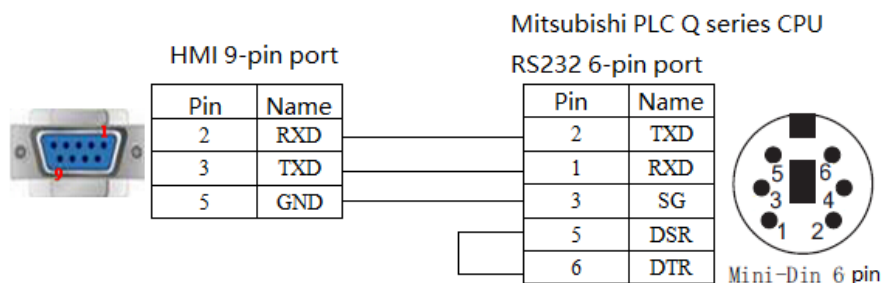

Fig 1

(b) L series PLC uses LJ71C24 module RS232:

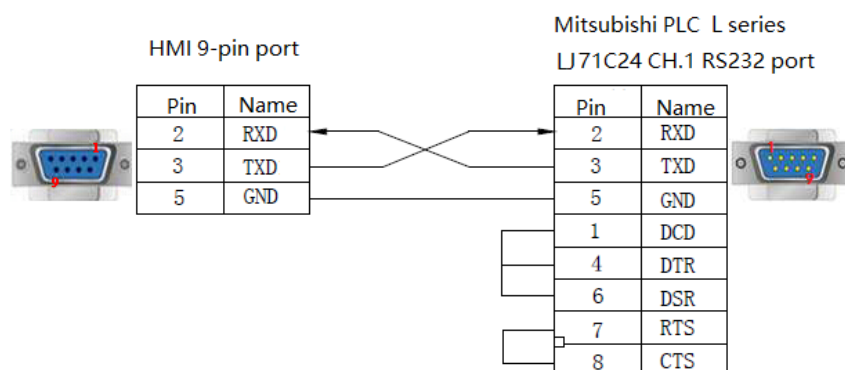

Fig 2

(c) L series PLC uses LJ71C24 module RS422:

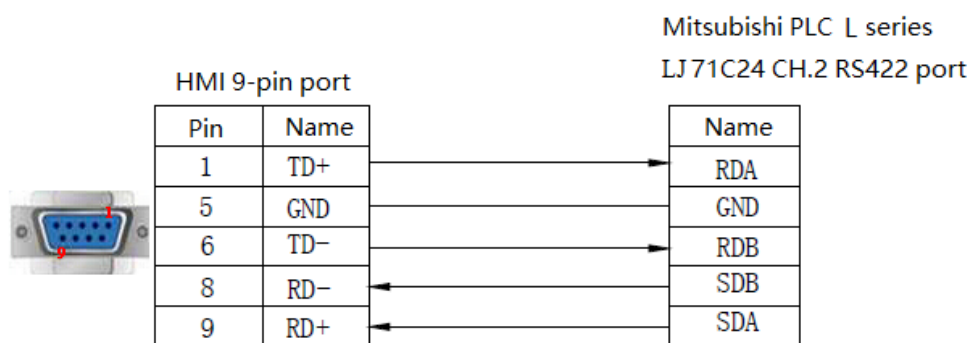

Fig 3

2.39.4 Device address

PLC address	Range	Data type	Explanation
X	0~8191	Bit	External input coil
Y	0~8191	Bit	External output coil
M	0~8191	Bit	Internal coil
B	0~8191	Bit	Link Relay
SB	0~2047	Bit	Internal special link Relay
DX	0~8191	Bit	Direct input
DY	0~8191	Bit	Direct output
S	0~8191	Bit	Step relay
SM	0~2047	Bit	Internal special step relay
L	0~8191	Bit	Latching relay
F	0~2047	Bit	Alarm
V	0~2047	Bit	Variable address relay
TS	0~2047	Bit	Timer contactor
TC	0~2047	Bit	Timer coil
SS	0~2047	Bit	Accumulated timer contactor
SC	0~2047	Bit	Accumulated timer coil
CS	0~1023	Bit	Counter contactor
CC	0~1023	Bit	Counter coil
D	0~12287	Word/DWord	Data register
W	0~8191	Word/DWord	Linkage register
SW	0~2047	Word/DWord	Internal special linkage register
ZR	0~1042431	Word/DWord	File register
SD	0~2047	Word/DWord	Internal special register
TN	0~2047	Word/DWord	Timer
SN	0~2047	Word/DWord	Accumulated timer
CN	0~1023	Word/DWord	Counter
Z	0~15	Word/DWord	Variable register
R	0~32767	Word/DWord	File register

2.40 Mitsubishi FR series inverter

2.40.1 Device type

Series	Connected module	Port	Cable	PLC model in Touchwin software
FR	RS485 port on CPU unit	RS485	Fig 1	Mitsubishi FR series inverter Modbus RTU (panel is Master)

2.40.2 Parameters

1. Select Mitsubishi FR series drive protocol:

HMI:

Parameters	Recommended setting	Choices of settings	Notes
PLC type	Mitsubishi FR series	-	-
Port type	RS485	RS485	
Data bit	8	-	
Stop bit	2	-	
Parity	Even parity	-	
Baud rate	19200	9600/115200/19200/187500	
Station no.	0	0~31	

Inverter parameters:

Function (FR)	Name	Default value	Range	Debug parameters
P117	Station no.	0	0~31, 0~247	0
P118	Baud rate	19.2kbps	4800bps, 9600bps, 38400bps	19200
P119	Stop bit, data bit	1	0: 1 stop bit, 8 data bit 1: 2 stop bit, 8 data bit 10: 1 stop bit, 7 data bit 11: 2 stop bit, 7 data bit	1: 2 stop bit, 8 data bit
P120	Parity	2	0: no parity 1: odd parity 2: even parity	2: even parity
P121	Retry times	9999		9999
P122	Test time	0	0: RS485 9999: no communication test	0
P123	Wait time	150ms		125
P124	R/LF	0	0: without CR, LF 1: with CR 2: with R, LF	0

P549	Protocol selection	0	0:Mitsubishi Inverter protocol 1: Modbus RTU protocol	Effective after restarting the frequency converter
P79	Mode selection	0	0~7	Set to 2, external communication mode, please cut off the power of inverter after setting the parameters
P340	Communication start mode	0	0, 1, 10	Set to 1, start in network running mode

2.Select Modbus RTU (Panel is Master):

HMI:

Parameter	Recommended settings	Choices of settings	Note
PLC type	Modbus Rtu (Panel is Master)	-	-
Port type	RS485	RS485	
Data bit	8	-	
Stop bit	2	-	
Parity	Even parity	-	
Baud rate	19200	9600/115200/19200/187500	
Station no.	1	0~31	

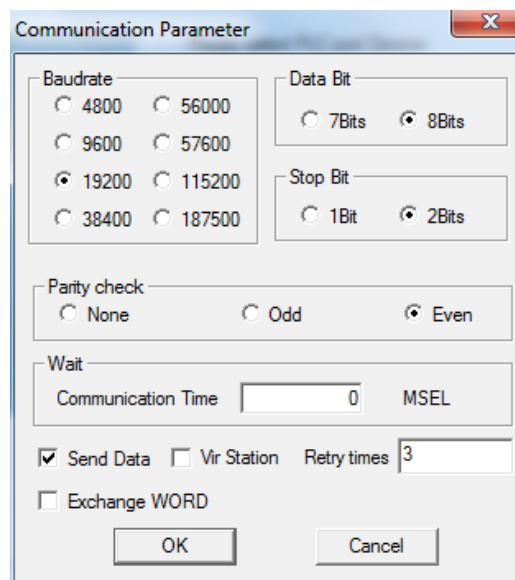

Inverter parameters:

Function (FR)	Name	Default value	Range	Debug parameters
P117	Station no.	1	0~31, 0~247	1 (Modbus station no. can not be 0)
P118	Baud rate	19.2kbps	4800bps,9600bps,38400	19200

			bps	
P119	Stop bit	1	0: 1 stop bit, 8 data bit 1: 2 stop bit, 8 data bit 10: 1 stop bit, 7 data bit 11: 2 stop bit, 7 data bit	1: 2 stop bit, 8 data bit
P120	Parity	Even	0: no parity 1: odd parity 2: even parity	2: even parity
P121	Retry times	9999		9999
P122	Communication test	0	0: RS485 9999: no communication test	0
P123	Waiting time	150ms		125
P124	CR/LF selection	0	0: without CR, LF 0: with CR 0: with R, LF	0
P549	Protocol selection	1	Modbus-RTU	Be valid after restarting the inverter
P79	Mode selection	0	0~7	Set to 2, external communication mode, please cut off the power of inverter after setting the parameters
P340	Communication start mode	0	0, 1, 10	Set to 1, start in network running mode

2.40.3 Cable making

RS485 cable:

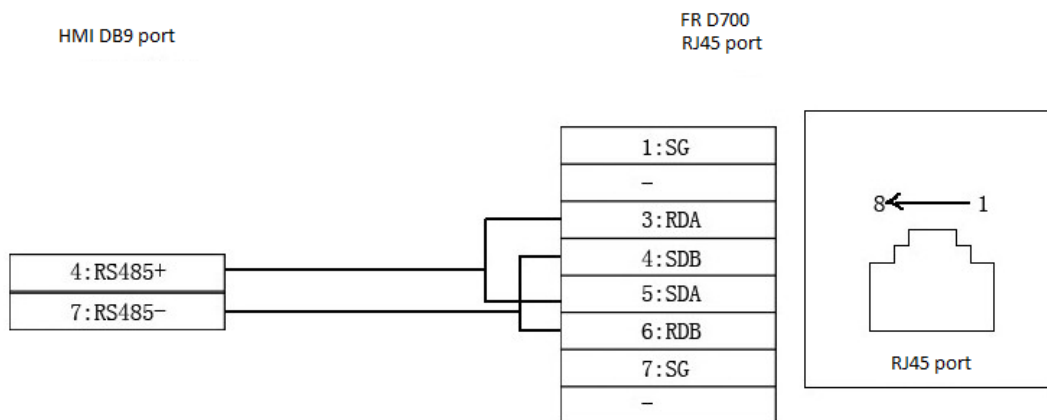

Fig 1

2.41 Mitsubishi Melsec 1E(Ethernet) series PLC

2.41.1 Device type

Series	CPU	Connected module	Port	Cable	PLC model in Touchwin software
FX	FX3U	FX3U-ENET-L	RJ45	Fig1or Fig2	Mitsubishi Melsec(1E)

2.41.2 Parameters

Take Mitsubishi FX3U series module FX3U-ENET-L as an example to explain the communication settings of Mitsubishi MELSEC (1E) protocol equipment.

PLC software settings

1. Open the FX3U-ENET-L configuration software, and select the module number to be configured in the software, as shown in the following figure:

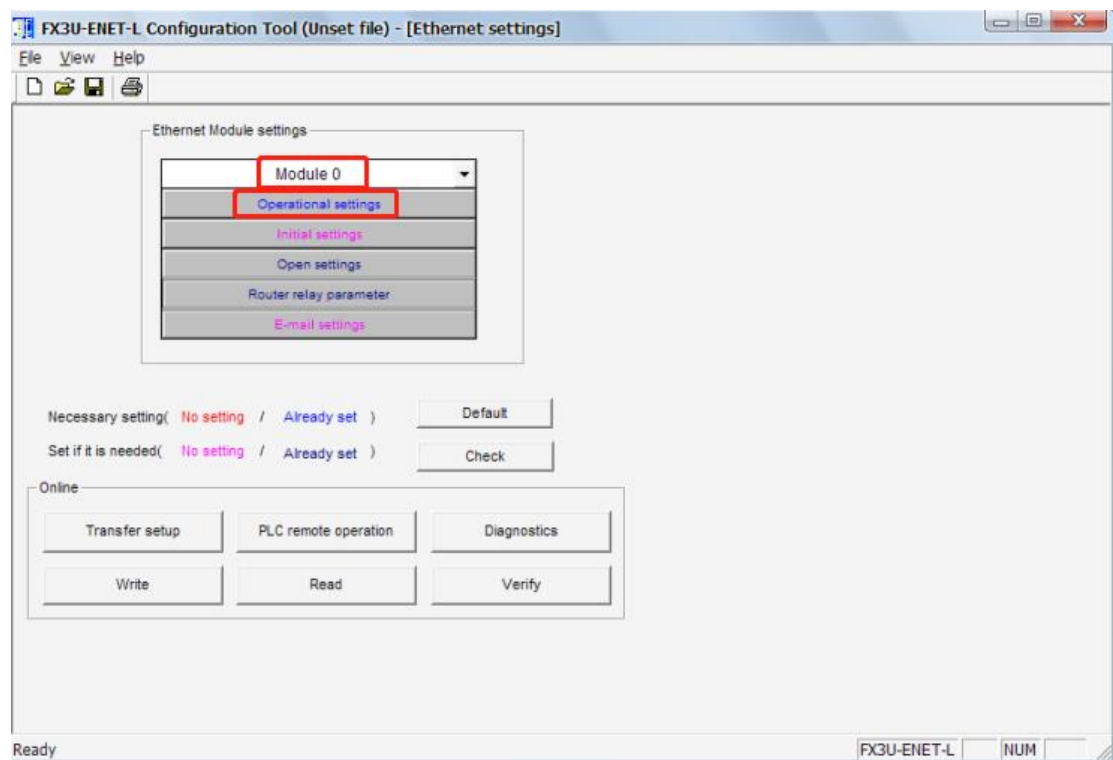

2. Select "operational settings" and double click the left mouse button to open the following window to add the IP address of the station. Other parameters are set as shown in the following figure:

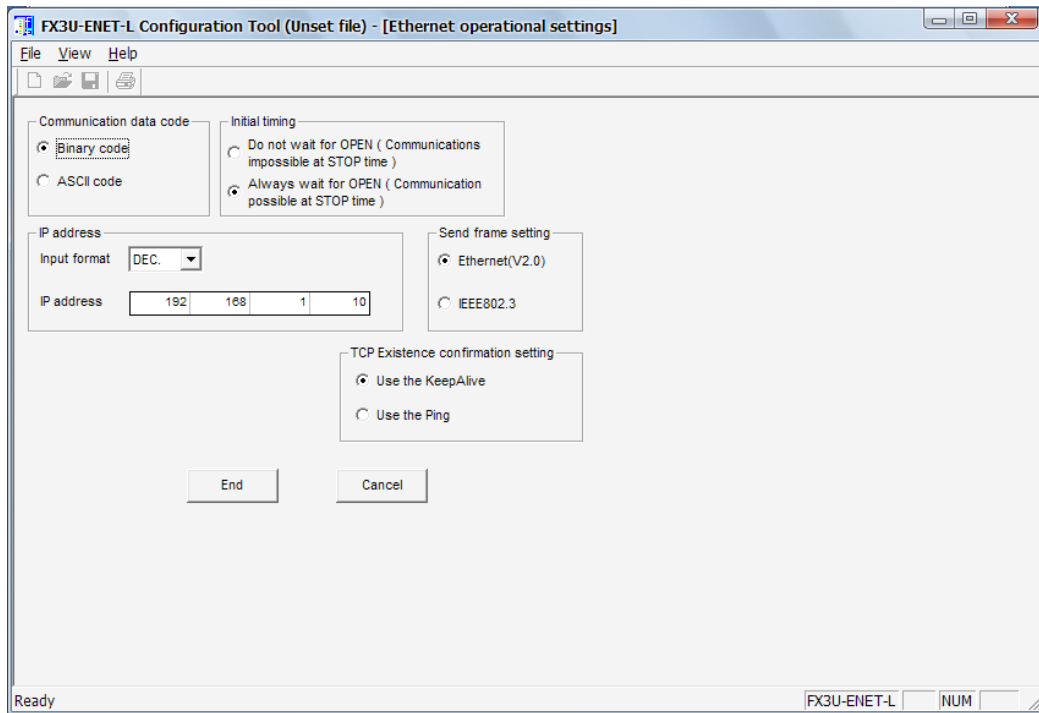

3. Select "open Settings", double click the left mouse button to open the window as shown below, select "TCP" as the protocol, select "MC Protocol" as the opening method, and set the port number of this site:

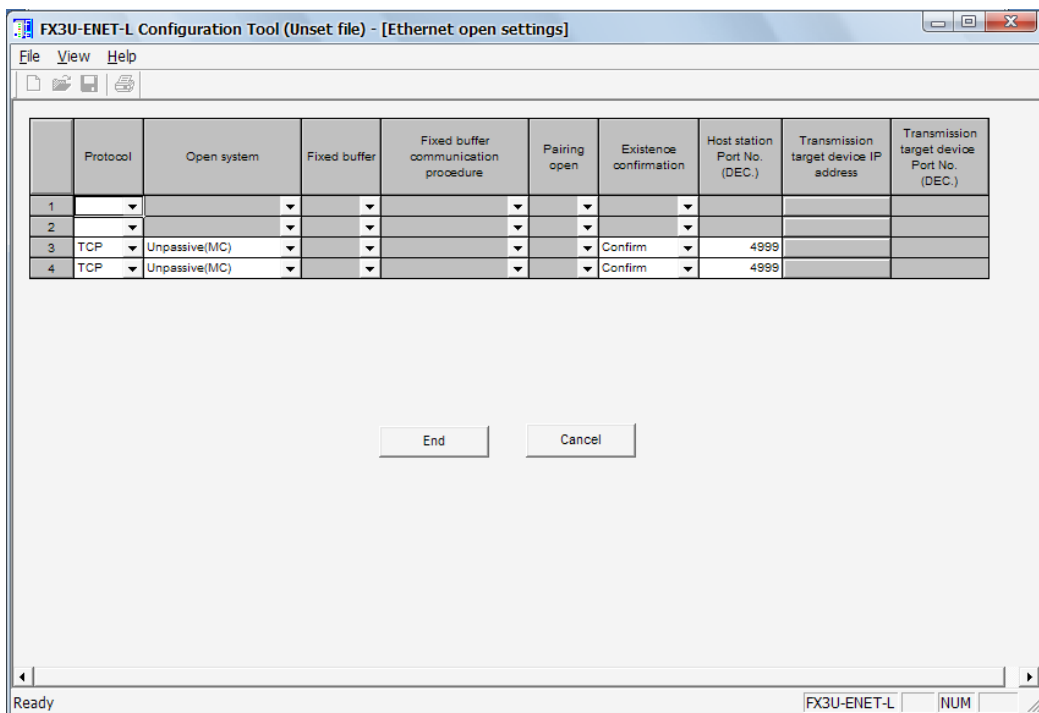

4. Select "Router relay parameter" and double click the left mouse button to open the following window to set the subnet mask and default gateway of the site:

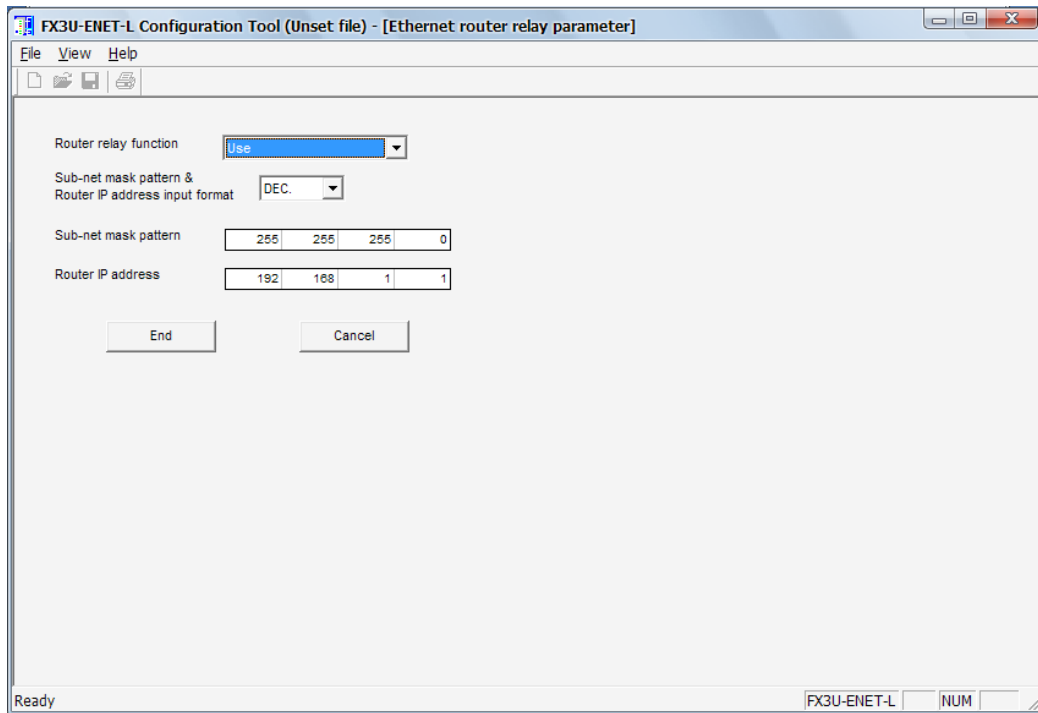

HMI settings

(a) Choose the HMI type TN(-ET), TG(-ET) or TE(-ET), click next, choose Net device in the list, please input the HMI IP address in the own devices.

System Settings

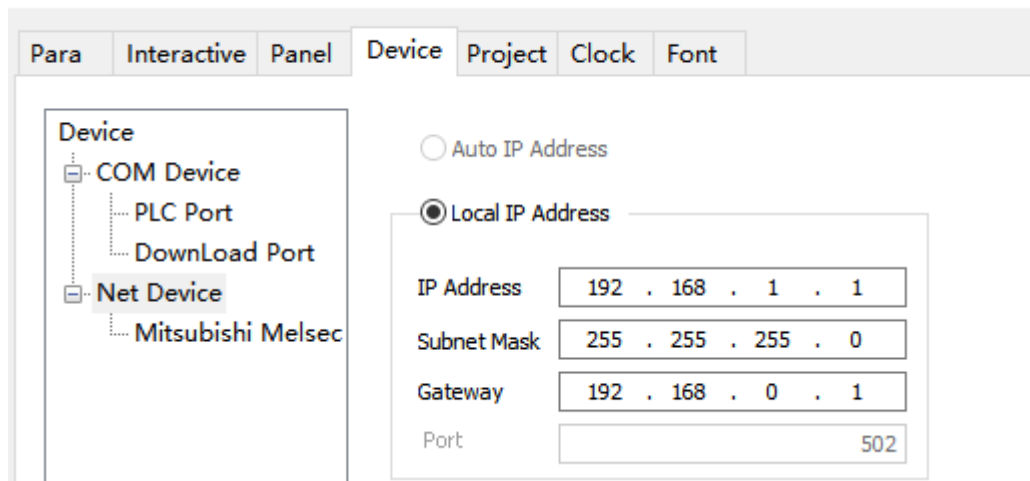

(b) Choose the net device, right click it, choose new, and name it as Mitsubishi Melsec(1E).

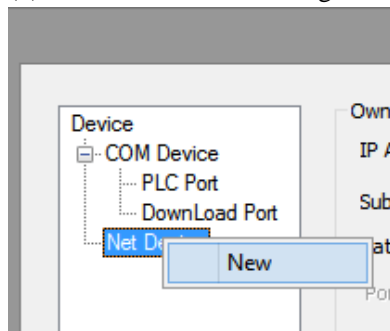

(c) Set the local IP address of HMI and set the touch screen address to the same network segment as the PLC and cannot be the same as the PLC IP address, such as 192.168.1.11.

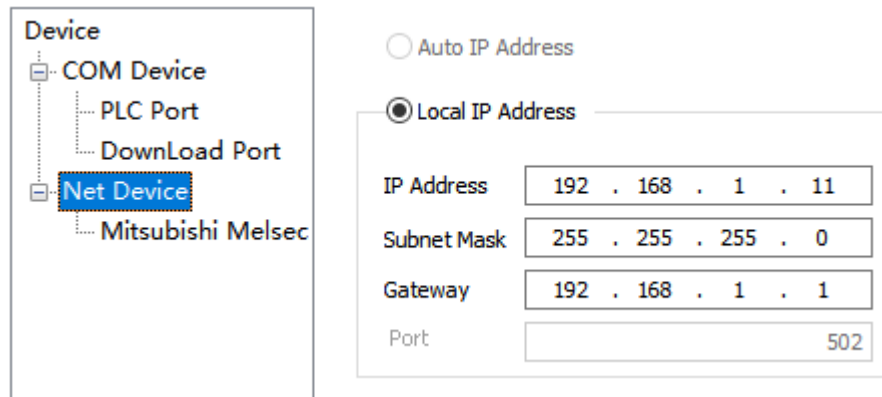

(d) Select "Mitsubishi MELSEC (1E) protocol" in the equipment list. This IP address is the IP address of Mitsubishi PLC, and the port number is the "local port number" (decimal) set in PLC software:

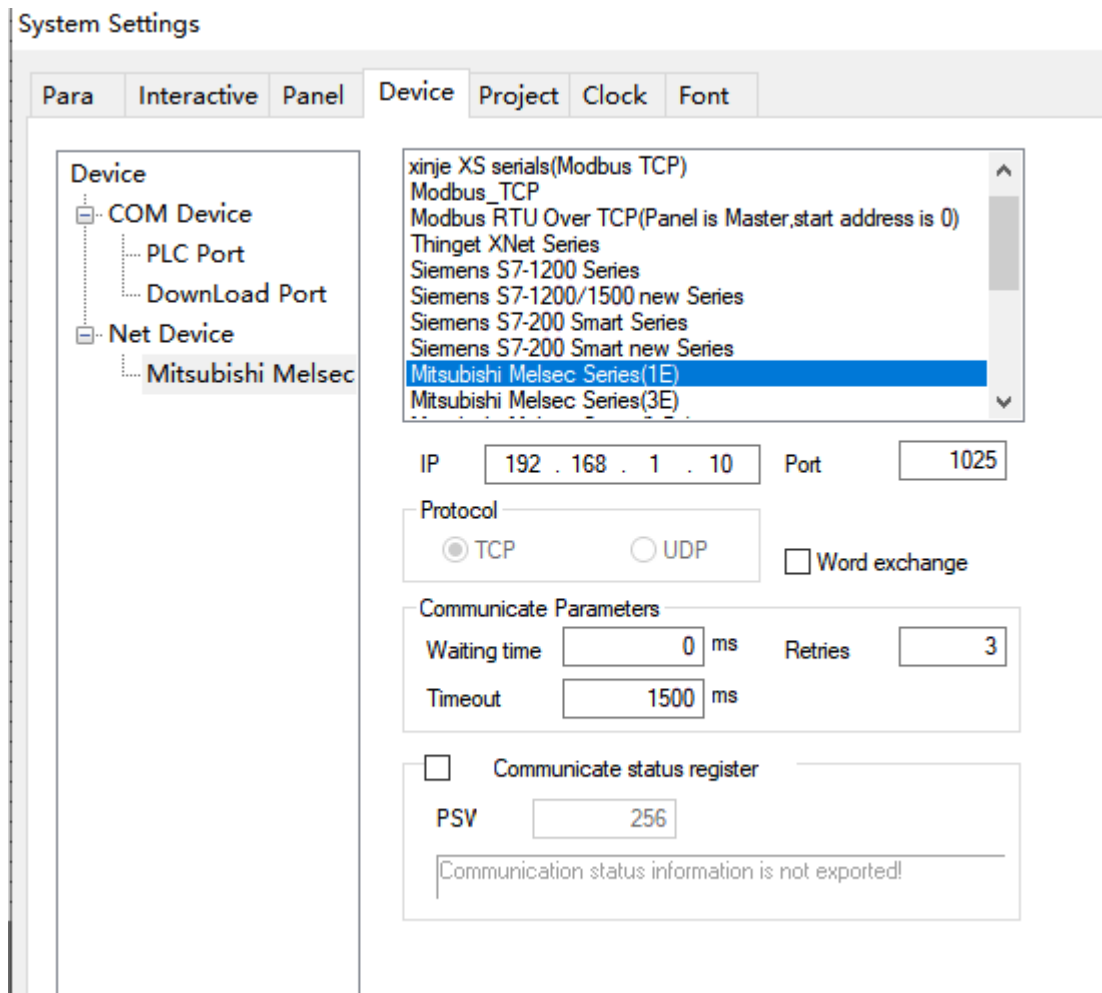

(e) Please keep the communication parameters as default, if the communicate status register is selected, PSW256~PSW259 respectively indicate communication successful times, failed times, overtime times, error times. User can set the register address as needs.

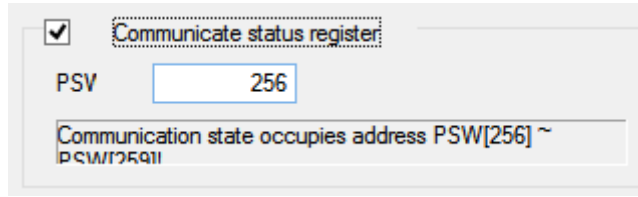

(f) Click next to finish the settings and enter screen edit interface. Put a data input button on the screen, and choose the Mitsubishi melsec(1E) in the device list.

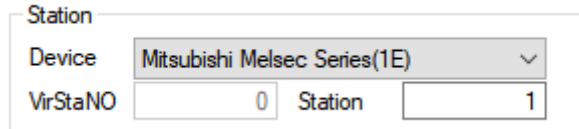

2.41.3 Cable making

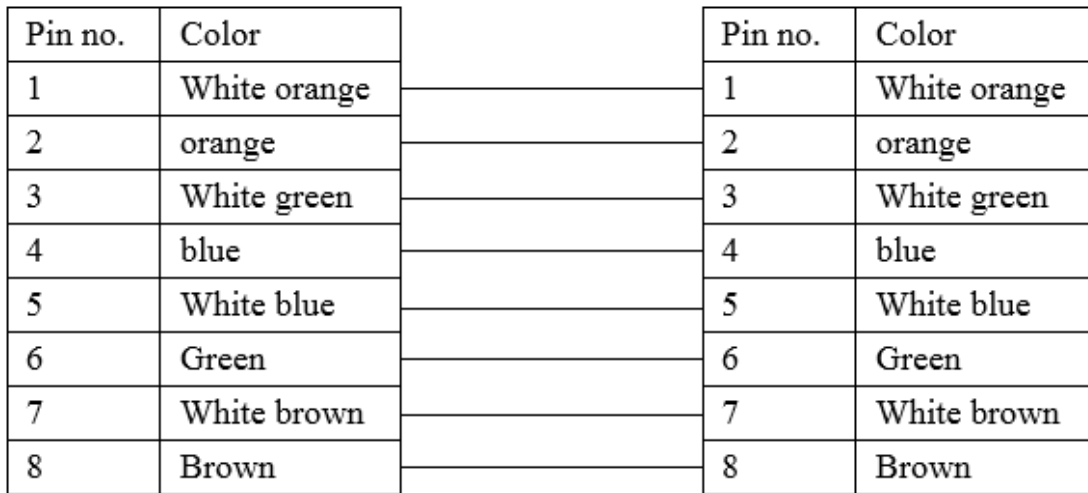

Fig 1

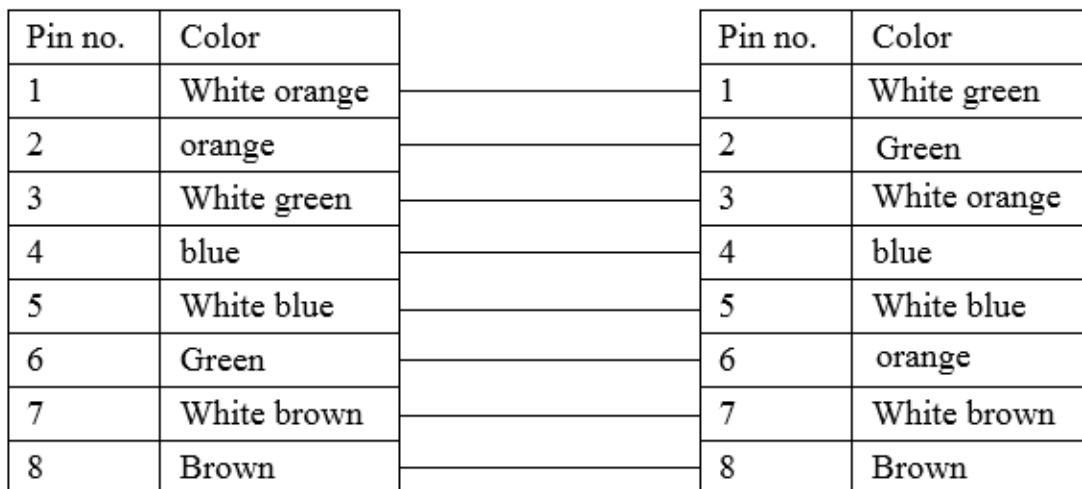

Fig 2

2.41.4 Device address

PLC address	Range	Object type	Explanation
X	0~377	Bit	Input
Y	0~377	Bit	Output
M	0~8511	Bit	Internal auxiliary relay
CS	0~255	Bit	Counter relay
TS	0~511	Bit	Timer relay
S	0~4095	Bit	Status relay
D	0~8511	Bit	Data register
R	0~32767	Bit	Extended register
TN	0~511	Bit	Timer present value
CN	0~199	Bit	16-bit counter
LCN	200~255	Bit	32-bit counter

2.42 Mitsubishi Melsec 3E(Ethernet) series PLC

2.42.1 Device type

Series	Port	Cable	PLC model in Touchwin software
Mitsubishi L series Mitsubishi Q series	RJ45	Fig 1 or 2	Mitsubishi Melsec series(3E)

2.42.2 Parameter settings

Take Mitsubishi L series PLC as an example to explain the Melsec(3E) protocol device parameter settings.

1. PLC software settings

Select project area-PLC parameter-Ethernet terminal setting, set the PLC IP address. The communication data code please set to binary code communication. Select “permit write (FTP & MC protocol) when running.



click “open the setting”, select “TCP” protocol and “MC” open mode, and set the station port no. (range is 0401H~1387H, 1392H~FFFEH).



Note: In the network parameter setting of L series network module, the initial time shall be always open wait.

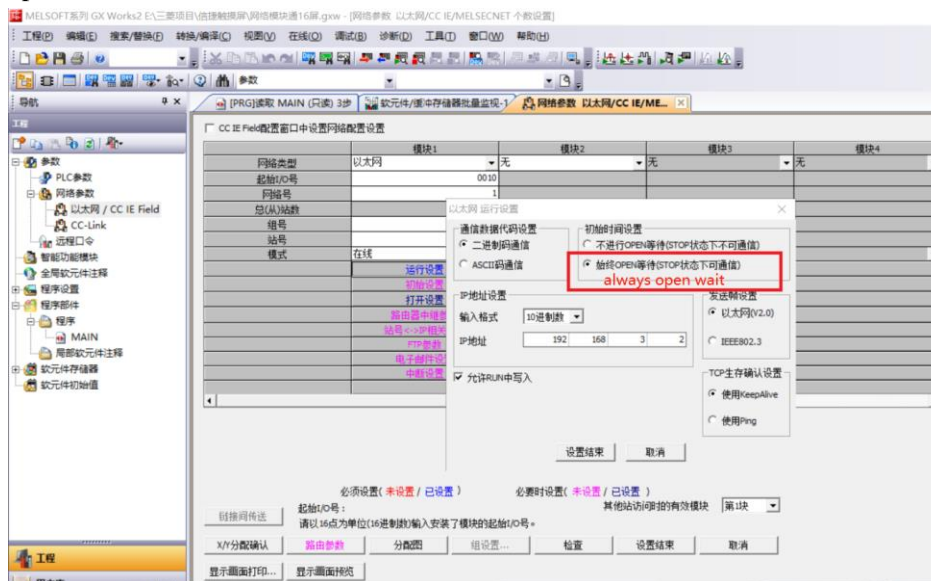

2.HMI setting

Please select the HMI type, click next.

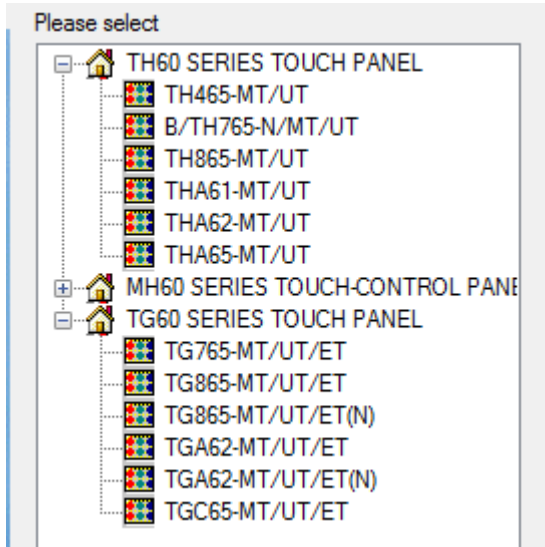

Select Net device. The IP address in own devices is HMI IP address.

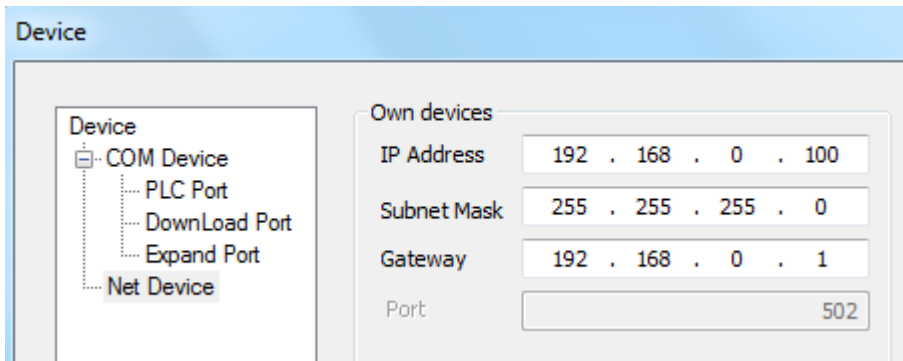

Right click Net device, click New. Then input the project name.

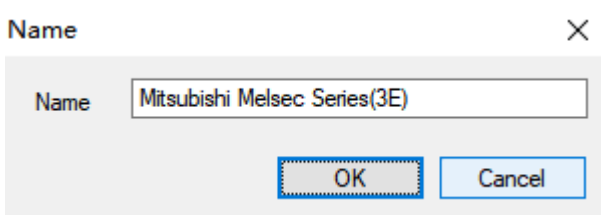
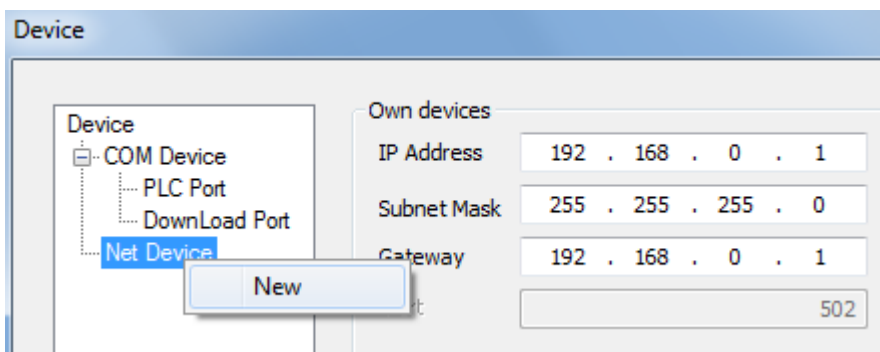

Select Mitsubishi Melsec series(3E) in the device list. The IP address is Mitsubishi PLC IP address, the port 1025 is the station port no. setting in the Mitsubishi PLC.

Device

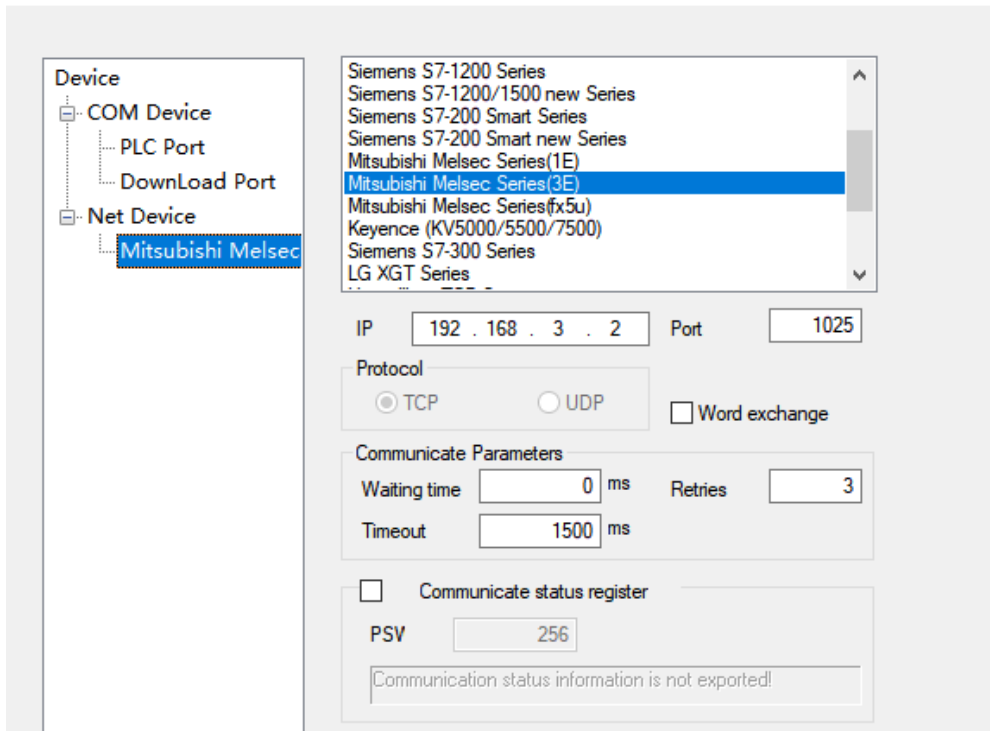

Communication parameters: please use the default parameters. Communication status register: if select this item, the status will occupy 4 registers. The register address can be set by user. If set the address to PSW256, the register meanings are shown as the following.

- PSW256: communication succeeded times
- PSW257: communication failed times
- PSW258: timeout times
- PSW259: communication error times.

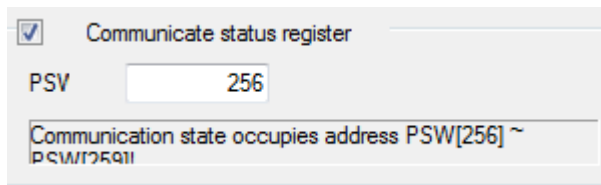

Then click next to finish the project setup.

In the editing screen, when user defines the button object, please select Mitsubishi Melsec Series(3E).

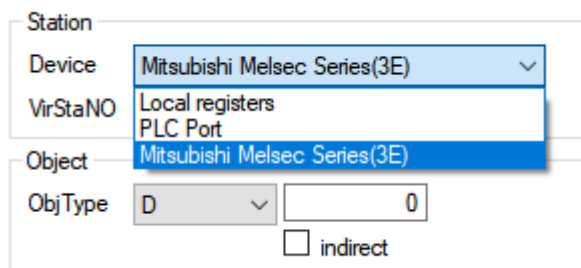

2.42.3 Cable making

RJ45 straight through cable (connect HUB) or RJ45 crossover cable:

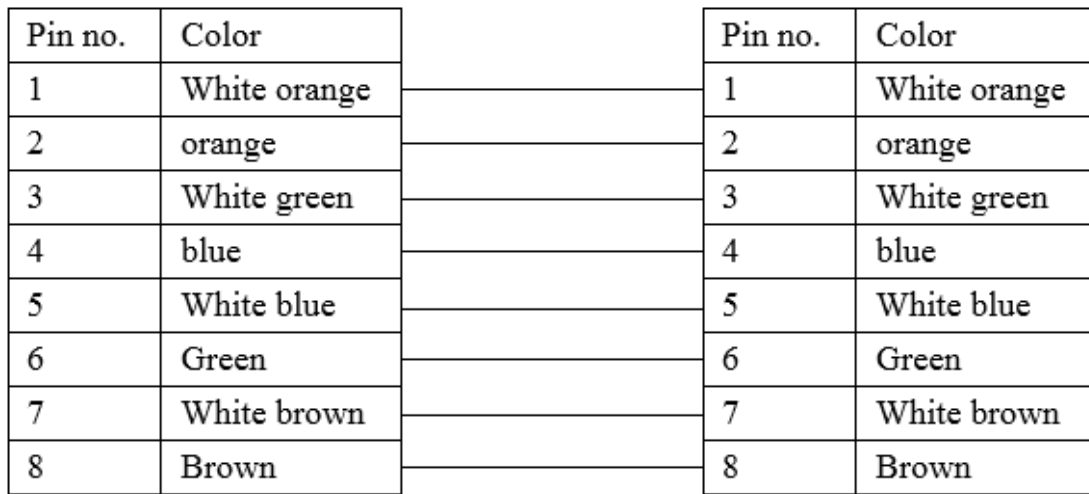

Fig 1

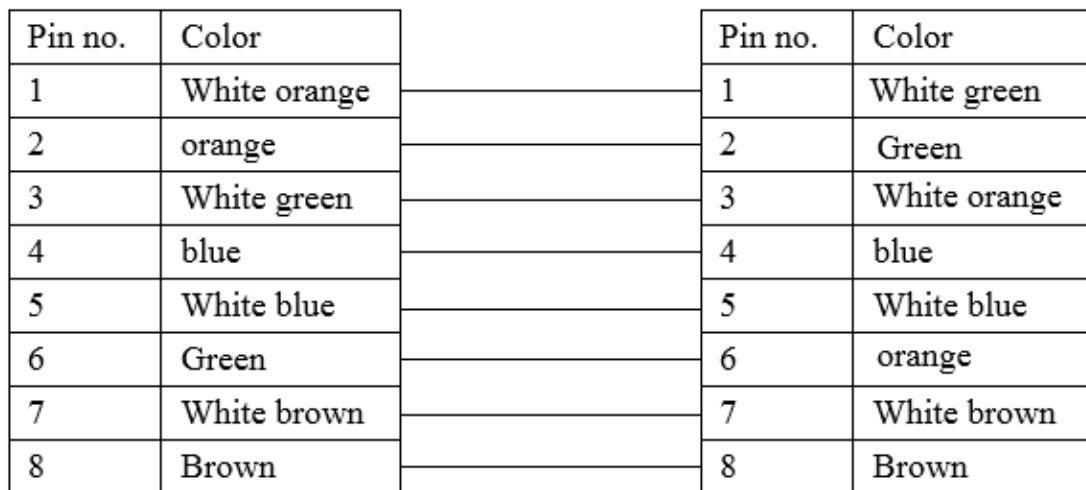

Fig 2

2.42.4 Device address

PLC address	Range	Object type	Explanation
X	0~1fff	Bit	Input
Y	0~1fff	Bit	Output
M	0~8191	Bit	Internal auxiliary relay
L	0~8191	Bit	Lock relay
F	0~2047	Bit	Alarm relay
V	0~2047	Bit	Variable address relay
B	0~1fff	Bit	Link relay
TS	0~2047	Bit	Timer relay

SS	0~2047	Bit	Holding delay timer relay
CS	0~1023	Bit	Counter relay
SB	0~7ff	Bit	Special link relay
S	0~2047	Bit	Stepper relay
SM	0~2047	Bit	Special relay
D	0~65535	Word/DWord	Data register
W	0~1fff	Word/DWord	Link register
TC	0~2047	Word/DWord	Timer coil
TN	0~2047	Word/DWord	Timer present value
SC	0~2047	Word/DWord	Holding delay timer coil
SN	0~2047	Word/DWord	Holding delay timer present value
CC	0~1023	Word/DWord	Counter coil
CN	0~1023	Word/DWord	Counter coil
SW	0~7ff	Word/DWord	Special link register
SD	0~2047	Word/DWord	Special register
Z	0~19	Word/DWord	Variable address register

2.43 Mitsubishi SLMP FX5U(Ethernet) series PLC

2.43.1 Device type

Series	Communication type	Cable	PLC model in Touchwin software
Mitsubishi FX5U series	RJ45	Fig1 or Fig2	Mitsubishi FX5U series

2.43.2 Parameters

PLC software settings

1. Open the engineering area parameters---PLC parameters---built-in Ethernet port setting interface, set the PLC IP address, set the communication data code to "binary code communication", and check "write in run (FTP and MC protocol)", as shown in the following figure:

2. Select "open setting" and click the left mouse button to open the window as shown below. Select "TCP" as the protocol, select "MC Protocol" as the opening method, and set the port number of the station (setting range: 0401H~1387H, 1392H~FFFEH):

FX5U series

(a) Click: Navigate - Parameters - FX5UCPU - Module - Ethernet port, set the IP address of the PLC and the gateway. In this case, set the IP address of the PLC to 192.168.3.251

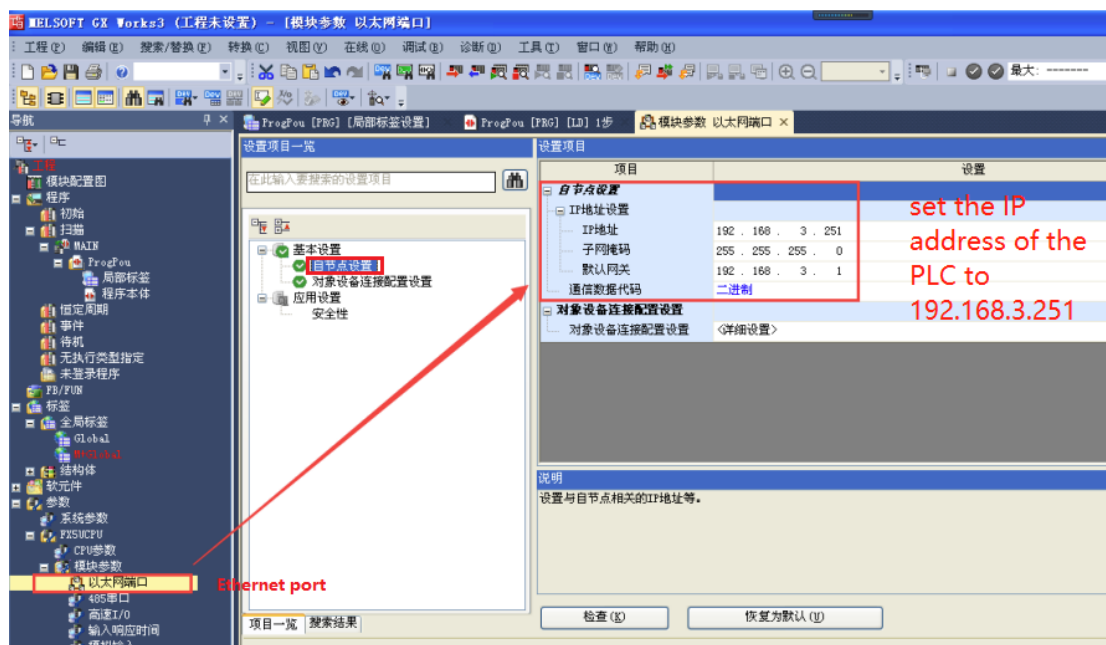

(b) Click Detailed Settings, select Ethernet Devices (General) -SLMP connected devices in the right window,

and drag and drop directly to the network configuration interface. The IP address is the respective address of PLC, and the default port number is 4999. Save it and download it to PLC. Select PLC parameters when downloading.

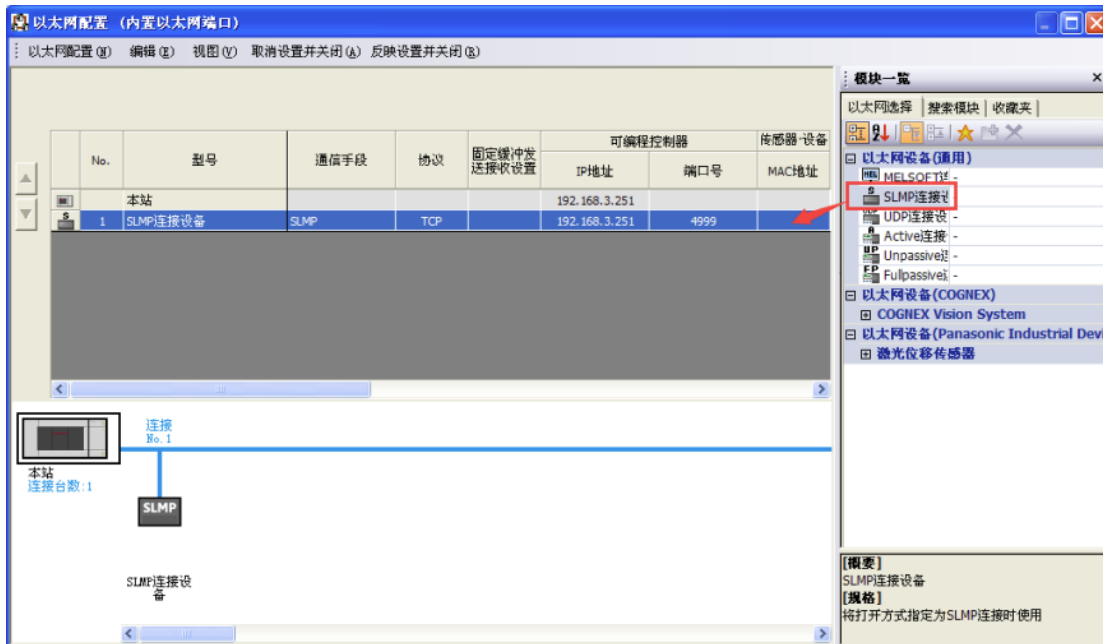

HMI setting

(a) set the HMI model to TN (-ET), TG (-ET), or TE (-ET), and click Next. In the Device list, select Net Device. In 'Local IP Address', set the IP address of the HMI, as long as it does not conflict with other IP addresses on the network.

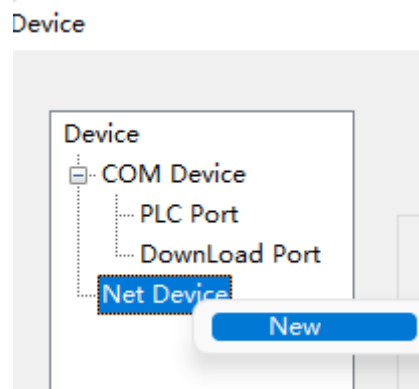

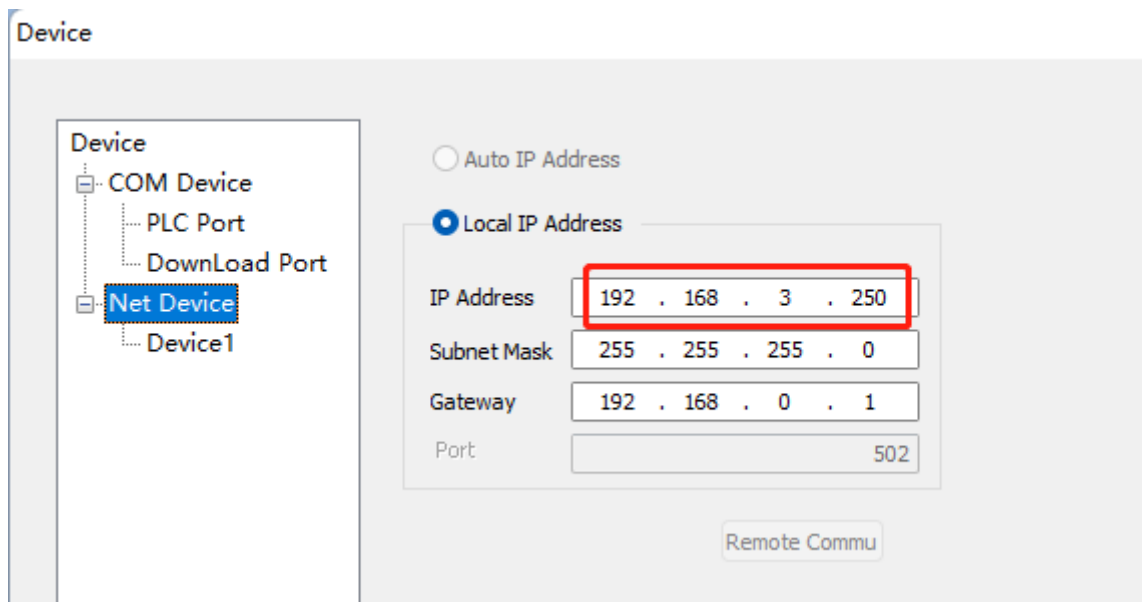

(b) Select "Mitsubishi SLMP (FX5U) " from the equipment list. This IP address is the IP address of Mitsubishi PLC, and the port number is the "Port number of this site" set in PLC software (decimal).

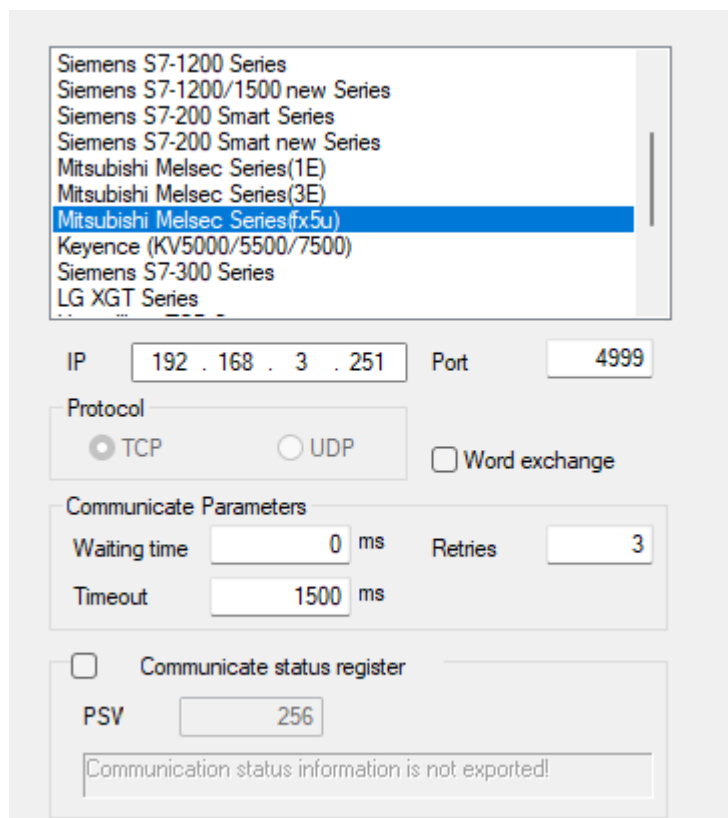

(c) Please keep the communication parameters as default, if the communicate status register is selected, PSW256~PSW259 respectively indicate communication successful times, failed times, overtime times, error times. User can set the register address as needs.

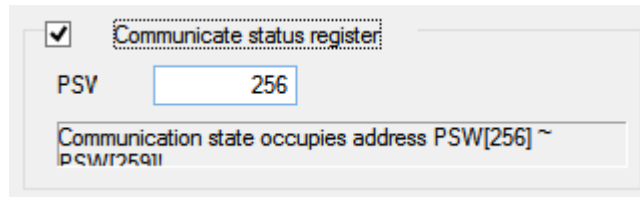

(d)Click next to finish the settings and enter screen edit interface. Put a data input button on the screen, and choose the Mitsubishi melsec series(fx5u)in the device list.

2.43.3 Cable making

RJ45 Straight Through Cable (HUB) or Crossover Cable (Crossover Cable)

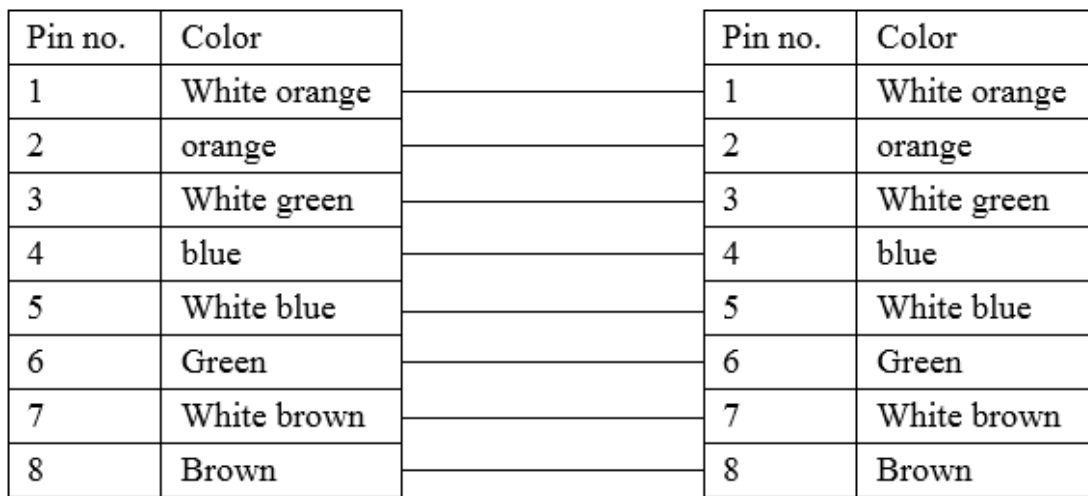

Fig 1

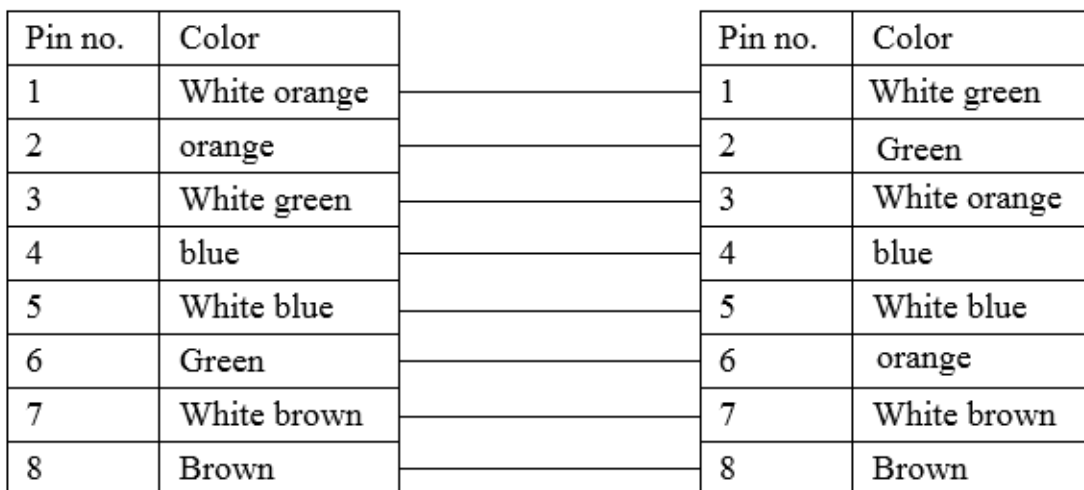

Fig 2

2.43.4 Device address

PLC address type	Range	Object type	Explanation
X	0~1fff	Bit	Input
Y	0~1fff	Bit	Output
M	0~8191	Bit	Internal auxiliary relay
L	0~8191	Bit	Locking relay
F	0~2047	Bit	Alarm
V	0~2047	Bit	Variable address relay
B	0~1fff	Bit	Linkage relay
TS	0~2047	Bit	Timer contactor
SS	0~2047	Bit	Accumulated timer contactor
CS	0~1023	Bit	Counter contactor
SB	0~7fff	Bit	Internal special linkage relay
S	0~2047	Bit	Step relay
SM	0~2047	Bit	Internal special step relay
D	0~65535	Word/DWord	Data register
W	0~1fff	Word/DWord	Linkage register
TC	0~2047	Bit	Timer coil
TN	0~2047	Word/DWord	Timer
SC	0~2047	Bit	Accumulated timer coil
SN	0~2047	Word/DWord	Accumulated timer
CC	0~1023	Bit	Counter coil
CN	0~1023	Word/DWord	Counter
SW	0~7fff	Word/DWord	Internal special linkage register
SD	0~2047	Word/DWord	Internal special register
Z	0~19	Word/DWord	Variable register

2.44 Modbus ASCII (Panel is Master)

2.44.1 Device type

Series	Port	Cable	PLC model in Touchwin software
The device support Modbus ASCII protocol	RS485	Fig 1	Modbus ASCII (Panel is Master)
	RS232	Fig 2	
	RS422	Fig 3	

2.44.2 Parameters

HMI

Parameters	Recommend settings	Choices of settings	Note
PLC type	Modbus ASCII (panel is Master)		
Port	RS485	RS485/RS232/RS422	
Data bit	7	7 or 8	
Stop bit	1	1 or 2	
Parity	Even parity	Even/odd/no parity	
Baud rate	9600	4800/38400/9600/115200/19200/187500	
Station no.	1	0~255	

PLC:

Please choose Modbus ASCII (Slave) protocol in the software.

2.44.3 Cable making

Modbus RS485:

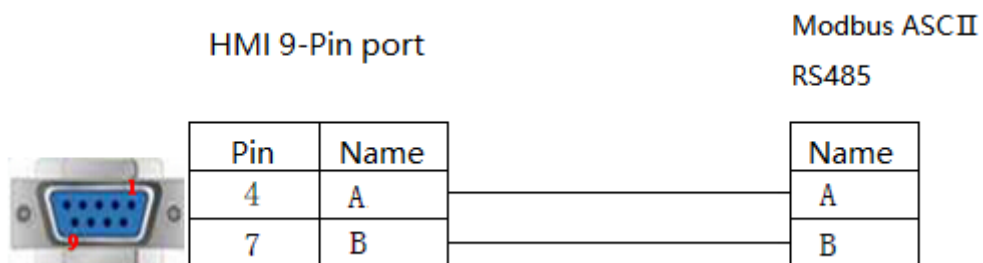

Fig1

Modbus RS232:

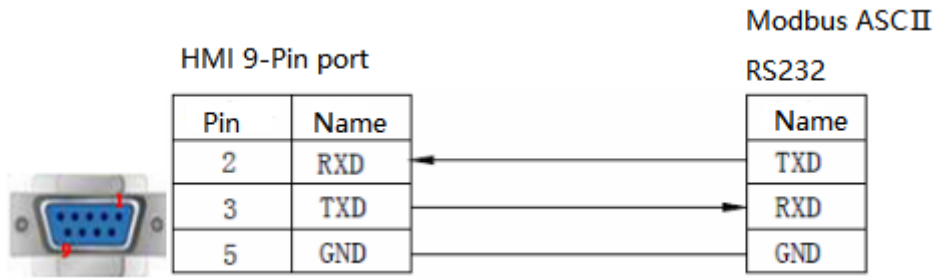

Fig2

Modbus RS422:

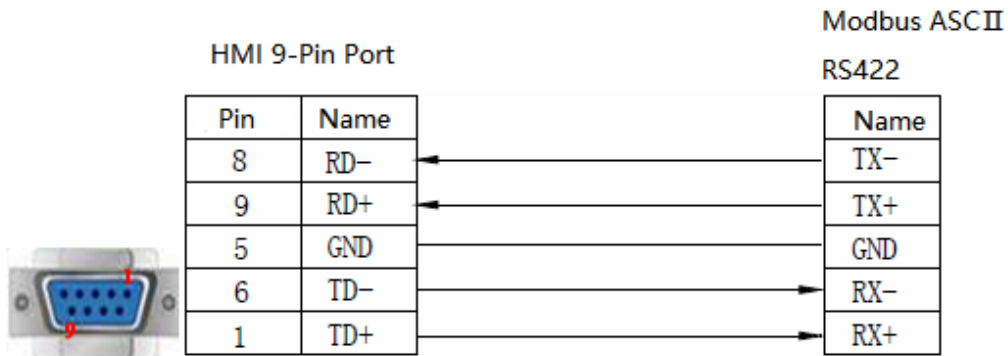

Fig3

2.44.4 Device address

Device address	Range	Data type	Explanation
0x	0~65535	Bit	External I/O/internal coil
1x	0~65535	Bit	External I/O/internal coil
4x	0~65535	Word/Dword	Used as data register
3x	0~65535	Word/Dword	Used as data register

2.45 Modbus RTU (Panel is Master)

2.45.1 Device type

Series	Port	Cable	PLC model in Touchwin software
Devices support Modbus RTU protocol	RS485	Fig 1	Modbus RTU (Panel is Master)
	RS232	Fig 2	
	RS422	Fig 3	

2.45.2 Parameters

HMI:

Parameters	Recommend settings	Choices of settings	Note
PLC type	Modbus RTU (panel is Master)		
Port	RS485	RS485/RS232/RS422	
Data bit	8	7 or 8	
Stop bit	1	1 or 2	
Parity	Even parity	Even/odd/no parity	
Baud rate	9600	4800/38400/9600/115200/19200/187500	
Station no.	1	0~255	

Note:

1. Modbus RTU protocol supports broadcast function, station no is 0.
2. Using the broadcast function in the touch screen: the broadcast function only sends command but not receives. It sends command by “function field”, “function button” or “function block” in Touchwin software. The operand must has no feedback command, such as “set on coil”, “setting data”, “reset coil”.

PLC:

Please choose Modbus RTU (Slave) in the software.

2.45.3 Cable making

(a) Modbus RS485:

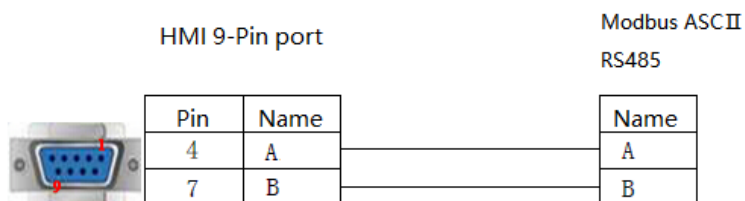

Fig1

(b) Modbus RS232:

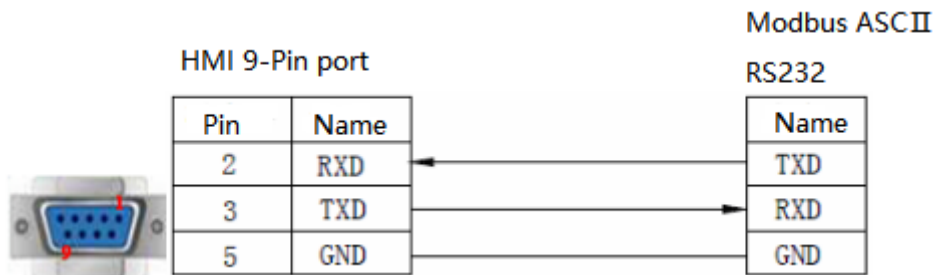

Fig2

(c) Modbus RS422:

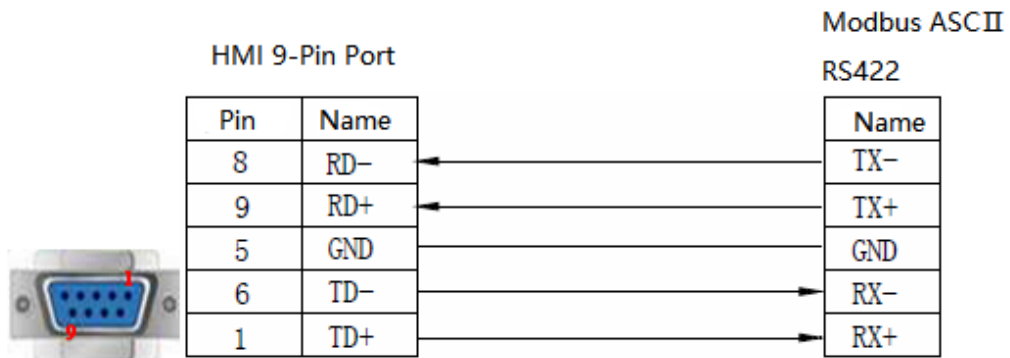

Fig3

2.45.4 Device address

Device address	Range	Data type	Feature	Explanation
0x	0~65535	Bit	R/W	External I/O /internal coil
1x	0~65535	Bit	R	External I/O /internal coil
4x	0~65535(0~15)	Bit	R/W	External I/O /internal coil
4x	0~65535	Word/Dword	R/W	Used as data register
3x	0~65535	Word/Dword	R	Used as data register

2.46 Modbus RTU (Panel is Slave)

2.46.1 Device type

Series	Port	Cable	PLC model in Touchwin software
The device support Modbus protocol	RS485	Fig 1	Modbus slave (Panel is Slave)
	RS232	Fig 2	
	RS422	Fig 3	

2.46.2 Parameters

HMI:

Parameters	Recommend settings	Choices of settings	Note
PLC type	Modbus slave (panel is slave)		
Port	RS485	RS485/RS232/RS422	
Data bit	8	7 / 8	
Stop bit	1	1 / 2	
Parity	Even parity	Even/odd/no parity	
Baud rate	9600	4800/38400/9600/115200/19200/187500	
Station no.	1	0~255	

2.46.3 Cable making

Modbus RS485:

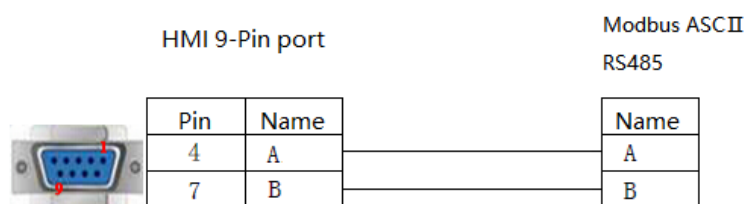

Fig1

Modbus RS232:

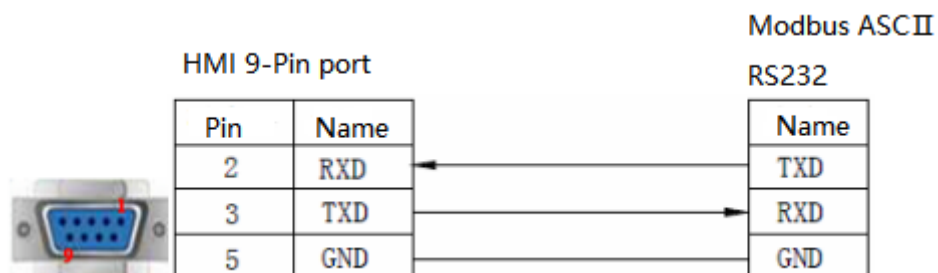

Fig2

Modbus RS422:

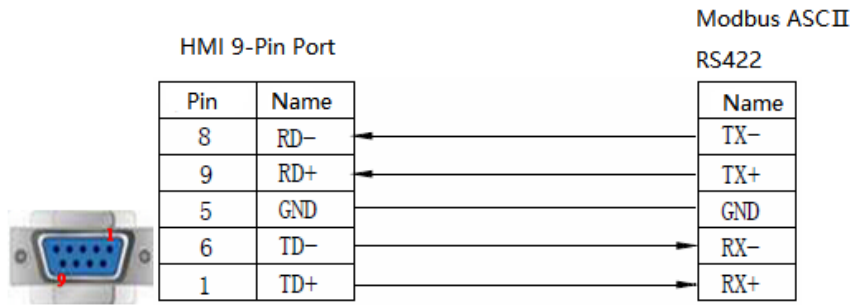

Fig3

2.46.4 Device address

Device address	Range	Data type	Features	Explanation
PSB	256~1023	Bit	R/W	256~1023
PSW	256.00~8191.15	Bit	R/W	256.00~8191.15
PFW	256.00~64535.15	Bit	R/W	10256.00~64535.15
PSW	256~8191	Word/Dword	R/W	256~8191
PFW	256~55535	Word/Dword	R/W	10256~65535
PSB	256~1023	Bit	R/W	256~1023

a. The internal objects of the touchwin screen include PSB, PSW and PFW:

objects	Explanation
PSB	Represent bit object
PSW	Represent non outage hold word object
PFW	Represent power failure hold word object

b. Range of internal objects available for each model:

model	TH465	TH series	TG/TN series
object	256~1023		
PSB	256~1023		
PSW	256~8191		
PFW	8M-Picture occupation, System occupancy	256~246015	256~4000000

c. Use of special address inside the touch screen

The address range 0~255 of internal objects of PSW, PFW and PSB is used as a special function of the system.

2.47 Modbus-TCP device

2.47.1 Device type

Series	Port	Cable making	PLC model in Touchwin software
Ethernet device supporting Modbus TCP protocol	RJ45	Fig1 or Fig 2	Modbus TCP

2.47.2 Parameter setting

Take Xinje XD5E as an example to explain the Modbus TCP parameter setting.

PLC settings

connect the PLC to the computer, open the PLC programming software, open the PLC configuration in the engineering column on the left side of the software, double-click the “Ethernet port” below, manually set the Ethernet parameters of PLC in the pop-up configuration window, and click “write to PLC” after setting:

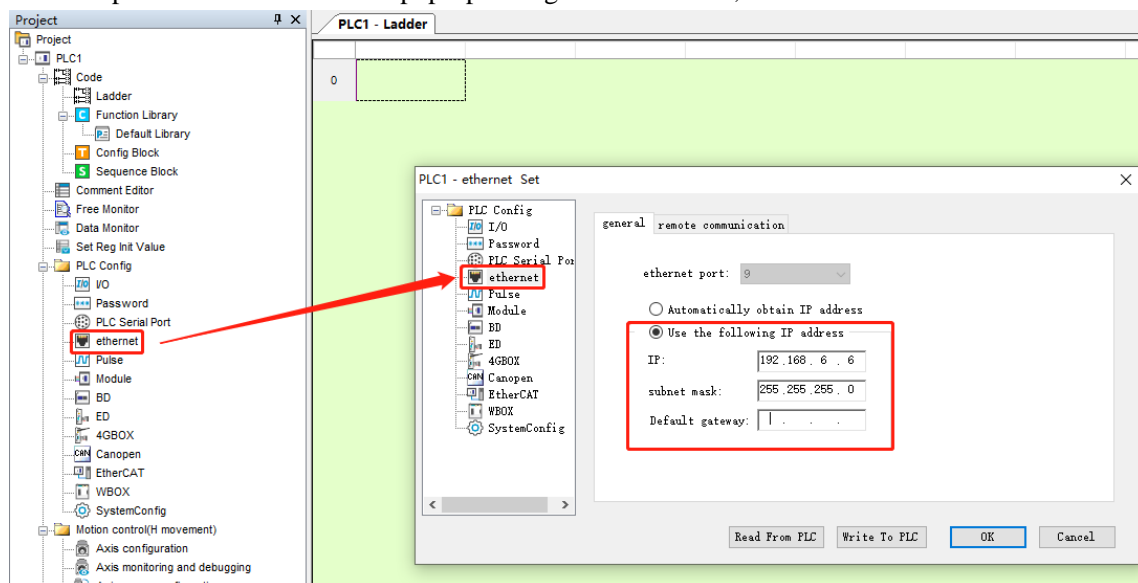

Note: After the parameter is written, the PLC needs to be restarted to take effect.

HMI settings

After selecting the human-machine interface model as TN(-ET),TG(-ET) or TE(ET), click next, and select “Net device” in the device list. In Local IP address: the IP address ,as long as it does not conflict with other IP address in the network.

Local IP Address

IP Address: 192 . 168 . 6 . 1

Subnet Mask: 255 . 255 . 255 . 0

Gateway: 192 . 168 . 6 . 1

Port: 502

Right click net device, build a new Ethernet device.

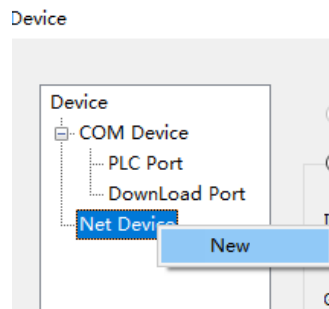

Select “Modbus_TCP” in the equipment list. This IP address is the IP address of XD5E, and the port number is 502 by default. It cannot be modified:

xinje XD/XG serials
 xinje XS serials(Modbus TCP)
 Modbus_TCP
 Modbus RTU Over TCP(Panel is Master,start address is 0)
 Thinget XNet Series
 Siemens S7-1200 Series
 Siemens S7-1200/1500 new Series
 Siemens S7-200 Smart Series
 Siemens S7-200 Smart new Series
 Mitsubishi Melsec Series(1E)

IP: 192 . 168 . 0 . 1 Port: 502

Protocol: TCP UDP Word exchange

Communicate Parameters

Waiting time: 0 ms Retries: 3

Timeout: 1500 ms

Communicate status register

PSW: 256

Communication status information is not exported!

The communication parameters please keep defaulted. If selecting communicate status register, the PSW256~PSW259 represents communicate successful times, communication failure times, communication overtime times, communication error times. User can change the PSW address.

Communicate Parameters

Waiting time ms Retries

Timeout ms

Communicate status register

PSV

Communication state occupies address PSW[256] ~
P5W/P75911

Click next to finish the setting. Then enter the editing screen, put a data input button on the screen, select “device 1”, the object type includes 4x(read and write, word object), 3x(read only, word object), 0x(bit object, read and write), 1x(read only, bit object).

Data Input

Object Display Convert Inputs Font Color Position

Operate Object

Station

Device

VirStaNO Station

Object

ObjType

indirect

Value

Data Type

Download the program in the HMI. Then the touch screen can control remote PLC and other equipment through Ethernet.

2.47.3 Cable making

RJ45 straight through cable (connect HUB) or RJ45 crossover cable:

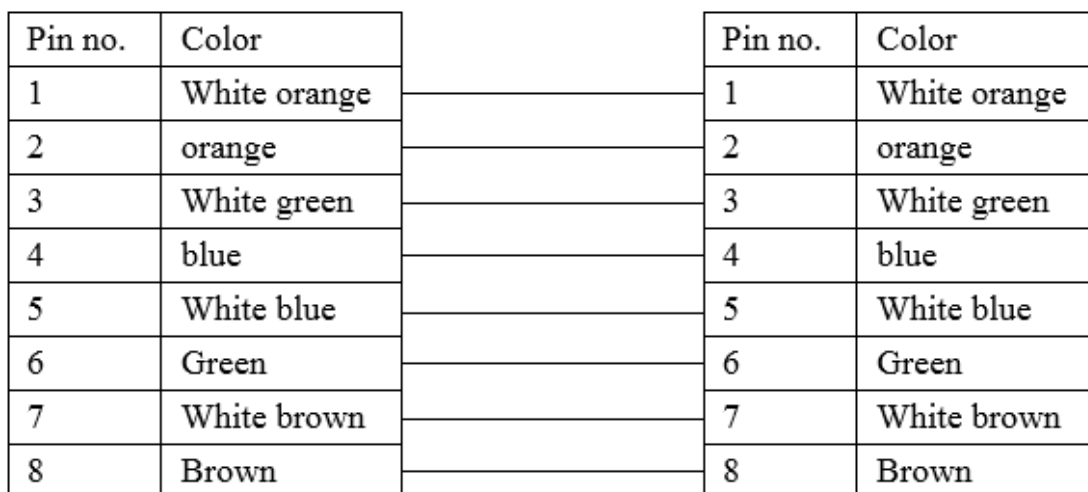

Fig 1

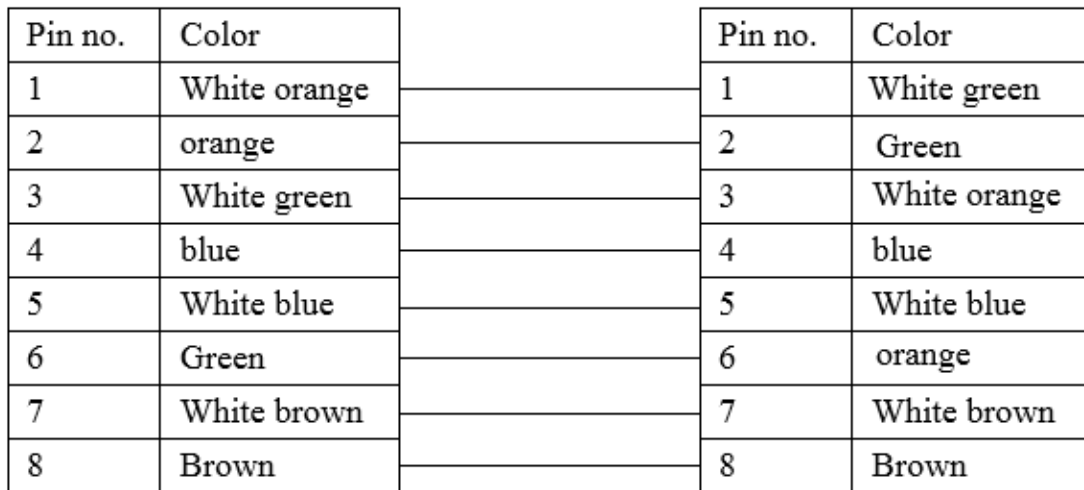

Fig 2

2.47.4 Device address

Address	Range	Object type	property	Notes
0x	0~65535	Bit	R/W	I/O internal coil
1x	0~65535	Bit	R	I/O internal coil
4x	0.00~65535.15	Bit	R/W	I/O internal coil
4x	0~65535	Word/Dword	R/W	Data register
3x	0~65535	Word/Dword	R	Data register

2.48 OEMax NX7 series PLC

2.48.1 Device type

Series	CPU	Connected module	Port	Cable	PLC model in Touchwin software
NX7	NX7	COM0 port	RS232	Fig 1	OEMax NX7 Series PLC
			RS232	Fig 2	
		COM1 port	RS485	Fig 3	
			RS232	Fig 4	

2.48.2 Device address

HMI:

Parameter	Recommend settings	Choices of settings	Note
PLC type	OEMax NX70 series PLC		
Port	RS232	RS232/RS485	
Data bit	8	7 or 8	
Stop bit	1	1 or 2	
Parity	No parity	Even/odd/no parity	
Baud rate	9600	4800/38400/9600/115200 /19200/187500	
Station no.	1	0~255	

The default parameters of OEMax NX7 PLC: 9600, 8, 1, no parity, station no.1.

2.48.3 Cable making

(a) OEMax NX7 PLC COM1 (RS232):

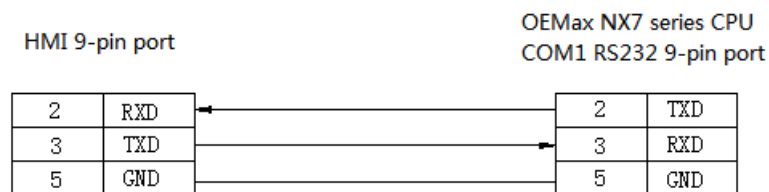

Fig1

(b) OEMax NX7 PLC COM1 (RS485):

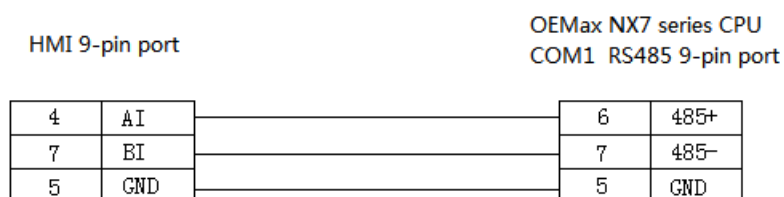

Fig2

(c) OEMax NX7 PLC COM2 RJ-45 (RS232):

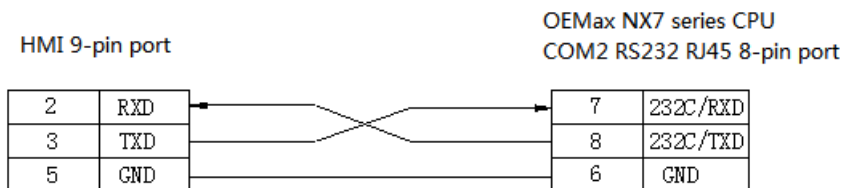
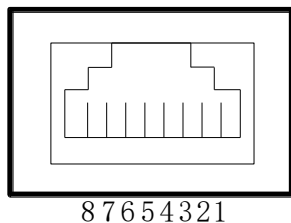

Fig3

(d) OEMax NX7 PLC COM2 is RJ-45 8-pin port, short pin1 and 3 means RS485+, short pin2 and 4 means RS485- :

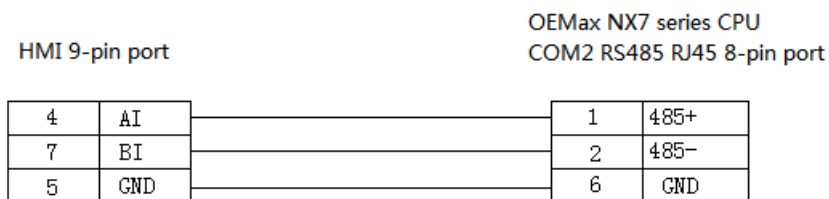

Fig4

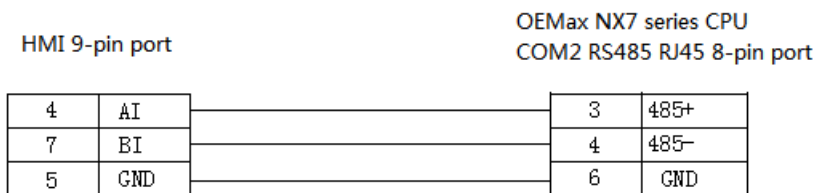

Fig5

2.48.4 Device address

PLC address	Range	Data type	Explanation
R	R000.00~R31.15	Bit	External I/O coil
	R32.00~R127.15	Bit	Special coil
L	L000.00~L063.15	Bit	Internal coil
M	M000.00~M127.15	Bit	Internal auxiliary coil
K	K000.00~K127.15	Bit	Internal holding coil
F	F000.00~F015.15	Bit	Special coil
TC	TC0~TC255	Bit	Timer /counter coil

W	0~6000	Word/DWord	Data register
R	0~127	Word/DWord	Used as register
L	0~63	Word/DWord	Used as register
M	0~127	Word/DWord	Used as register
K	0~127	Word/DWord	Used as register
F	0~15	Word/DWord	Used as register
SV	0~255	Word/DWord	Timer/counter settings
PV	0~255	Word/DWord	Timer/counter current value
SR	0~511	Word/DWord	Special register

2.49 OMRON SYSMAC CP series PLC

OMRON CPM1A, CQM1-CPU series CPU cannot support RS232. It can connect to the Touchwin HMI via CPM1-CIF01 adapter and modules including C500-LK203, C120-LK201-V1, C500-LK201-V1. The PLC uses Hostlink protocol when communicating. Please change the PLC startup choice to MONITOR RUN.

2.49.1 Device type

1.OMRON CP/CJ/CS series

Series	CPU	Connected module	Port	Cable	PLC model in Touchwin software
CP	CP1E-30N CP1H CP1L	CPU direct connection	RS232	Fig 1	Omron CP/CJ/CS
		Module CP1W-CIF11	RS485	Fig 2	
		Module CP1W-CIF11	RS422	Fig 3	
CJ	CJ1 CJ1G-CPU44 CJ1G-CPU45 CJ2M-CPU11	CPU direct connection	RS232	Fig 1	
CS1	CS1H-CPU63/64/65/66/67 CS1G-CPU42/43/44/45 CS1G-CPU42H CS1G-CPU43H CS1G-CPU44H CS1G-CPU45H CS1H-CPU63H CS1H-CPU64H CS1H-CPU65H CS1H-CPU66H CS1H-CPU67H	CPU direct connection	RS232	Fig 1	

2.OMORN CPM/CQM series

Series	CPU	Connected module	Port	Cable	The PLC device in TouchWin
C	C200HE C200HX	CPU direct connection	RS232	Fig 1	Omron CPM/CQM
	C1000HF	C500-LK203 (communication module)			
	C2000	C120-LK201-V1(communication module)			

		C500-LK201-V1(communication module)		
		C500-LK203(communication module)		
CPM	CPM2A CPM2AE CPM2AH-40CDR-A CPM1H	CPU direct connection	RS232	Fig 1
	CPM1A	OMRON CIF01 (RS232) Communication adapter		
CQM	CQM1H-CPU21	CPU direct connection		
	CQM1-CPU	OMRON CIF01 (RS232) Communication adapter		

Note:Omron CPM1A and CQM1-CPU series units do not support RS232 serial port communication. They can communicate by configuring CPM1-CIF01 adapter (supplied by OMRON) or by using communication modules C500-LK203, C120-LK201-V1 and C500-LK201-V1.

2.49.2 Parameters

HMI:

The default parameters of OMRON CP/CJ/CS series PLC: 9600, 7, 2, even parity, station no.0.

The default parameters of OMRON CPM/CQM series PLC: 9600, 7, 2, even parity, station no.0.

Parameter	Recommended settings	Choices of settings	Notes
PLC type	OMRON CPM/CQM series OMRON CP/CJ/CS series	OMRON CP/CJ/CS series OMRON CPM/CQM series	
Port	RS232	RS232/RS485	
Data bit	7	7 or 8	
Stop bit	2	1 or 2	
Parity	Even parity	Even/odd/ no parity	
Baud rate	9600	4800/38400/9600/115200 /19200/187500	
Station no.	0	0~255	

PLC:



Note:

- (1) The PLC startup mode in the startup item is set as monitor.
- (2) Set host link in the setting of serial port 1. Do not power off when changing this setting.
- (3) The default station number of OMRON is 0, not 1 when making the picture.
- (4) Select the DIP4 switch as off on the PLC body, so that the serial port 1 is in the setup state.

2.49.3 Cable making

(a) CPU RS232 port:

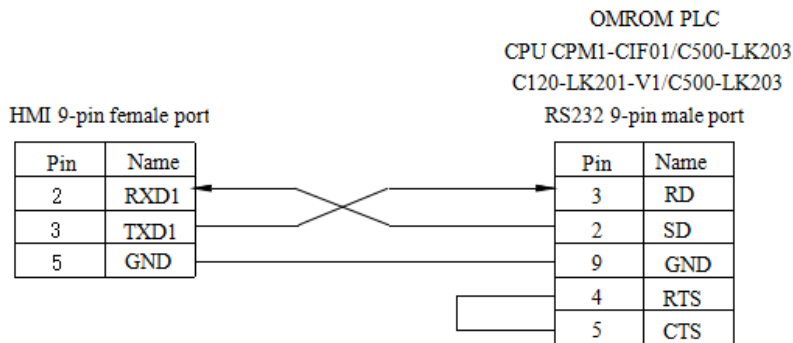

Fig1

(b) Through module CP1W-CIF11 RS485:

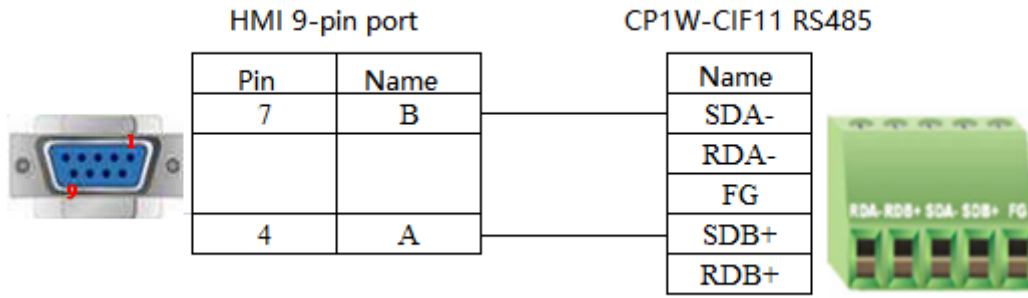

Fig2

Note: If OMRON PLC uses communication module CP1W-CIF11 RS485 for communication, turn OFF the SW1 switch on the module, turn ON SW2, 3, 5, 6 and SW4 is selectable.

(c) Through the module CP1W-CIF11 RS422:

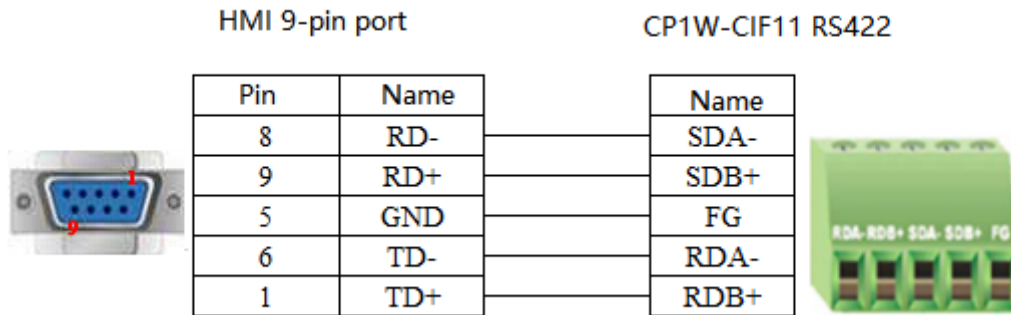

Fig3

Note: If OMRON module CP1W-CIF11 uses RS422 connection mode, turn OFF the SW1~6 on the module.

2.49.4 Device address

(a) SYSMAC CPM/CQM series

PLC address	Range	Data type	Explanation
IR	0~65535.15	Bit	I/O and internal relay
SR	244~65535.15	Bit	Relay
HR	0~65535.15	Bit	Holding relay
AR	0~65535.15	Bit	Auxiliary relay
LR	0~65535.15	Bit	Link relay
PV	0~65535.15	Bit	Current value of timer and counter
TC	0~65535	Bit	Timer and counter
IR	0~65535	Word/DWord	Register
SR	244~65535	Word/DWord	Register
HR	0~65535	Word/DWord	Register
AR	0~65535	Word/DWord	Register

LR	0~65535	Word/DWord	Register
PV	0~65535	Word/DWord	Register
TC	0~65535	Word/DWord	Register
DM	0~65535	Word/DWord	Data register (single/double words)

(b) SYSMAC CP/CJ/CS series

PLC address	Range	Data type	Explanation
CIO	0~9999.15	Bit	Input / output, CIO 100.00 as output
D	0~99999.15	Bit	Intermediate relay
H	0~9999.15	Bit	Power off hold relay
W	0~9999.15	Bit	Work area relay
A	0~9999.15	Bit	Auxiliary relay
T	0~9999	Bit	Timer
C	0~9999	Bit	Counter
CIO	0~9999	Word/DWord	Register
D	0~99999	Word/DWord	Register
H	0~9999	Word/DWord	Register
W	0~9999	Word/DWord	Register
A	0~9999	Word/DWord	Register
T	0~9999	Word/DWord	Register
C	0~9999	Word/DWord	Register

2.50 OMRON FinsTCP(Ethernet) CP series PLC

2.50.1 Device type

Series	CPU	Connected module	Port	Cable	PLC model in Touchwin software
CP 系列	CP1H	Communication module CP1W-CIF41	RJ45	Fig1 or Fig2	Omron(FinsTCP)series
	CP1L-E	Direct connect to CPU			

2.50.2 Parameters

Take CP1L-E series PLC as an example to illustrate the communication settings of Omron (FinsTCP) protocol .

PLC settings

Open the PLC software and configure the network module. The default IP address for communication is 192.168.250.1, and the default port number is 9600. This example sets default parameters for communication



Note: if the IP address is modified in the PLC, the "fins node number" should also be changed, otherwise the communication will fail.

HMI settings

(a) set the HMI model to TG (-ET) and click Next. In the Device list, select Net Device. In "Local IP Address", set the IP address of the HMI, as long as it does not conflict with other IP addresses on the network.

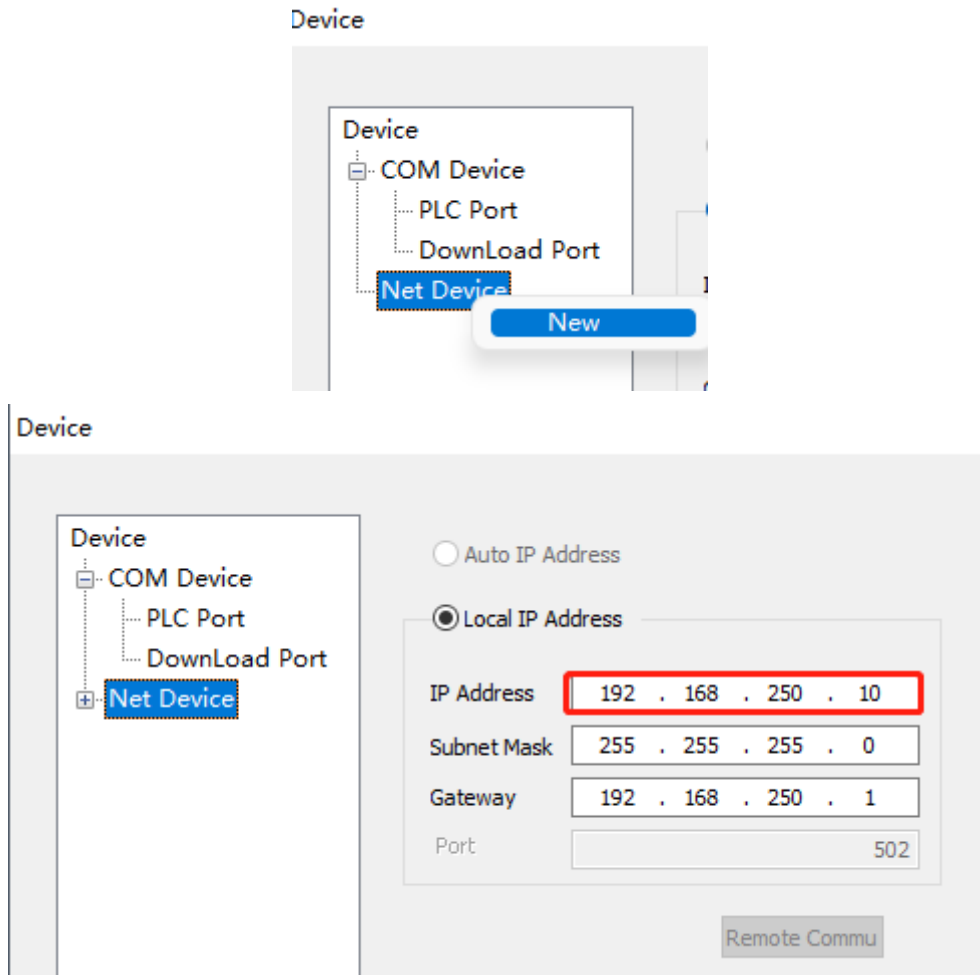

(b) Select "Omron(Fins TCP) Series" from the equipment list. This IP address is the IP address of Omron PLC, and the port number is the "Port number of this site" set in PLC software (decimal).

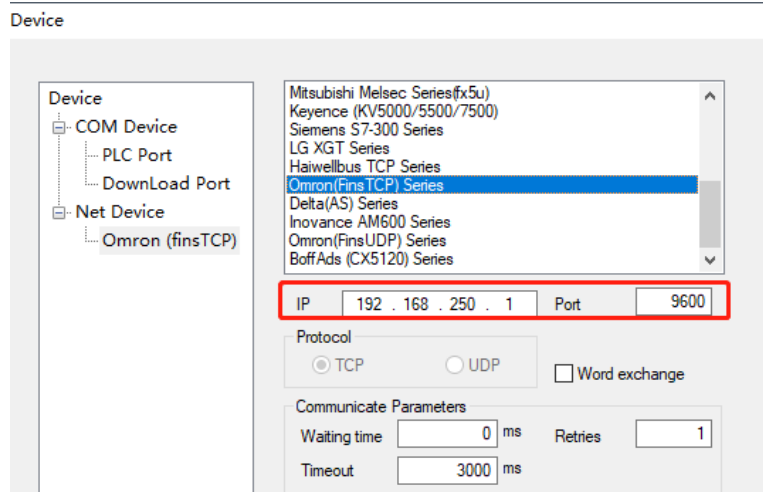

(c) Please keep the communication parameters as default, if the communicate status register is selected, PSW256~PSW259 respectively indicate communication successful times, failed times, overtime times, error times. User can set the register address as needs.

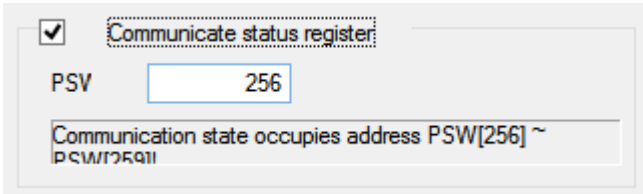

(d) Click next to finish the settings and enter screen edit interface. Put a data input button on the screen, and choose the Omron(fins TCP)in the device list.

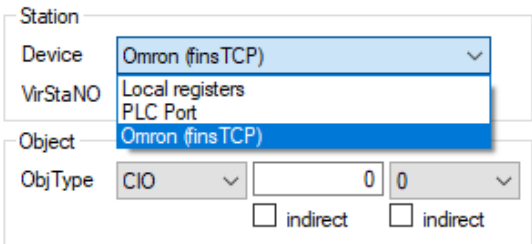

2.50.3 Cable making

RJ45 straight through cable (connect HUB) or RJ45 crossover cable:

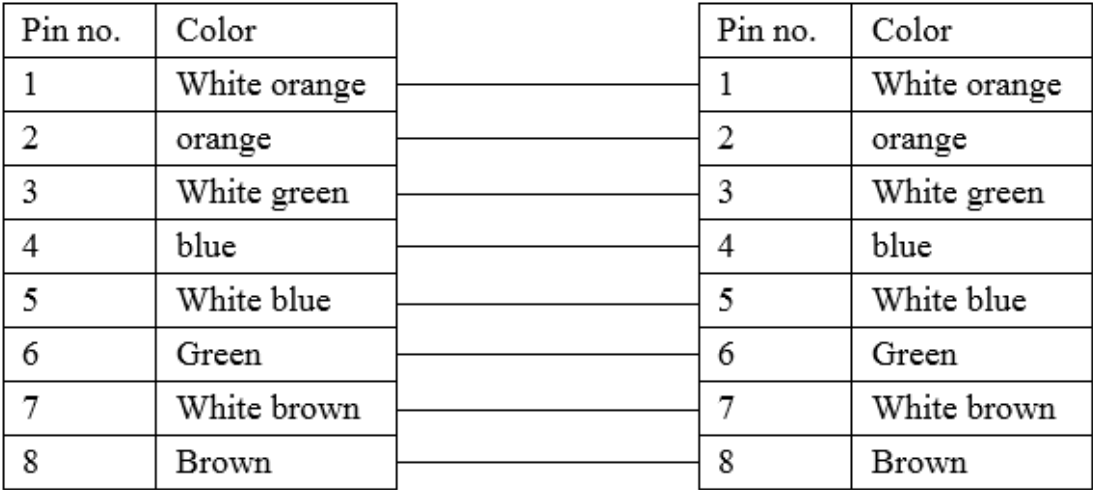

Fig 1

Pin no.	Color		Pin no.	Color
1	White orange	—————	1	White green
2	orange	—————	2	Green
3	White green	—————	3	White orange
4	blue	—————	4	blue
5	White blue	—————	5	White blue
6	Green	—————	6	orange
7	White brown	—————	7	White brown
8	Brown	—————	8	Brown

Fig 2

2.50.4 Device address

PLC address	Range	Data type	Explanation
CIO	0~9999.15	Bit	Input / output, CIO 100.00 as output
D	0~99999.15	Bit	Intermediate relay
H	0~9999.15	Bit	Power off hold relay
W	0~9999.15	Bit	Work area relay
A	0~9999.15	Bit	Auxiliary relay
T	0~9999	Bit	Timer
C	0~9999	Bit	Counter
CIO	0~9999	Word/DWord	Register
D	0~99999	Word/DWord	Register
H	0~9999	Word/DWord	Register
W	0~9999	Word/DWord	Register
A	0~9999	Word/DWord	Register
T	0~9999	Word/DWord	Register
C	0~9999	Word/DWord	Register

2.51 OPTO 22 SNAP series PLC

2.51.1 Device type

Series	CPU	Connected module	Port	Cable	PLC model in Touchwin software
OPTO 22	SNAP	Direct connect to CPU	RS232	Fig 1, fig 2	OPTO 22 series
			RS485	Fig 3	

2.51.2 Parameters

HMI:

Parameters	Recommend settings	Choices of settings	Note
PLC type	OPTO 22 series PLC		
Port	RS232	RS232/RS485	
Data bit	8	7 or 8	
Stop bit	1	1 or 2	
Parity	No parity	Even/odd/no parity	
Baud rate	115200	4800/38400/9600/115200/19200/187500	
Station no.	1	0~255	

The default parameters of OPTO 22 series PLC: 115200, 8, 1, no parity, station no.1

2.51.3 Cable making

(a) RS232 connection:

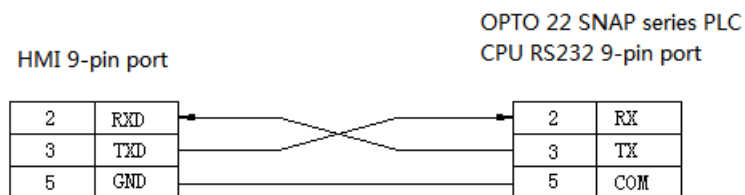

Fig1

(b) RS485 connection:

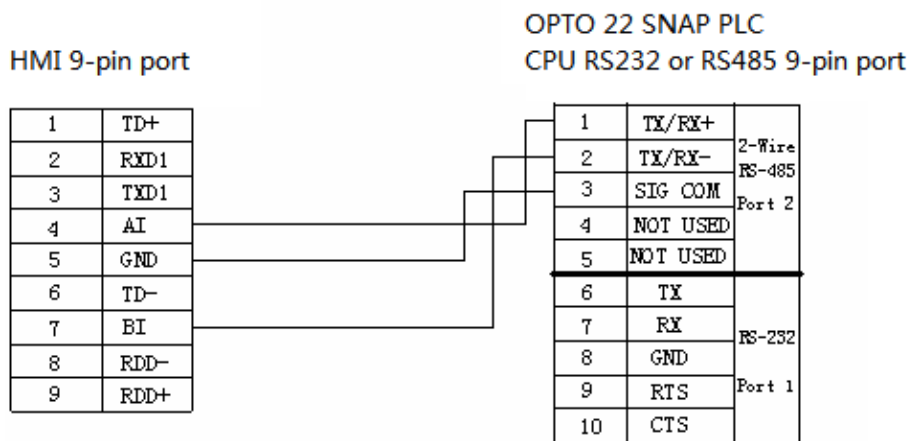

Fig2

(c) RS232 connection:

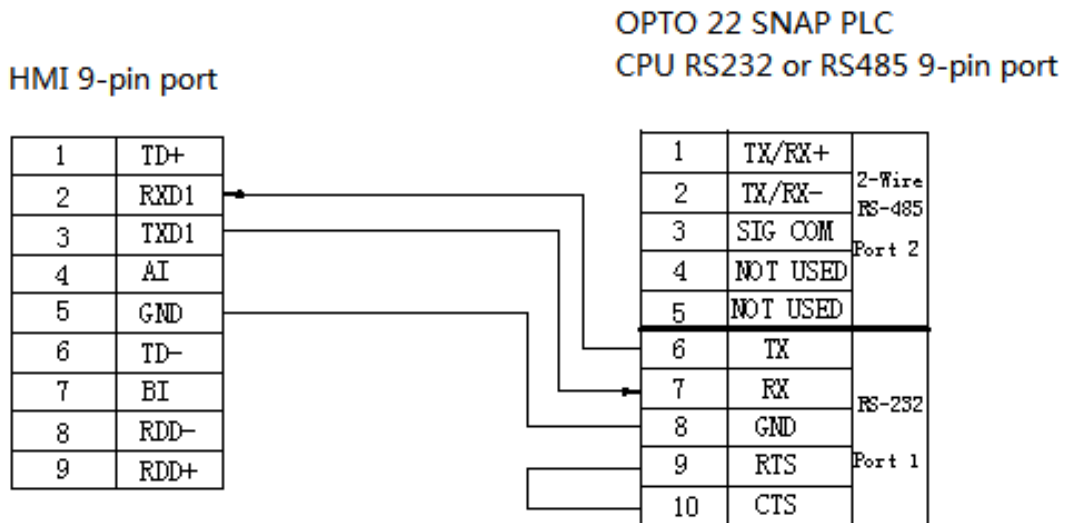

Fig3

2.51.4 Device address

PLC address	Range	Data type	Explanation
DI	0~9999	Bit	External input coil
DO	0~9999	Bit	External output coil
PID000~PID031	0~6	Bit	
I	0~9999	DWord	Used as register
F	0~9999	DWord	Used as register
AI	0~9999	DWord	Used as register
AO	0~9999	DWord	Used as register
PID000~PID031	0~5	DWord	PID parameters

2.52 Panasonic FP series PLC

2.52.1 Device type

Series	CPU	Connected module	Port	Cable	PLC model in Touchwin software
FP	FPΣ	Direct connect to CPU	RS232	Fig 1	Matsushita (FP0/FP1)
	FP0 FP0R-C32CT				
	FPG				
	FP-X				
	FP-M FP-E				
	FP2 FP2SH	Direct connect to CPU	RS232	Fig 1	
		CPU RS232 port	RS232	Fig 2	
	FP1	CPU RS232 port	RS232	Fig 2	
		CPU RS422 programming port	RS422	Fig 3	
	FP3	CPU RS422 programming port	RS422	Fig 4	
FP10SH FP10S	CPU RS232 port	RS232	Fig 2		

Note: FP-XH protocol is different from FP-X. If the PLC model is FP-XH, only Modbus RTU (Panel is Master) can be selected.

2.52.2 Parameters

HMI settings

Parameters	Recommend settings	Choices of settings	Note
PLC type	Matsushita (FP0/FP1)		
Port	RS232	RS232/RS422	
Data bit	8		
Stop bit	1		
Parity	Odd parity		
Baud rate	9600	9600/19200/38400/57600/115200	
Station no.	1	0~255	

PLC settings

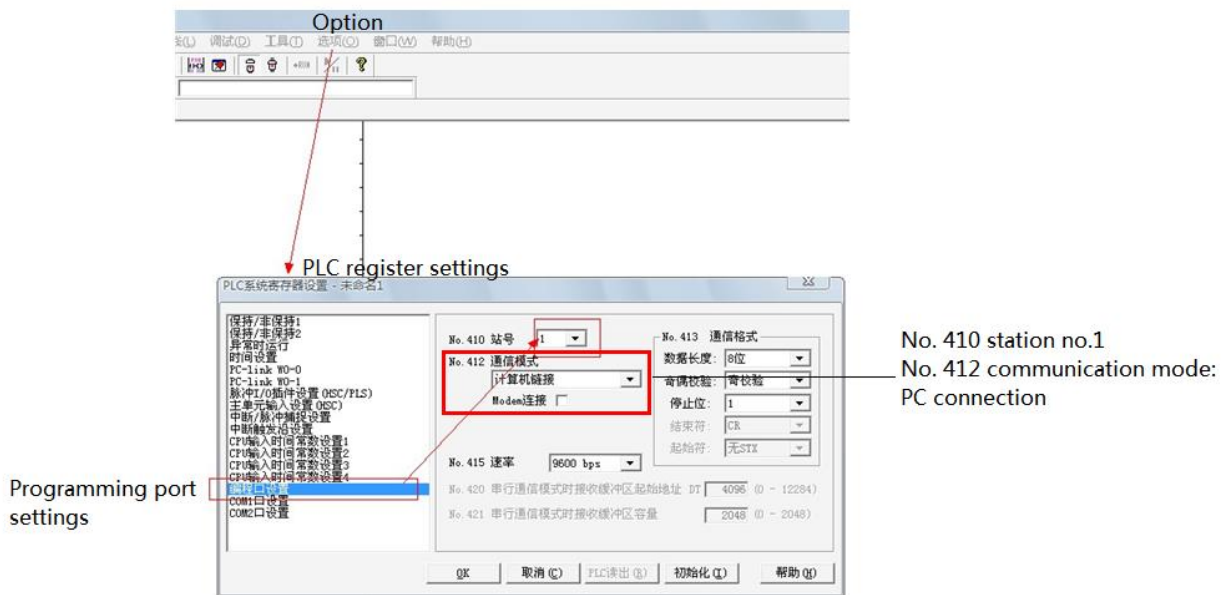

Note:

(1) PLC soft element input mode:

LC	screen
R45	R 4 5
Y1	Y 0 1

(2) When writing the PLC program, turn the dial switch to the PPOG status. During communication, the dial switch should be set to RUN status.

(3) Set the PLC station number and communication parameters, and do not select < general communication mode >, otherwise the communication will be abnormal.

(4) The default station number of FP series PLC is 1, but the FP3 model must be set to 0.

2.52.3 Cable making

(a) CPU 5-pin port:

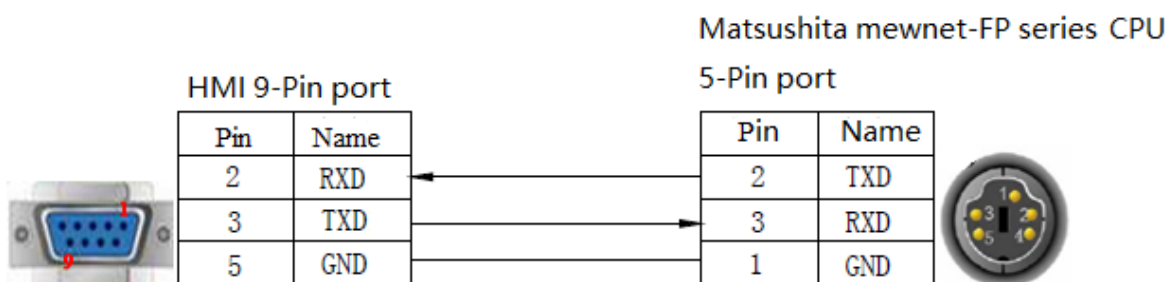

Fig 1

(b) CPU RS232 9-pin port

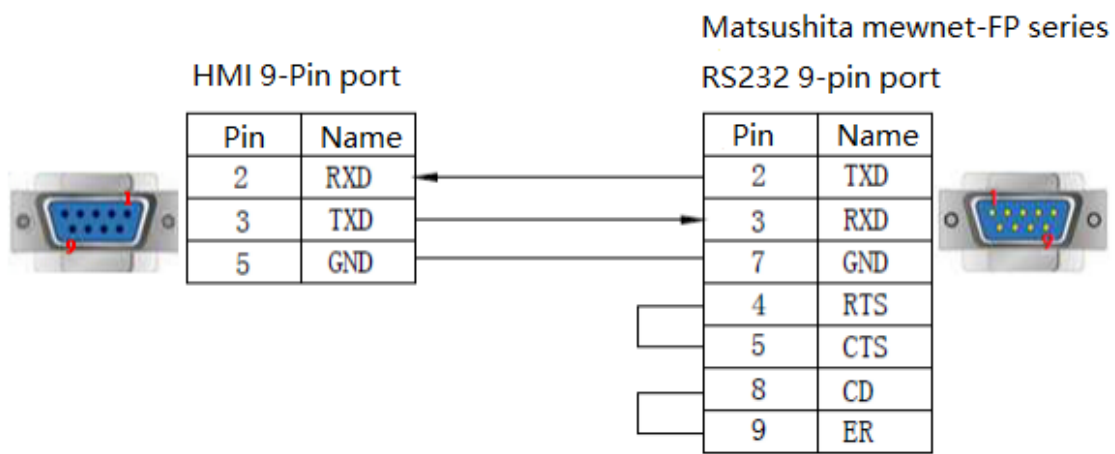

Fig 2

(c) CPU RS422 8-pin port

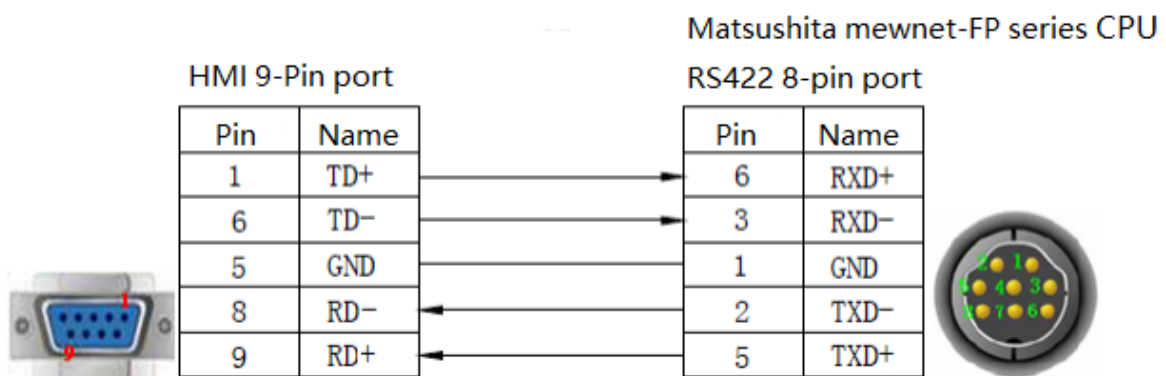

Fig 3

(d) CPU RS422 15-pin port:

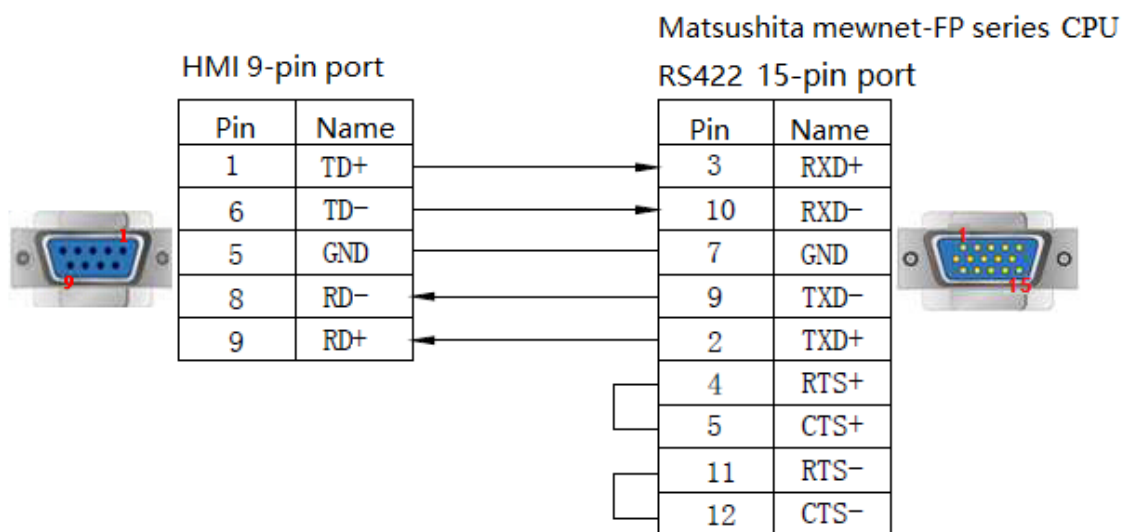

Fig 4

2.52.4 Device address

PLC address	Range	Data type	Explanation
X	0.0~12.F	Bit	Input (bit operation)
Y	0.0~12.F	Bit	Output (bit operation)
R	0.0~65535.F	Bit	Internal auxiliary relay (bit operation)
T	0~99	Bit	timer
L	0.0~65535.F	Bit	Connecting the control relay
C	100~143	Bit	Counter
WX	0~12	Word/DWord	Single word/double word register
WY	0~12	Word/DWord	Single word/double word register
WR	0~65535	Word/DWord	Single word/double word register
FL	0~65535	Word/DWord	Connection control register
SV	0~143	Word/DWord	Timer or counter set value register
EV	0~143	Word/DWord	Timer or counter actual value register
DT	0~65535	Word/DWord	Single word/double word data register

2.53 SAIA-Burgess PCD series PLC

2.53.1 Device type

SAIA—Burgess PCD series PLC communicates with Xinje HMI via socket A or socket B port.

(a) Direct connect to CPU

CPU	Connected module	Port	Cable	PLC model in Touchwin software
PCD1.M110 PCD1.M125 PCD1.M135	CPU PORT #0	RS232	Fig 1	SAIA—Burgess PCD series
PCD2.M120 PCD2.M150 PCD2.M170	CPU PORT #0	RS485	Fig 2	
PCD2.M480	CPU PORT #6			

(b) Through serial port

CPU	Connected module	Port	Cable	PLC model in Touchwin software
PCD1.M125 PCD1.M135 PCD1.M110 PCD1.M120 PCD2.M480 PCD2.M170 PCD2.M150 Socket A	PCD7.F110	RS485	Fig 4	SAIA—Burgess PCD series
		RS422	Fig 5	
	PCD7.F120	RS232	Fig 3	
PCD2.M170	PCD2.F520 PCD7.F772/F802	RS232	Fig 6	
		RS485	Fig 7	
		RS422	Fig 10	
PCD2.M170	PCD2.F520/F530 PCD7.F772/F802	RS232	Fig 6	
		RS485	Fig 7	
		RS485	Fig 8	
PCD2.M480	PCD2.F520/F522	RS232	Fig 9 or fig 11	
		RS422	Fig 10	

2.53.2 Parameters

HMI:

Parameters	Recommend settings	Choices of settings	Note
PLC type	SAIA—Burgess PCD Series PLC		
Port	RS232	RS232/RS485	
Data bit	8	7 or 8	
Stop bit	1	1 or 2	
Parity	No parity	Even/odd/no parity	
Baud rate	19200	4800/38400/9600/115200/19200/187500	
Station no.	0	0~255	

SAIA—Burgess PCD series PLC: 19200, 8, 1, no parity, station no.0

2.53.3 Cable making

(a) Direct connect to PGU RS232:

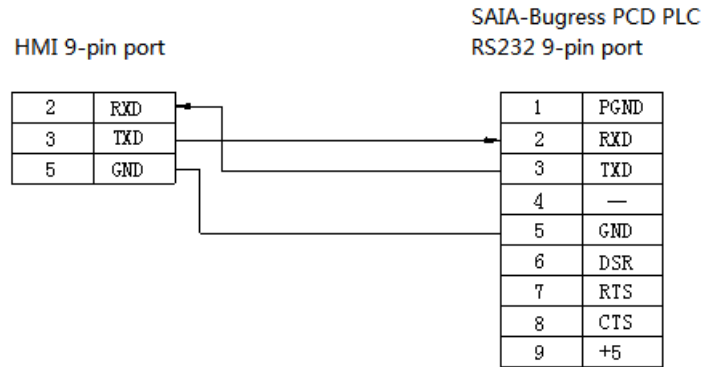

Fig1

(b) Direct PGU RS485:

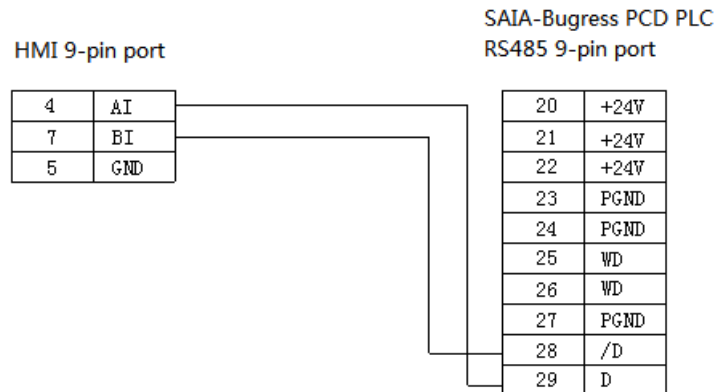

Fig2

(c) Socket A port (PCD7.F120):

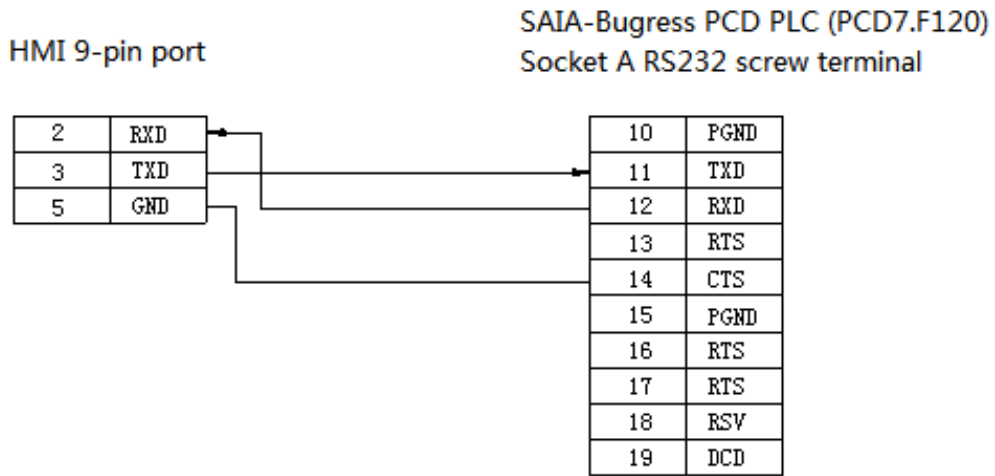

Fig3

(d) Through Socket A port (PCD7.F110):

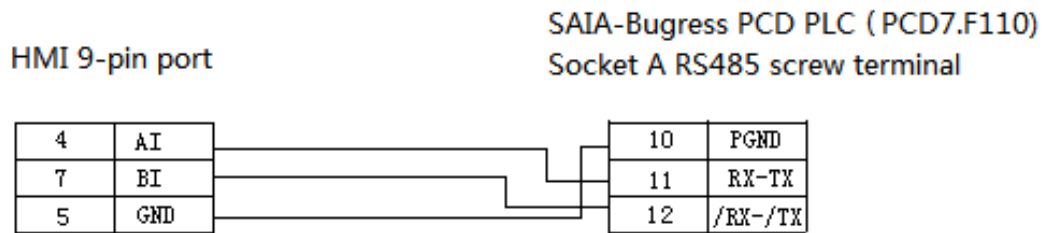

Fig4

(e) Socket A port (PCD7.F110):

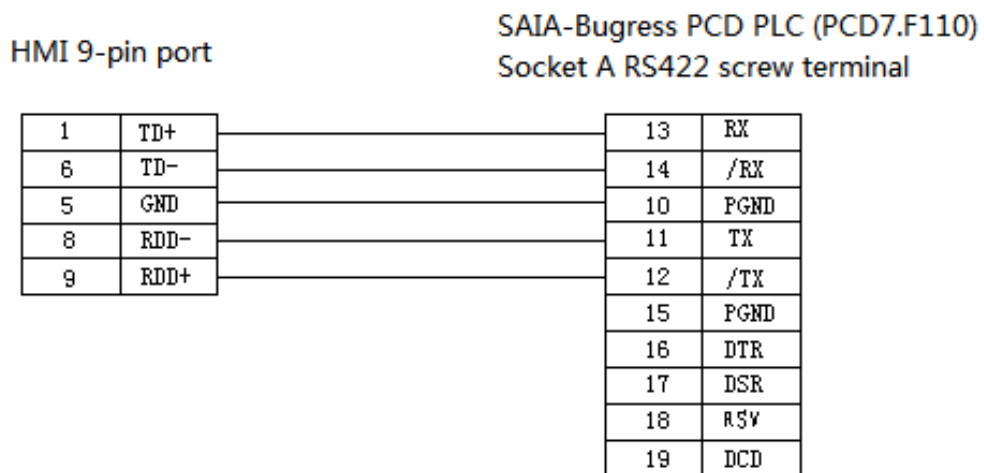

Fig5

(f) Socket B/B1 and B2 port (PCD2.F520/F530):

SAIA-Bugress PCD PLC (PCD2.F520/F530)
Socket B/B1 and B2 RS232 screw terminal

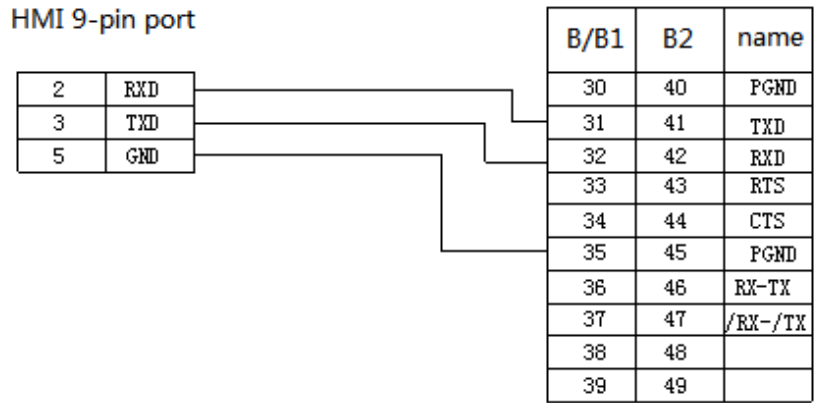

Fig6

(g) Socket B/B1 and B2 port (PCD2.F520/F530):

SAIA-Bugress PCD PLC (PCD2.F520/F530)
Socket B/B1 and B2 RS485 screw terminals

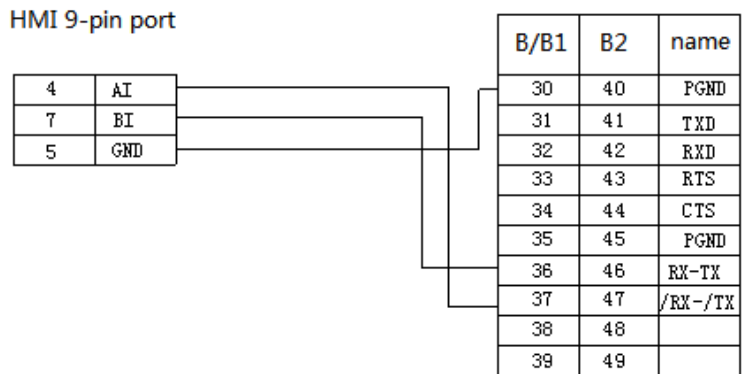

Fig7

(h) Socket B/B1&B2 port (PCD7.F772/F802):

SAIA-Bugress PCD PLC (PCD7.F772/F802)
Socket B/B1&B2 RS485 screw terminals

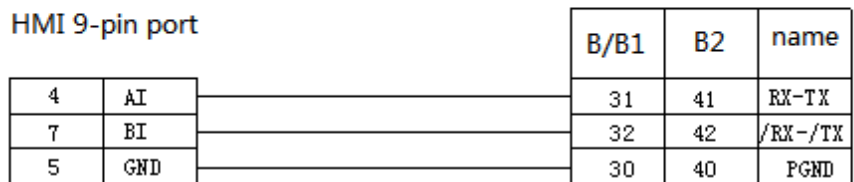

Fig8

(i) Socket B/B1&B2 port (PCD2.520/F530):

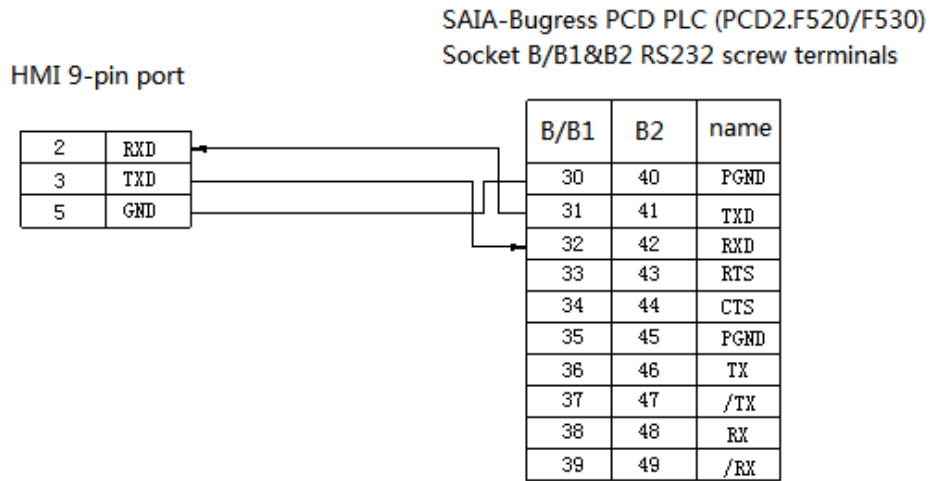

Fig9

(j) Socket B/B1&B2 port (PCD2.F520/F530):

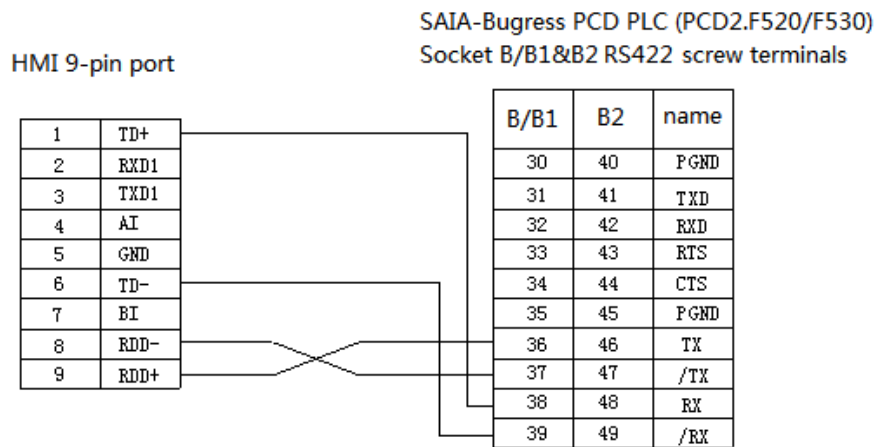

Fig10

(k) Socket B/B1&B2 port (PCD2.F520/F530):

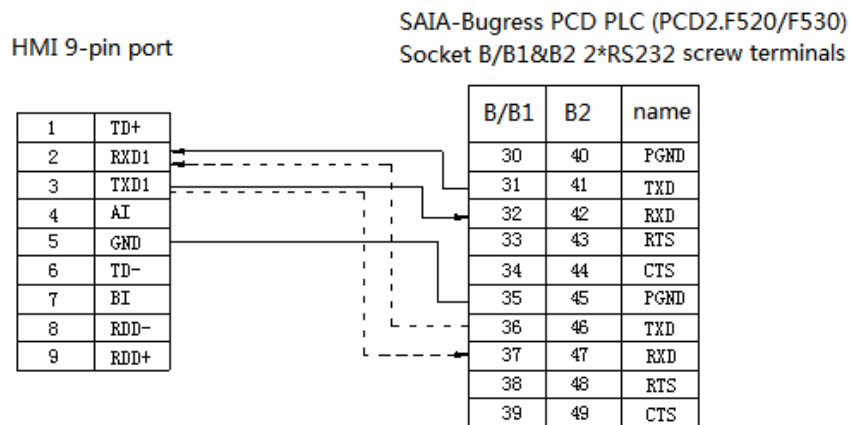

Fig11

2.53.4 Device address

PLC address	Range	Data type	Explanation
R	0~4095	DWord	Used as register
T	0~1599	DWord	Used as register
C	0~1599	DWord	Used as register
F	0~8000	Bit	Auxiliary coil
I	0~1023	Bit	External input coil
O	0~1023	Bit	External output coil

2.54 Sanken VM06 inverter

2.54.1 Device type

Series	Port type	Cable making	PLC model in Touchwin software
VM06	RS485	Fig 1	Sanken VM06 Inverter
			Modbus RTU (Panel is Master)

2.54.2 Parameters

Select Sanken VM06 inverter:

HMI:

Parameter	Recommended setting	Choices of setting	Note
PLC type	Sanken VM06 inverter	-	-
Port type	RS485	RS485	
Data bit	8	-	
Stop bit	1	-	
Parity	Even parity	-	
Baud rate	9600	9600/115200/19200/187500	
Station no.	1	0~31	

Select Modbus RTU (Panel is master)

HMI:

Parameter	Recommended setting	Choices of setting	Note
PLC type	Modbus Rtu (Panel is master)	-	-
Port type	RS485	RS485	
Data bit	8	-	
Stop bit	1	-	
Parity	Even parity	-	
Baud rate	9600	9600/115200/19200/187500	
Station no.	1	0~31	

Communication Parameter

Baudrate
 4800 56000
 9600 57600
 19200 115200
 38400 187500

Data Bit
 7Bits 8Bits

Stop Bit
 1Bit 2Bits

Parity check
 None Odd Even

Wait
 Communication Time MSEL

Send Data Vir Station Retry times

Exchange WORD

OK Cancel

Inverter:

Function	Name	Content	Debug parameters
F1002	Frequency setting	1: operate panel 2: external analog voltage VIF1 (0~5V) 21: terminal stepper 22: communication	22
F1101	Running command selection	1. Operate panel 2. External terminals 3. communication	3
F4002	RS232C/RS485	1: RS232C (default setting) 2: RS485	Choose according to wiring method
F4005	Serial communication function	0: no function (default setting) 1: special protocol communication 2: Modbus communication	2
F4006	Inverter station no.	0~254: ModBus station no. (1~32: RS485 communication) 1~32 is valid in special protocol communication	1
F4007	Baud rate	1: 1200bps 2: 2400bps 3: 4800bps 4: 9600bps 5: 19200bps 6: 38400bps 7: 57600bps	4
F4008	Parity	0: no 1: odd (default setting) 2: even	2
F4009	Stop bit	1: 1 bit (default setting) 2: 2 bit	1
F4010	Stop code	0: CR+LF (default setting)	0

		1: CR ※BINARY and Modbus without stop code	
--	--	---	--

2.54.3 Cable making

RS485:

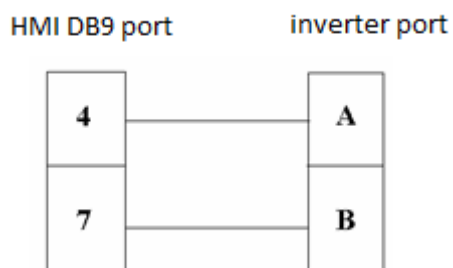

Fig 1

2.54.4 Device address

Inverter Modbus address

Function code	Upper limit frequency	33775	Data input/display
	Setting frequency	34869	Function button-set data
Register	Forward running	1001	Function button (2)
	Reverse running	1001	Function button (8)
	Setting frequency	1000	Function button

2.55 Schneider PLC

2.55.1 Device type

Series	CPU	Connected module	Port	Cable	PLC model in Touchwin software
Micro	TSX 37-05 TSX 37-08 TSX 37-10 TSX 37-21/22	Direct connect to CPU	RS485	Fig 1	Schneider Micro/ Neza/Twido Series PLC
Twido	Twido series CPU	Direct connect to CPU	RS485	Fig 1	
M	M218 M238 M258	Direct connect to CPU	RS485	Fig 2	
NEZA	TSX07 series CPU	Direct connect to CPU	RS485	Fig 1	

2.55.2 Parameters

HMI:

Parameters	Recommend settings	Choices of settings	Note
PLC type	Schneider Micro/Neza /Twido series PLC		
Port	RS485		
Data bit	8	7 or 8	
Stop bit	1	1 or 2	
Parity	No parity	Even/odd/no parity	
Baud rate	19200	4800/38400/9600/115200/19200/187500	
Station no.	1	0~255	

The default parameters of Schneider Micro/NEZA/ Twido series PLC: 19200, 8, 1, even parity, station no.1

Communicate parameters ×

Baud Rate
 4800 56000
 9600 57600
 19200 115200
 38400 187500

Data bit
 7位 8位

Stop bit
 1位 2位

Checksum
 No parity Odd Even

Delay
 Send delay time ms

Send data Virtual Station
 Word exchange Retry Tim

PLC:

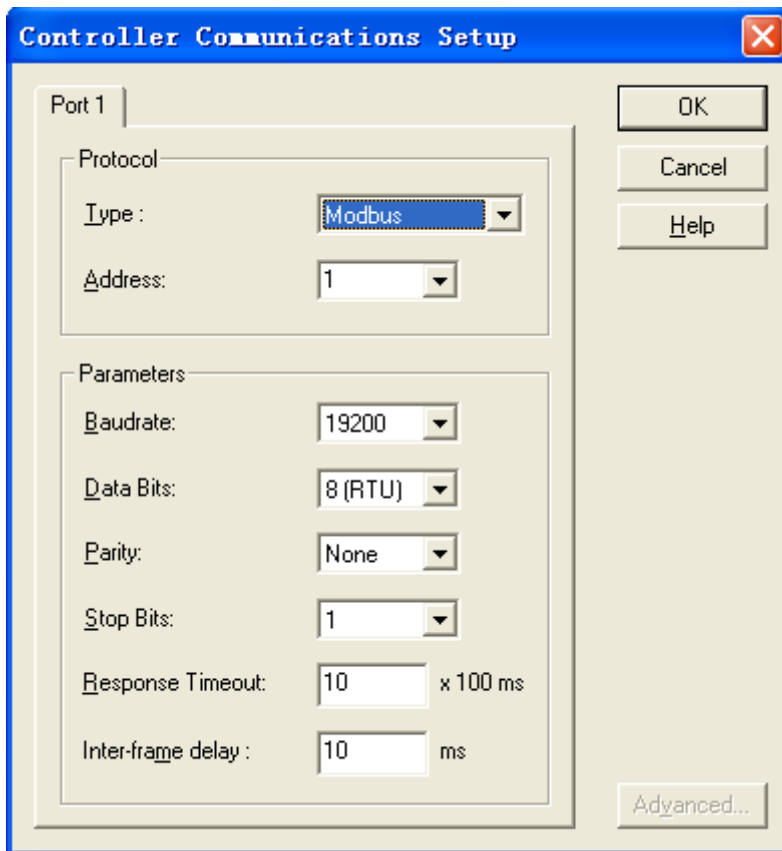
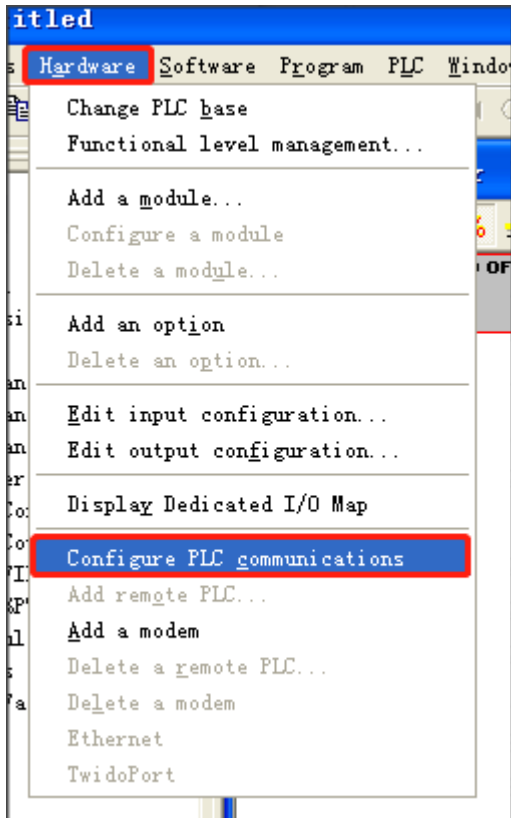

Note:

The object address of Twido PLC is dynamic and can be enlarged in the PLC programming software. Please release the max coil address in the program. For example: the max coil address is M127, please output M127 in the program.

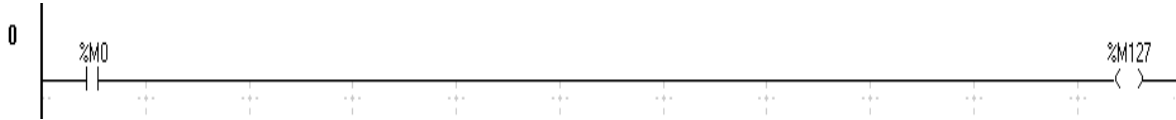

2.55.3 Cable making

(a) Direct connect to CPU:

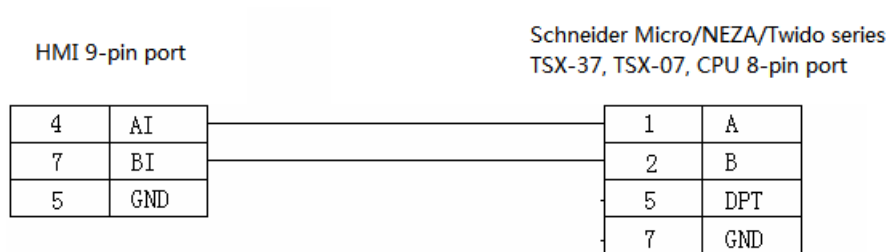

Fig1

(b) M238 RJ-45 RS485:

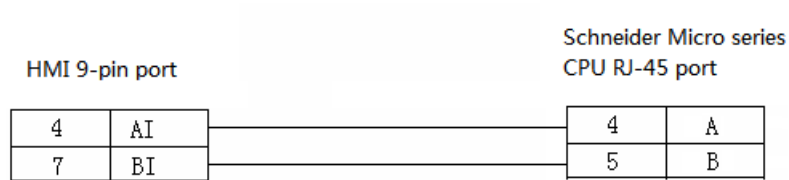

Fig2

2.55.4 Device address

PLC address	Range	Data type	Explanation
M	0~2047	Bit	Internal coil
MW	0.00~65535.15	Bit	Internal coil
MW	0~2047	Word/DWord	Register

2.56 SHIMADEN

2.56.1 Device type

Series	Connected module	Port	Cable	PLC model in Touchwin software
SRS10(SRS11/SRS13/SRS14) Digital adjustor	RS485 on the CPU unit	RS485	Fig 1	Modbus RTU (Panel is Master)

Note: all the devices support Modbus protocol can communicate with Touchwin HMI.

2.56.2 Parameters

HMI:

Parameters	Recommend settings	Choices of settings	Note
PLC type	Modbus RTU (Panel is Master)		
Port	RS485	RS485	
Data bit	8	7 or 8	
Stop bit	1	1 or 2	
Parity	Even parity	Even/odd/no parity	
Baud rate	9600	4800/38400/9600/115200/19200/187500	
Station no.	1	0~255	

Note:

1. The parameters of device and HMI must be same.
2. Some devices need to add terminal resistor (such as SRS10 digital adjustor)
3. Meter parameter 018C must set to 1 (COM LED is ON), please use the “function filed”(the button in the Touchwin software) to set the value of 018C(4x396=1).

2.56.3 Cable making

RS485 connection:

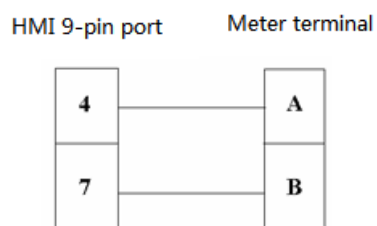

Fig1

2.56.4 Device address

PLC address (Hex)	Parameters	Read/write	Meaning
0100	PV	Read	Measured value
0101	SV	Read	Setting value
0102	OUT1	Read	Output 1
0103	OUT2	Read	Output 2
0104	EXE_FLG	Read	Status sign
0105	EV_FLG	Read	event output sign
0300	FIX SV1	Read/write	Fixed value 1
0301	FIX SV2	Read/write	Fixed value 2
0302	FIX SV3	Read/write	Fixed value 3
030A	SV_L	Read/write	Lower limit of settings
030B	SV_H	Read/write	Upper limit of settings

2.57 Siemens S7-200 series PLC

2.57.1 Device type

Series	CPU	Connected module	Port	Cable	PLC model in Touchwin software
S7-200	CPU212 CPU221 CPU222 CPU224 CPU226	Connect CPU RS485 port directly	RS485	Fig 1	Siemens S7-200
S7-200 smart	Smart series				

2.57.2 Parameters

HMI:

Parameters	Recommend settings	Choices of settings	Item
PLC type	S7-200		
Port	RS485		
Data bit	8		
Stop	1		
Parity	Even parity		
Baud rate	9600	9600/19200/187500	
Station no.	2		

The default communication parameters of Siemens S7-200 series PLC: 9600, 8, even parity, station No.2.

PLC settings:



Notes:

1. Siemens PLC has 3 kinds of registers: 8-bit VB, 16-bit VW and 32-bit VD.
2. The space of registers are overlapped, the address of VW must be even numbers, for example: VW0, VW2, ..., the address of VD must be the multiple of 4, such as VD0, VD4, VD8,
3. For Data block PSW single word → VW single word: as the high byte and low byte problem, the received data maybe dislocated, please use register copy function.
4. For data block PSW single word → VD double words: as the unit is different, cannot transfer the data like this, please use register copy function.

2.57.3 Cable making

HMI connects to S7-200 via RS485:

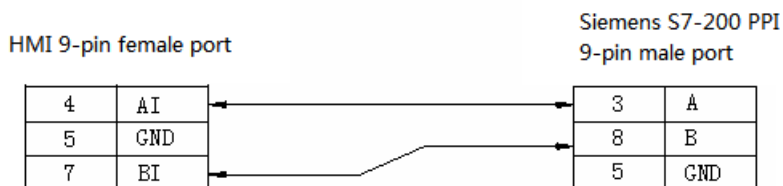

Fig1

2.57.4 Device address

SIMATIC S7-200 series

PLC address	Range	Data type	Explanation
VB	0~4095	Byte	variable byte data register
VW	0~4095	Word	variable word data register
VD	0~4095	DWord	variable double word data register
IB	0~15	Byte	External input byte reflection register
IW	0~15	Word	External input word reflection register
ID	0~15	DWord	External input double words reflection register
QB	0~15	Byte	External output byte reflection register
QW	0~15	Word	External output word reflection register
QD	0~15	DWord	External output double words reflection register
MB	0~31	Byte	Internal auxiliary byte register
MW	0~31	Word	Internal auxiliary word register
MD	0~31	DWord	Internal auxiliary double words register
SMB	0~299	Byte	Internal special auxiliary byte register
SMW	0~299	Word	Internal special auxiliary word register
SMD	0~299	DWord	Internal special auxiliary double words register
SB	0~31	Byte	Special auxiliary byte register
SW	0~31	Word	Special auxiliary word register
SD	0~31	DWord	Special auxiliary double words register
T	0~255	Word	Register
C	0~255	Word	Register
M	0~31	Bit	Bit register
V	0~4095	Bit	Variable register
I	0~15	Bit	External input coil
Q	0~15	Bit	External output coil
SM	0~299	Bit	Special relay
S	0~31	Bit	Sequence relay
T	0~255	Bit	Timer
C	0~255	Bit	Counter

2.58 Siemens S7-300/400 series PLC

2.58.1 Device type

SIMATIC S7-300/400 PLC (connect to CPU directly)

Series	CPU	Connected module	Port	Cable	PLC model in Touchwin software
S7-300	CPU312 CPU314 CPU315	RS485 port of CPU	RS485	Fig1	Siemens SIMATIC S7-300/400 PLC
S7-400	CPU412-1 CPU412-2 CPU414-2				

2.58.2 Parameters

HMI settings:

Parameter	Recommend settings	Choice of settings	Note
PLC type	S7-300/400		
Port	RS485		
Data bit	8	7 or 8	
Stop bit	1	1 or 2	
Parity	Even parity	Even/odd/no parity	
Baud rate	19200	4800/38400/9600/115200/19200/187500	
Station no.	2		Please use recommend settings

The default parameters of Siemens S7-300/400: 19200, 8, even parity, station No.2.

The image shows two overlapping dialog boxes from the Siemens SIMATIC Manager software. The left dialog, titled 'PLC Port', contains a list of PLC models with 'Siemens S7-300/400' selected. Below the list, the 'Parameters' field displays '19200, 8, Even, 1'. The 'Station' field at the bottom is highlighted with a red rectangular box and contains the value '0'. The right dialog, titled 'Communicate parameters', shows configuration options for the connection. Under 'Baud Rate', '19200' is selected. Under 'Data bit', '8位' is selected. Under 'Stop bit', '1位' is selected. Under 'Checksum', 'Even' is selected. The 'Send delay time' is set to 0 ms. At the bottom, there are 'OK' and 'Cancel' buttons.

PLC settings:

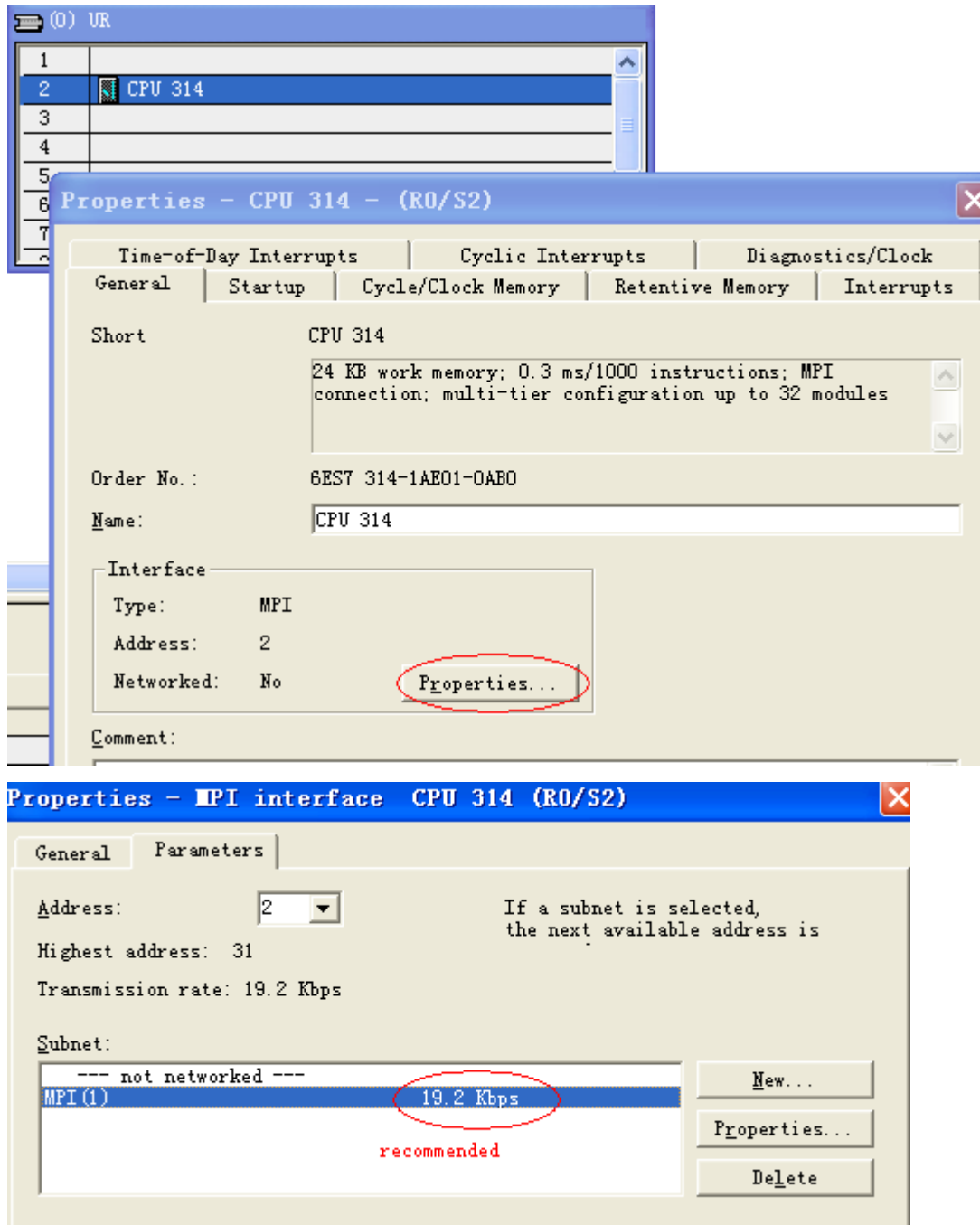

Communication notes for S7-300:

1. Siemens baud rate must set to 19200 kbps. Don't set the parameters of PG/PC adapter.
2. Don't modify the "station no.:0" in the Touchwin software.
3. Cable: no need PG/PC adapter.
4. Please define the DB register in the PLC when testing the communication.
5. Please note that the port will be operated in PLC program by accident.
6. The default station No. of S7-300 is 2, please don't modify it.

Example: MPI port of S7-300 connects to HMI, the PLC connects to SCADA software via Ethernet module, PLC station no. is 8, module station no. is 3, HMI station no. is 0. The result is

that communication between SCADA and PLC will be cut off. Because the HMI cannot find other devices and modules cannot be inserted in. please change the PLC station no. to 2. These devices can form a loop:

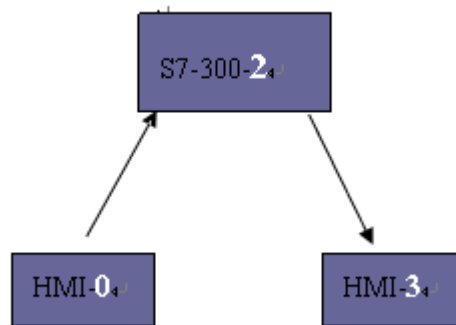

2.58.3 Cable making

HMI connects to S7-300/400 via RS485:

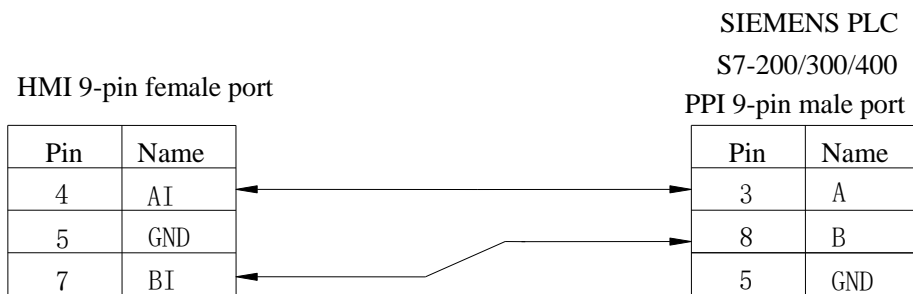

Fig1

2.58.4 Device address

SIMATIC S7-300/400

PLC type	Range	Data type	Explanation
I	0~9999	Byte/Word/DWord	External input register
Q	0~9999	Byte/Word/DWord	External output register
M	0~9999	Byte/Word/DWord	Internal auxiliary register
DB0~DB20	0~9999	Byte/Word/DWord	Data register
I	0~9999	Bit	External input coil
Q	0~9999	Bit	External output coil
M	0~9999	Bit	Internal auxiliary relay
DB0~DB20	0~9999	Bit	Internal auxiliary relay

2.59 Simens S7-200 smart (Ethernet) series PLC

2.59.1 Device type

Series	Port	Cable	PLC model in Touchwin software
S7-200 smart	RJ45	Fig 1or fig 2	Simens S7-200 Smart Series/Simens S7-200 Smart new Series(It is recommended to select this protocol when creating a new program)

2.59.2 Parameters

PLC settings

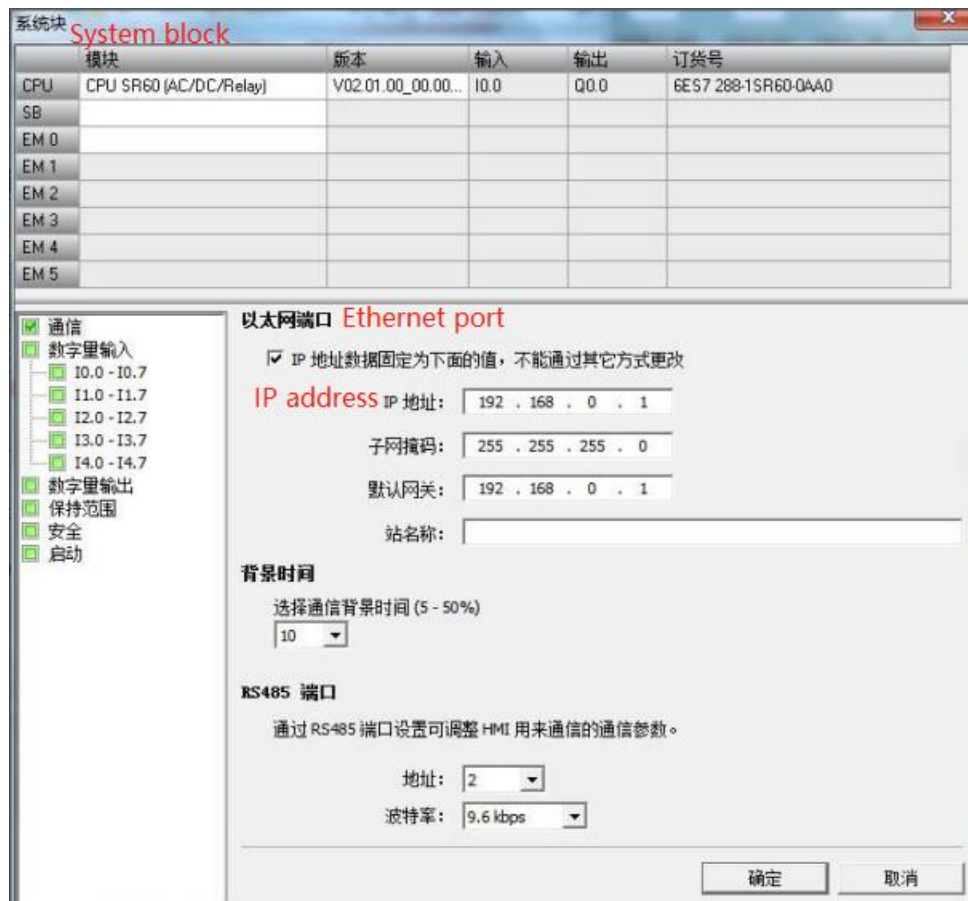

HMI settings

1. Choose the HMI type TN(-ET), TG(-ET) or TE(-ET), click next, choose Net device in the list, please input the HMI IP address in the own devices.

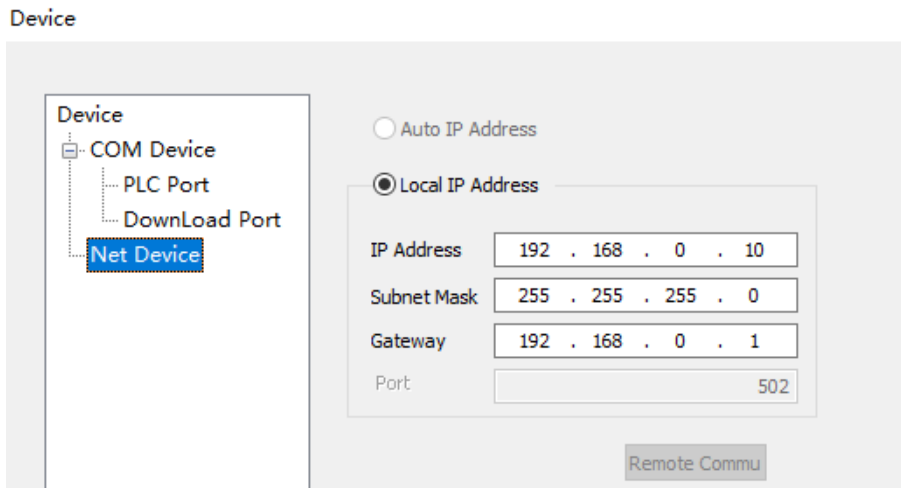

2. Choose the net device, right click it, choose new, and name it as S7-200 smart.

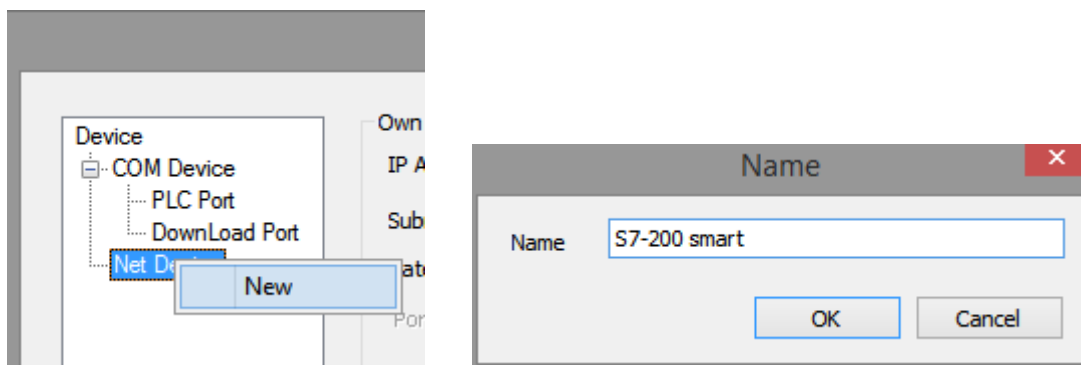

3. Choose Siemens S7-200 smart series in the device list, in this example, the PLC IP address is 192.168.0.1, the port is 102 which cannot be changed.

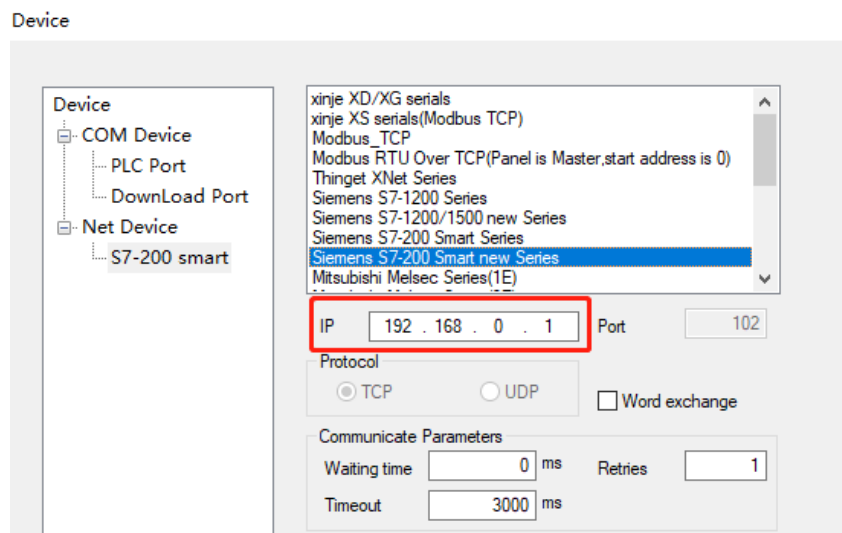

4. The communication parameters please use default settings. If communication status register is chosen, and set to PSW256, then PSW256~PSW259 means communication succeeded times, failed times, overtime times, error times. The register address can be set by user.

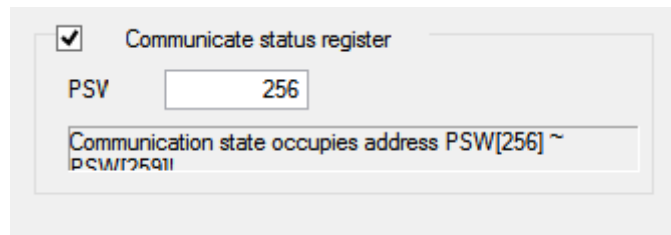

5. Click next to finish the settings. Then enter the screen, for example, put a data input button in the screen, choose the device S7-200 smart.

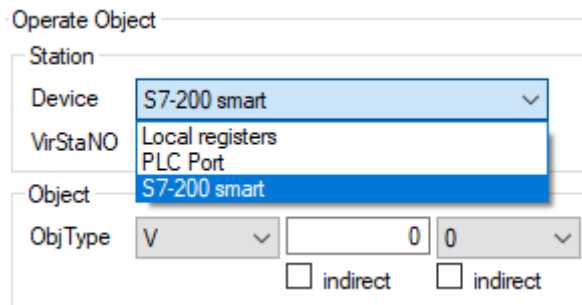

There is no station no. for Siemens S7-200 smart, set the correct IP address is ok. It can make the networks of multi-HMI-one-PLC, one-HMI-multi-PLC, multi-HMI-multi-PLC.

2.59.3 Cable making

RJ45 Straight Through Cable (connect HUB) or RJ45 Crossover Cable:

Pin no.	Color		Pin no.	Color
1	White orange	—————	1	White orange
2	orange	—————	2	orange
3	White green	—————	3	White green
4	blue	—————	4	blue
5	White blue	—————	5	White blue
6	Green	—————	6	Green
7	White brown	—————	7	White brown
8	Brown	—————	8	Brown

Fig 1

Pin no.	Color		Pin no.	Color
1	White orange	—————	1	White green
2	orange	—————	2	Green
3	White green	—————	3	White orange
4	blue	—————	4	blue
5	White blue	—————	5	White blue
6	Green	—————	6	orange
7	White brown	—————	7	White brown
8	Brown	—————	8	Brown

Fig 2

2.59.4 Device address

PLC address	Range	Data type	Explanation
VB	0~9999	Byte	variable byte data register
VW	0~9999	Word	variable word data register
VD	0~9999	DWord	variable double word data register
IB	0~15	Byte	External input byte reflection register
IW	0~15	Word	External input word reflection register
ID	0~15	DWord	External input double words reflection register
QB	0~15	Byte	External output byte reflection register
QW	0~15	Word	External output word reflection register
QD	0~15	DWord	External output double words reflection register
MB	0~31	Byte	Internal auxiliary byte register
MW	0~31	Word	Internal auxiliary word register
MD	0~31	DWord	Internal auxiliary double words register
SMB	0~299	Byte	Internal special auxiliary byte register
SMW	0~299	Word	Internal special auxiliary word register
SMD	0~299	DWord	Internal special auxiliary double words register
SB	0~31	Byte	Special auxiliary byte register
SW	0~31	Word	Special auxiliary word register
SD	0~31	DWord	Special auxiliary double words register
T	0~255	Word	Register
C	0~255	Word	Register
M	0.0~31.7	Bit	Bit register
V	0.0~9999.7	Bit	Variable register

I	0.0~15.7	Bit	External input coil
Q	0.0~15.7	Bit	External output coil
SM	0.0~299.7	Bit	Special relay
S	0.0~31.7	Bit	Sequence relay
T	0~255	Bit	Timer
C	0~255	Bit	Counter

2.60 Siemens S7-300 (Ethernet) series PLC

2.60.1 Device type

Series	Port	Cable	PLC model in touchwin software
S7-300	RJ45	Fig 1 or fig 2	Siemens S7-300 series

2.60.2 Parameter setting

PLC setting

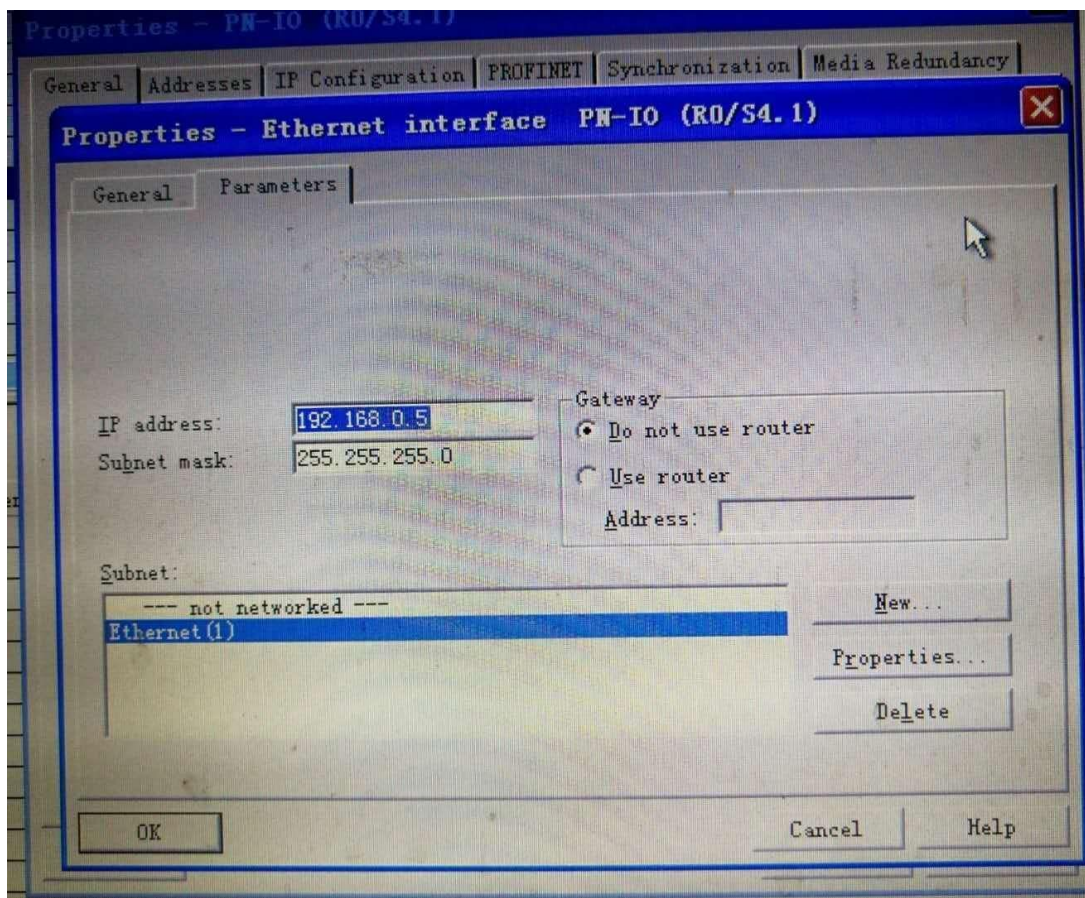

HMI setting

1. Choose the HMI type TN(-ET), TG(-ET) or TE(-ET), click next, choose Net device in the list, please input the HMI IP address in the own devices.

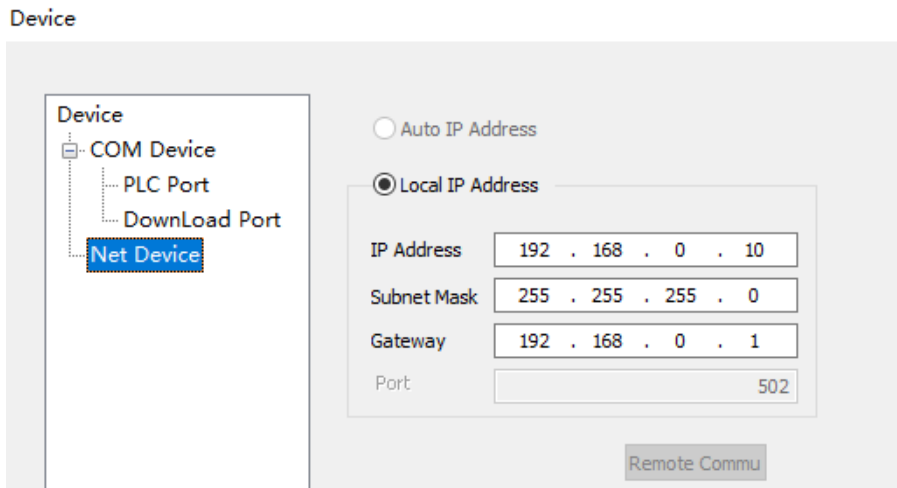

2. Choose the net device, right click it, choose new, and name it as Siemens S7-300.

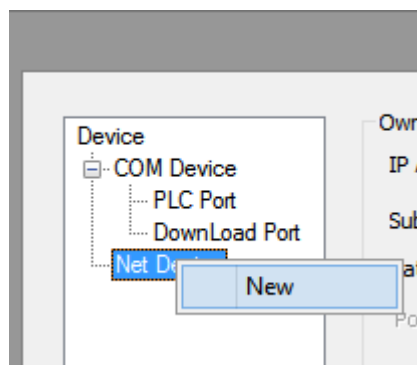

3. Choose Siemens S7-300 series in the device list, in this example, the PLC IP address is 192.168.0.5, the port is 102 which cannot be changed.

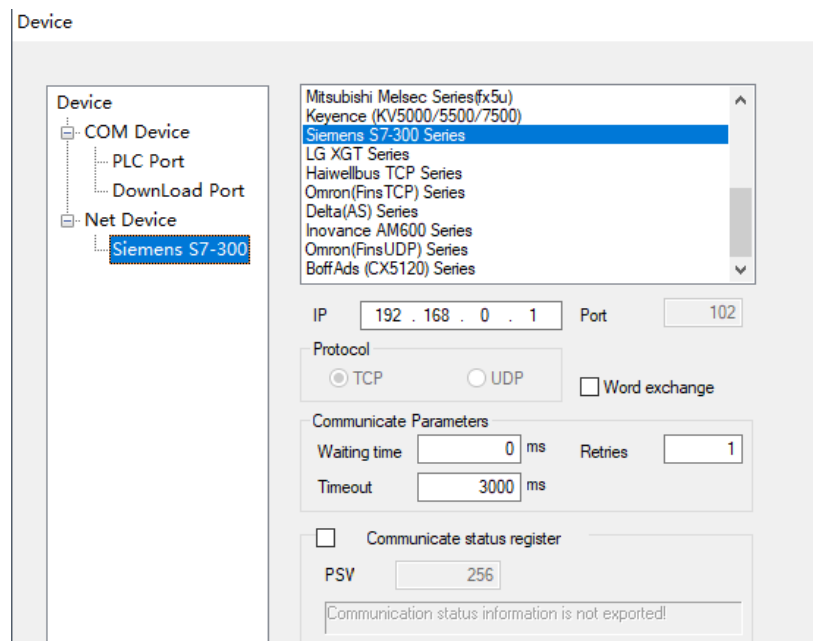

4. The communication parameters please use default settings. If communication status register is chosen, and set to PSW256, then PSW256~PSW259 means communication succeeded times, failed times, overtime times, error times. The register address can be set by user.

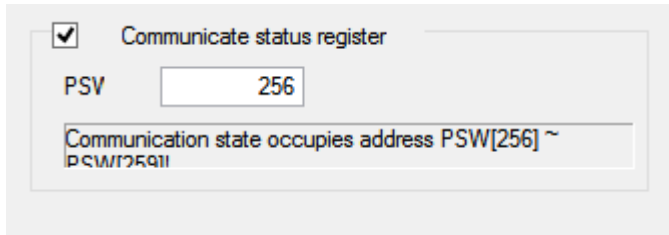

5. Click next to finish the settings. Then enter the screen, for example, put a data input button in the screen, choose the device S7-300.

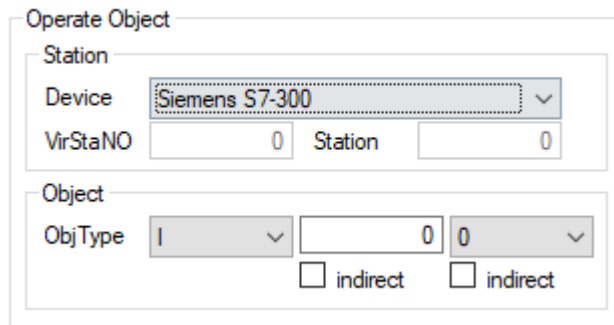

There is no station no. for Siemens S7-300, set the correct IP address is ok. It can make the networks of multi-HMI-one-PLC, one-HMI-multi-PLC, multi-HMI-multi-PLC.

2.60.3 Cable making

RJ45 Straight Through Cable (connect HUB) or RJ45 Crossover Cable:

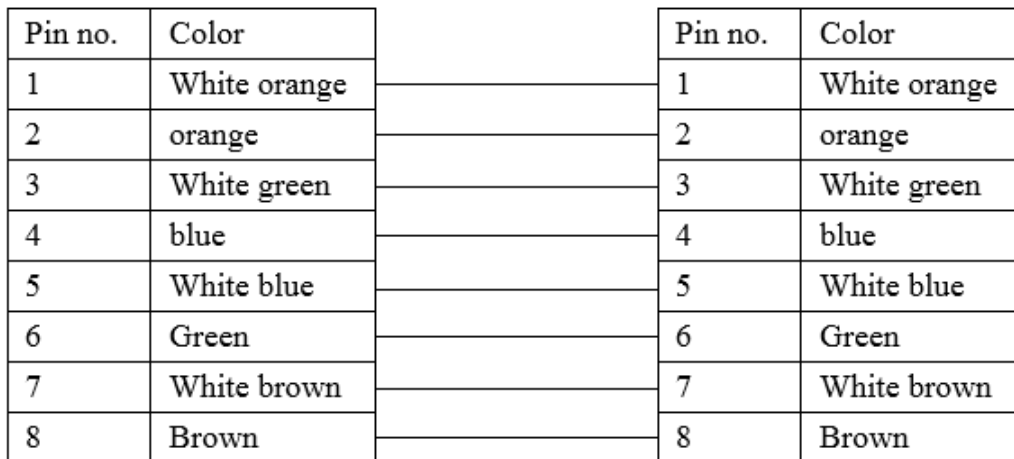

Fig 1

Pin no.	Color		Pin no.	Color
1	White orange		1	White green
2	orange		2	Green
3	White green		3	White orange
4	blue		4	blue
5	White blue		5	White blue
6	Green		6	orange
7	White brown		7	White brown
8	Brown		8	Brown

Fig 2

2.60.4 Device address

Siemens S7-300 series

PLC address	Range	Data type	Explanation
VB	0~9999	Byte	variable byte data register
VW	0~9999	Word	variable word data register
VD	0~9999	DWord	variable double word data register
IB	0~15	Byte	External input byte reflection register
IW	0~15	Word	External input word reflection register
ID	0~15	DWord	External input double words reflection register
QB	0~15	Byte	External output byte reflection register
QW	0~15	Word	External output word reflection register
QD	0~15	DWord	External output double words reflection register
MB	0~31	Byte	Internal auxiliary byte register
MW	0~31	Word	Internal auxiliary word register
MD	0~31	DWord	Internal auxiliary double words register
SMB	0~299	Byte	Internal special auxiliary byte register
SMW	0~299	Word	Internal special auxiliary word register
SMD	0~299	DWord	Internal special auxiliary double words register
SB	0~31	Byte	Special auxiliary byte register
SW	0~31	Word	Special auxiliary word register
SD	0~31	DWord	Special auxiliary double words register
T	0~255	Word	Register
C	0~255	Word	Register
M	0.0~31.7	Bit	Bit register
V	0.0~9999.7	Bit	Variable register

I	0.0~15.7	Bit	External input coil
Q	0.0~15.7	Bit	External output coil
SM	0.0~299.7	Bit	Special relay
S	0.0~31.7	Bit	Sequence relay
T	0~255	Bit	Timer
C	0~255	Bit	Counter

2.61 Siemens S7-1200 (Ethernet) series PLC

2.61.1 Device type

Series	Communication type	Cable making	PLC model in Touchwin software
S7-1200	RJ45	Fig 1 or 2	Siemens S7-1200/1500 new series
S7-1500			

2.61.2 Parameters

PLC software settings:

Take Siemens S7-1200 CPU1211C 6ES7 211-1BD30-0XB0 PLC as an example to explain the settings

(a) Open project-devices&networks-normal-Ethernet IP, set the PLC IP address:

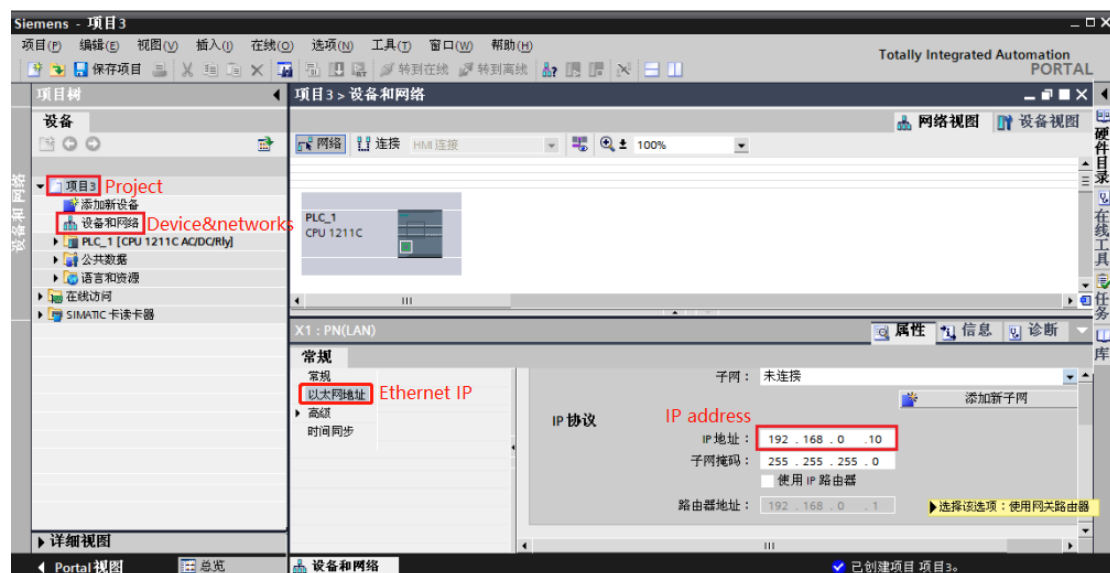

(b) PLC DB, M must be defined in the PLC before using. Click project-program block-add new block, choose data block (DB), the type is global DB, not choose only sign visit. DB number can be auto or manual.

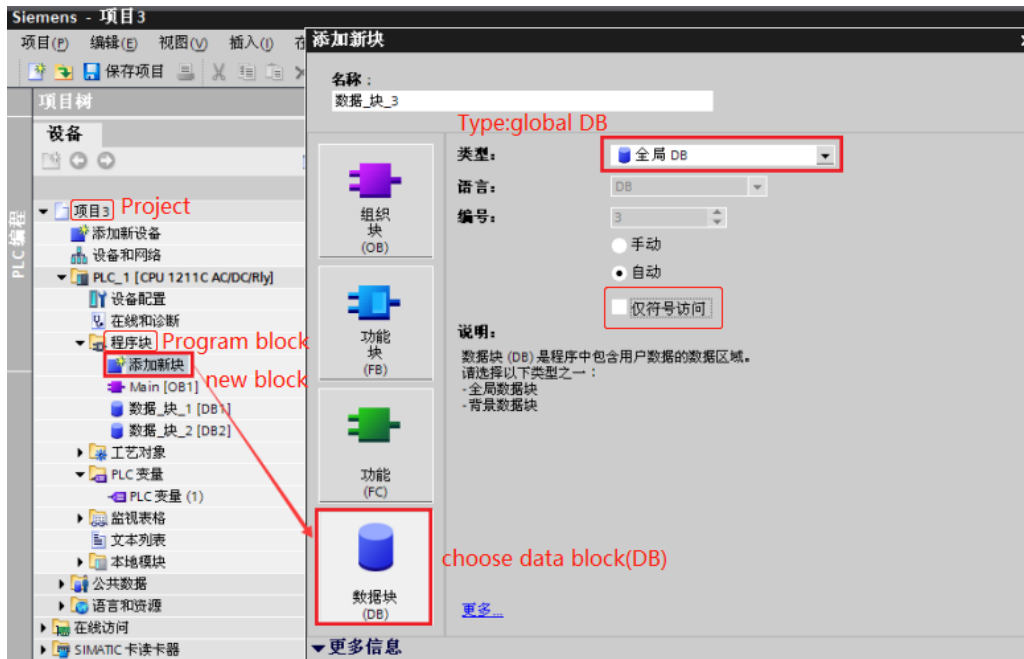

(c) Choose project-program block-data block can define the address in the data block.

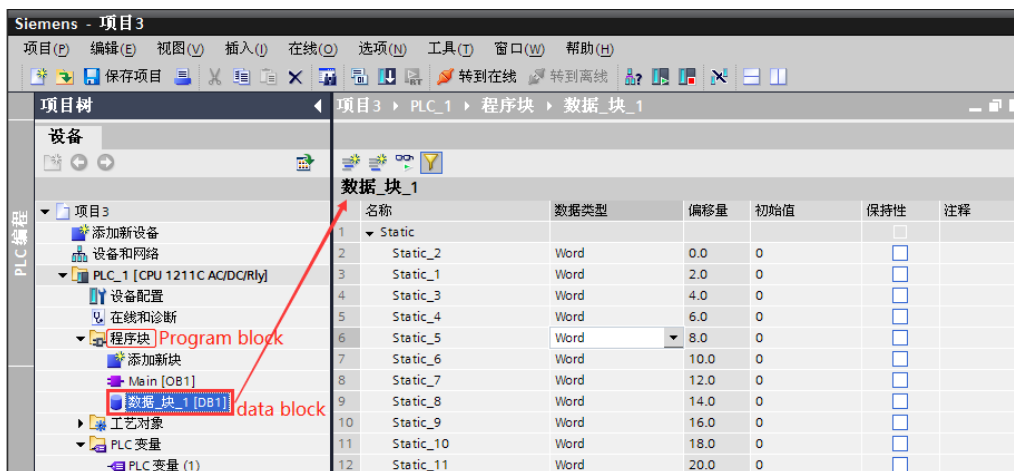

(d) The data block has "optimized block access" by default. Uncheck it. Operation method: select item - program block - data block, right click it and choose properties:

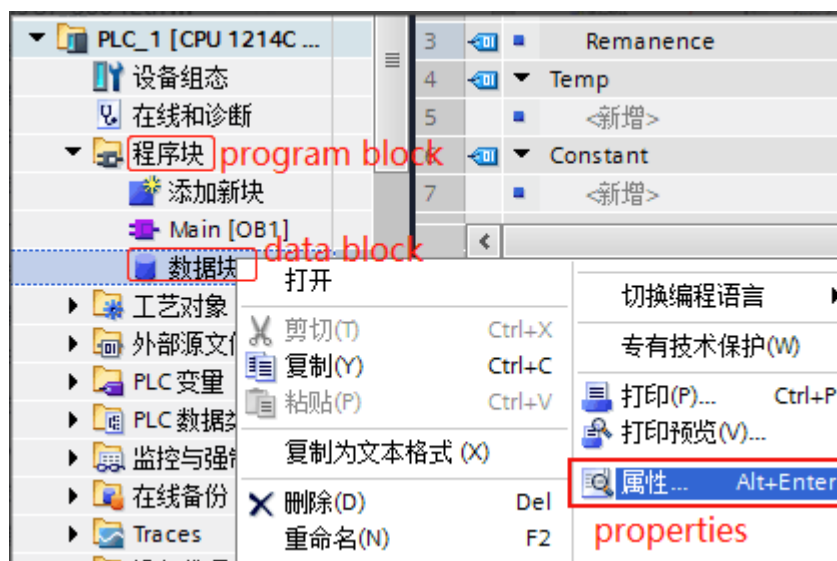

Select the properties in the pop-up window and uncheck the "optimized block access":

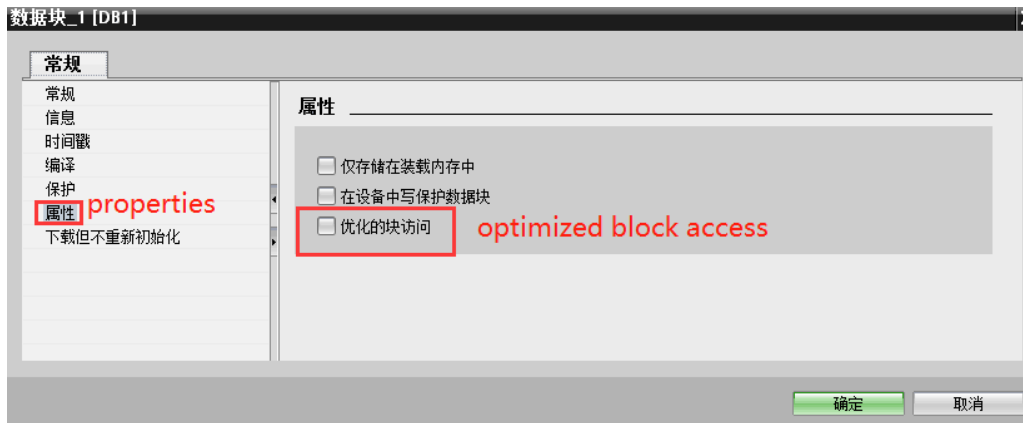

Note: for the software STEP Basic V12 and up version, please release the communication protection:

1. Choose the PLC model in the project tree, right click it, choose properties

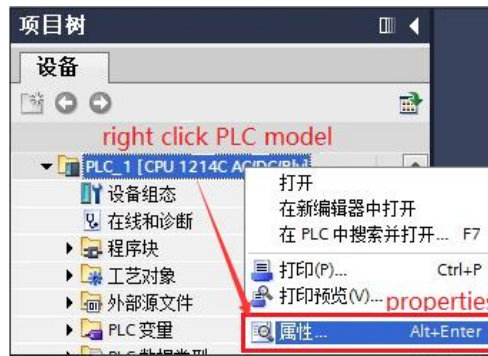

2. Please choose "permit access with PUT/GET communication from remote partner (PLC, HMI, OPC)". Then download the PLC program in the PLC.

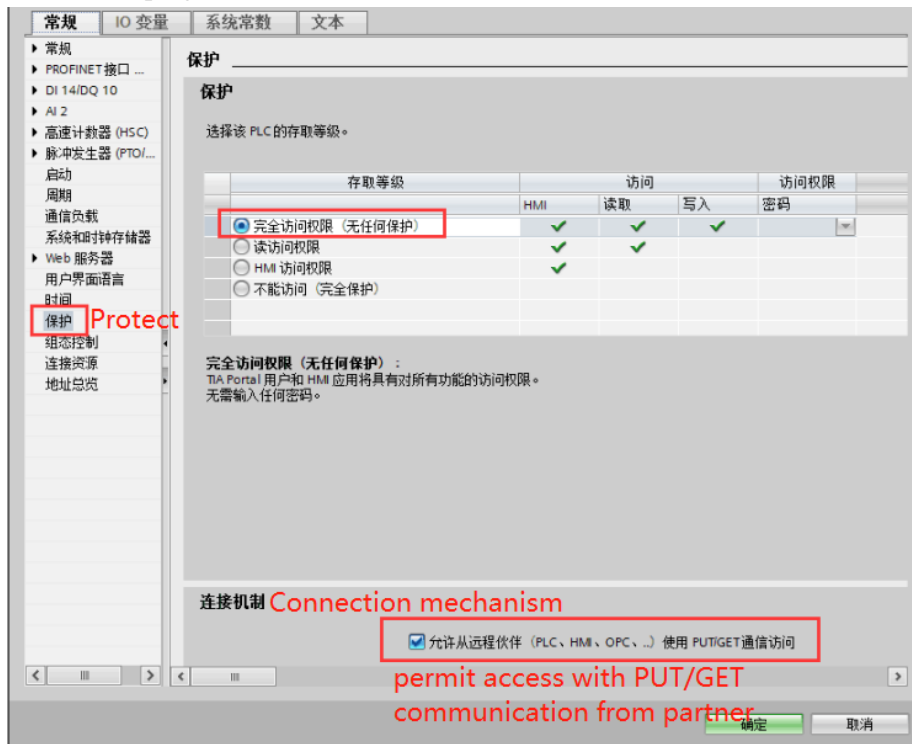

S7-1500 communication settings:

(a) Open project-devices&networks-normal-Ethernet IP, set the PLC IP address:

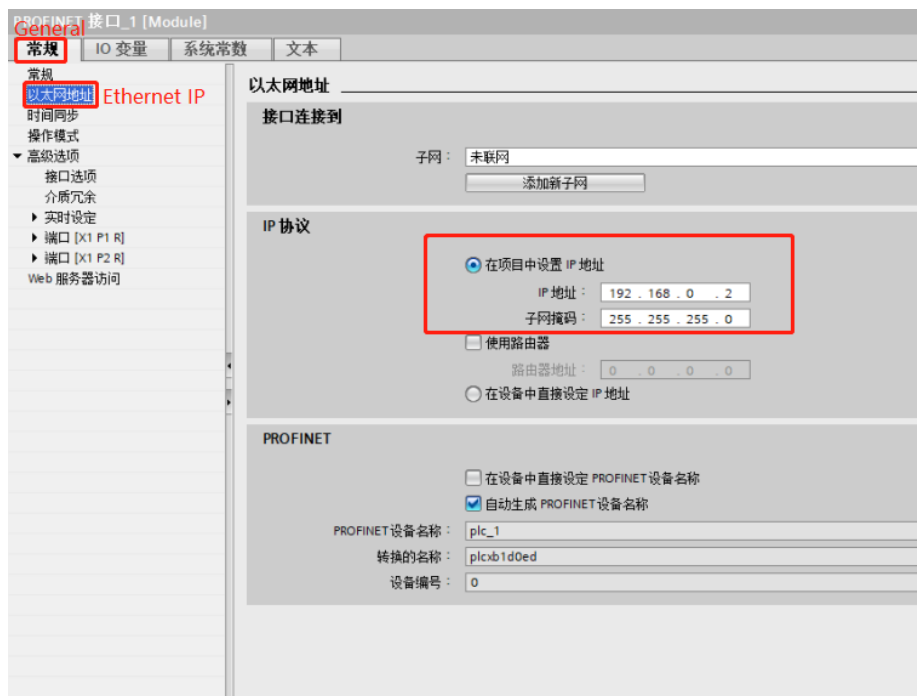

(b) Properties setting check: permit access to DB from OPC UA.

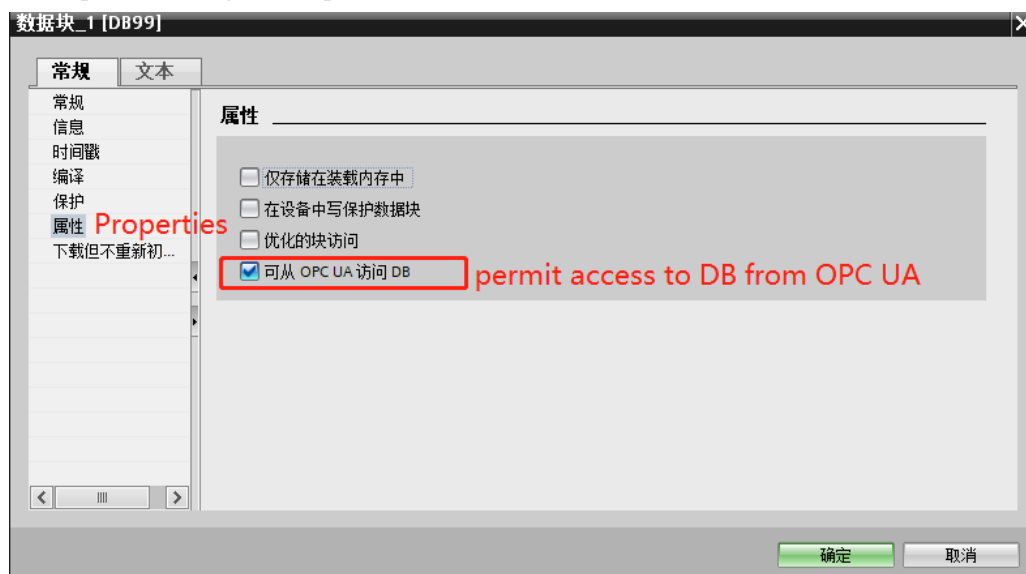

(c) Please choose “permit access with PUT/GET communication from remote partner”.

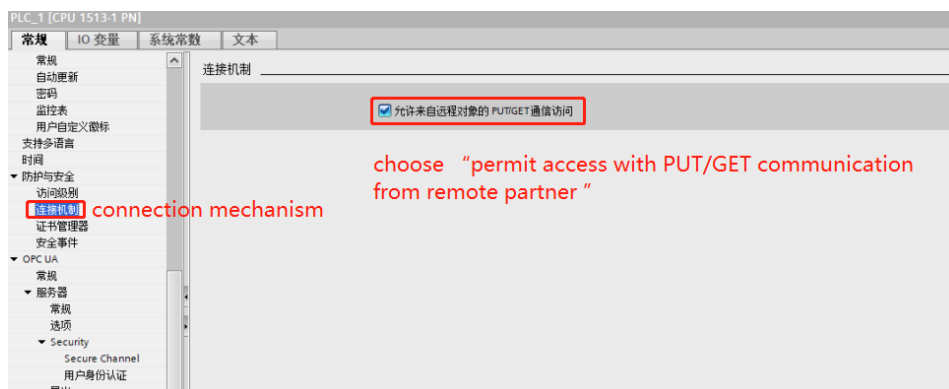

(d) Set access level-HMI access rights/full access.

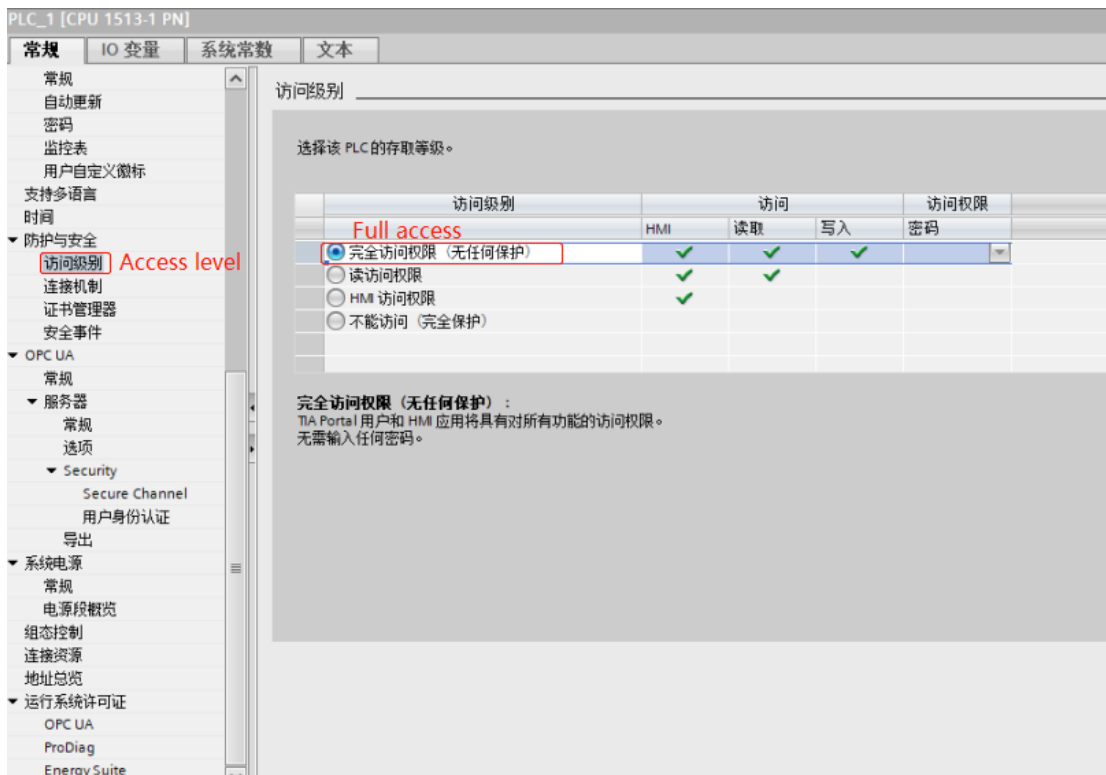
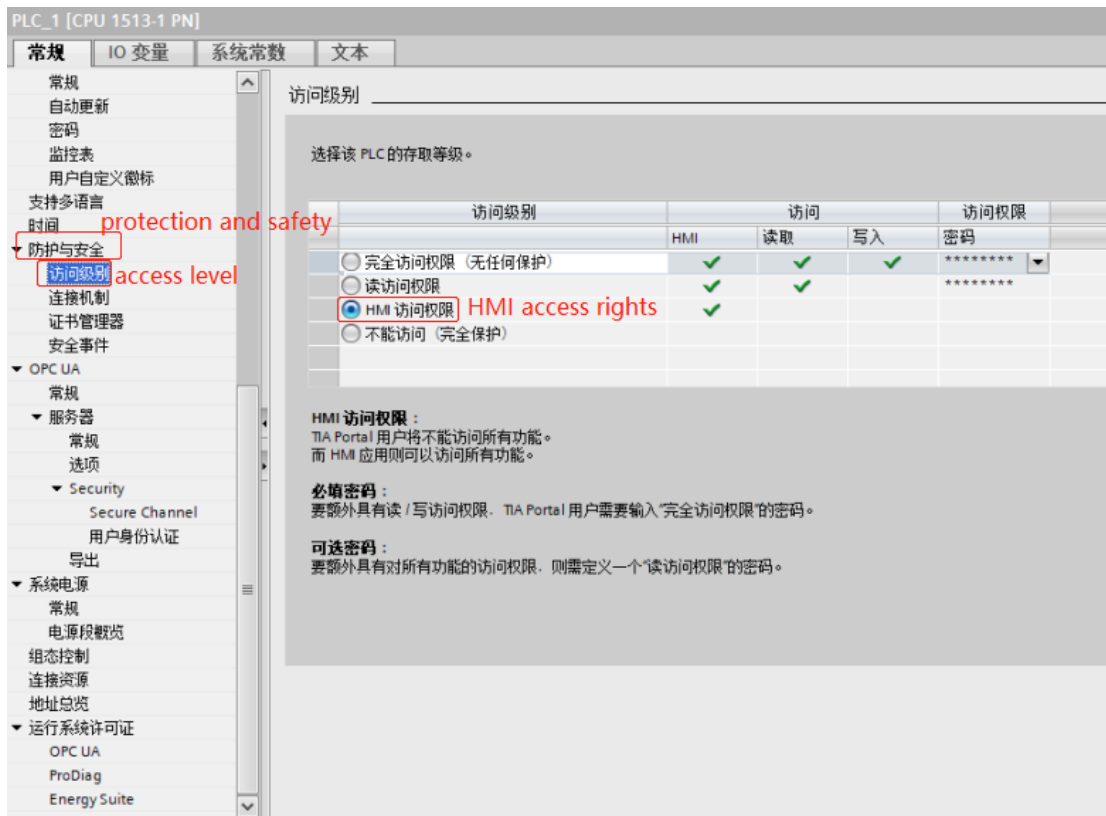

HMI settings:

1. Choose the HMI type TN(-ET), TG(-ET) or TE(-ET), click next, choose Net device in the list, please input the HMI IP address in the own devices.

2. Choose the net device, right click it, choose new, and name it as Siemens S7-300.

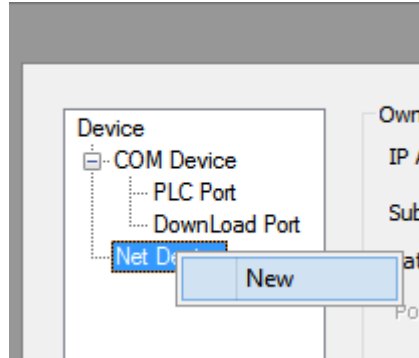

3. Choose Siemens S7-1200 series in the device list, in this example, the PLC IP address is 192.168.0.30, the port is 102 which cannot be changed.

4. For communication with "Siemens S7-1200 series", it is required to check "high-low word exchange", otherwise double words are not used normally.

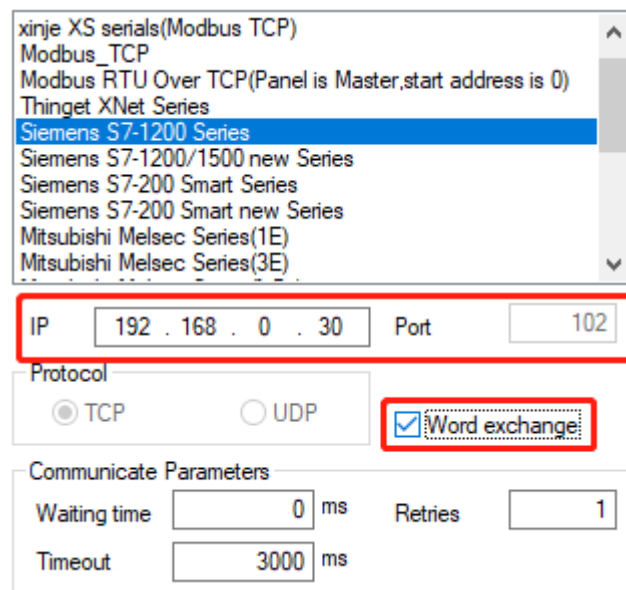

5. The communication parameters please use default settings. If communication status register is chosen, and set to PSW256, then PSW256~PSW259 means communication succeeded times, failed times, overtime times, error times. The register address can be set by user.

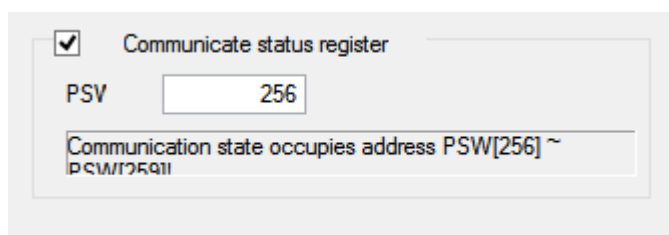

6. Click next to finish the settings. Then enter the screen, for example, put a data input button in the screen, choose the device S7-1200.

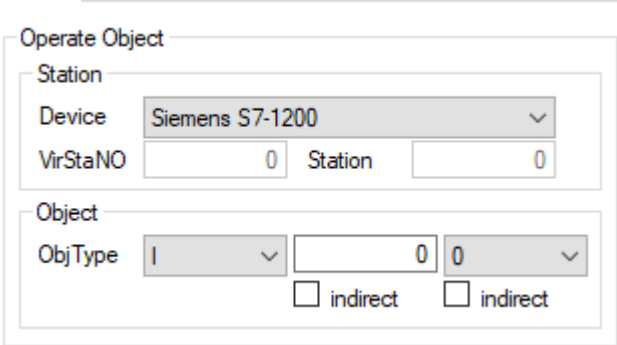

There is no station no. for Siemens S7-1200, set the correct IP address is ok. It can make the networks of multi-HMI-one-PLC, one-HMI-multi-PLC, multi-HMI-multi-PLC.

Note:

- (1) please define the DB and M in the Siemens PLC, otherwise the communication will be error.
- (2) RX/TX lights when the communication is successful. RX/TX is shining when if is finding the network.

2.61.3 Cable making

RJ45 straight through cable (connect HUB) or RJ45 crossover cable:

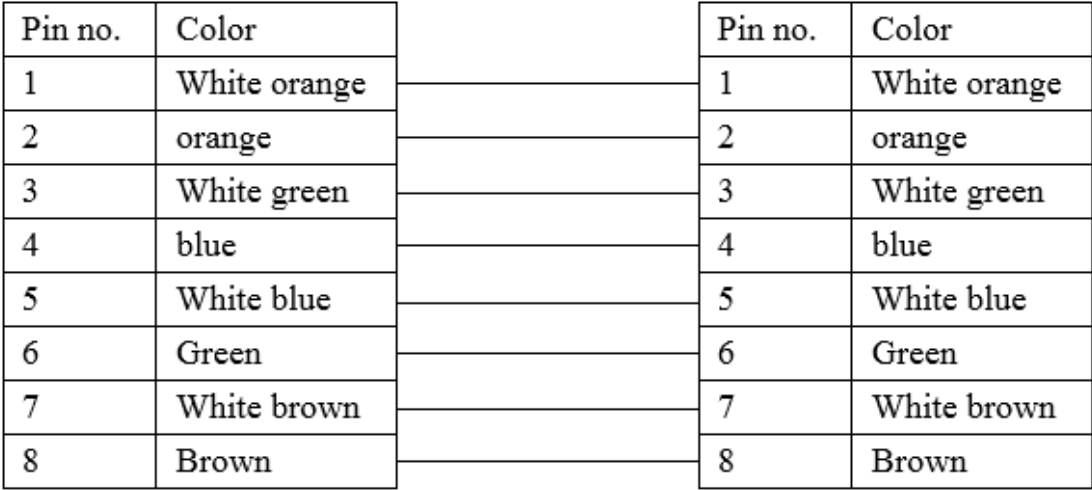

Fig 1

Pin no.	Color		Pin no.	Color
1	White orange	—————	1	White green
2	orange	—————	2	Green
3	White green	—————	3	White orange
4	blue	—————	4	blue
5	White blue	—————	5	White blue
6	Green	—————	6	orange
7	White brown	—————	7	White brown
8	Brown	—————	8	Brown

Fig 2

2.61.4 Device address

PLC type	address	Range	Object type	Explanation
I		0~9999	Byte/Word/DWord	Input register
Q		0~9999	Byte/Word/DWord	Output register
M		0~9999	Byte/Word/DWord	Internal auxiliary register
DB0~DB20		0~9999	Byte/Word/DWord	Data register
I		0.0~9999.7	Bit	Input
Q		0.0~9999.7	Bit	Output
M		0.0~9999.7	Bit	Auxiliary relay
DB0~DB20		0.0~9999.7	Bit	Auxiliary relay

2.62 TAIAN series PLC

2.62.1 Device type

Series	CPU	Connected module	Port	Cable	PLC model in Touchwin software
TAIAN	TP03-20HR-A	RS232 on the CPU Unit	RS232	Fig 1	TAIAN TP03 series
	TP03-30HR-A	RS485 on the CPU Unit	RS485	Fig 2	

2.62.2 Parameters

HMI settings:

Parameters	Recommend settings	Choices of settings	Note
PLC type	TAIAN TP03 series		
Port	RS232	RS232/RS485	
Data bit	8	7/8	
Stop bit	2	1/2	
Parity	No parity	Even /odd /no parity	
Baud rate	19200	4800/38400/9600/115200/19200/187500	
Station no.	1	0-255	

2.62.3 Cable making

RS232 connection:

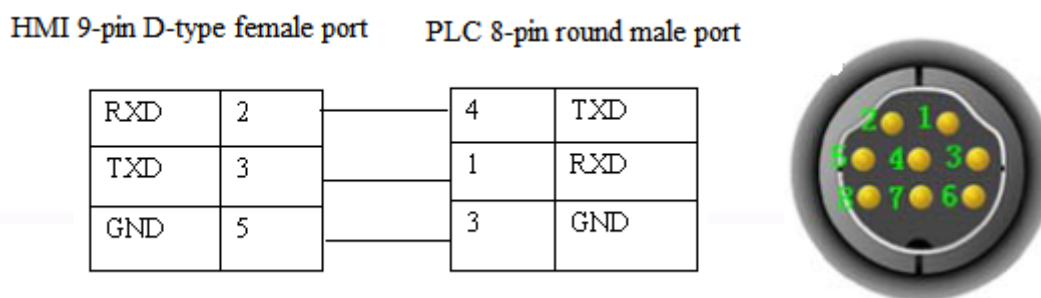

Fig1

RS485 connection:

HMI 9-pin D-type female port PLC RS485 terminal

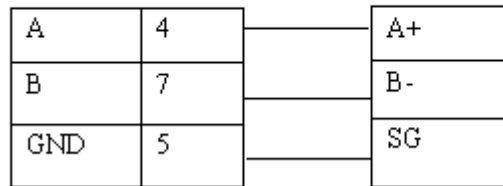

Fig2

2.62.4 Device address

Device address	Range	Data type	Explanation
D	0~8511	Word/DWord	Data register
T	0~511	Word/DWord	Timer
C	0~255	Word/DWord	Counter
X	0~377	Bit	Input
Y	0~377	Bit	Output
M	0~1535	Bit	Auxiliary relay
S	0~1023	Bit	Auxiliary relay
T	0~511	Bit	Timer
M8xxx	0~511	Bit	Auxiliary relay
C	0~255	Bit	Counter
S expansion	1024~4095	Bit	Auxiliary relay
M expansion	1536~7679	Bit	Auxiliary relay

2.63 VIGOR VB/VH series PLC

2.63.1 Device type

Series	CPU	Connected module	Port	Cable	PLC model in Touchwin software
VB	VB0-14M	Direct connect to the CPU	RS232	Fig 1	Vigor VB Series
	VB0-20M				
	VB0-28M	Connect to the extension card	RS232	Fig 2	
	VB0-32M				
	VB1-14MT-D				
VB1-24MT-D	RS422	Fig 3			
VB1-32MTMT-D					
	VB2-16M	RS485	Fig 4		
	VB2-32M				
VH	VH -14MR	Direct connect to the CPU	RS232	Fig 1	

2.63.2 Parameters

HMI:

Parameters	Recommend settings	Choices of settings	Note
PLC type	Vigor VB series PLC		
Port	RS232	RS232/RS485/RS422	
Data bit	7	7 or 8	
Stop bit	1	1 or 2	
Parity	Even parity	Even/odd/no parity	
Baud rate	19200	4800/38400/9600/115200/19200/187500	
Station no.	0	0~255	

The default parameters of Vigor VB series PLC: 19200, 7, 1, even parity, station no.0

2.63.3 Cable making

(a) CPU RS232 USB-A:

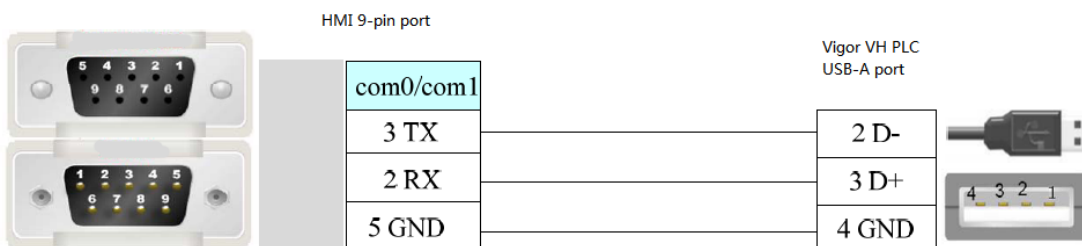

Fig1

(b) CPU direct connection or RS232 extension card:

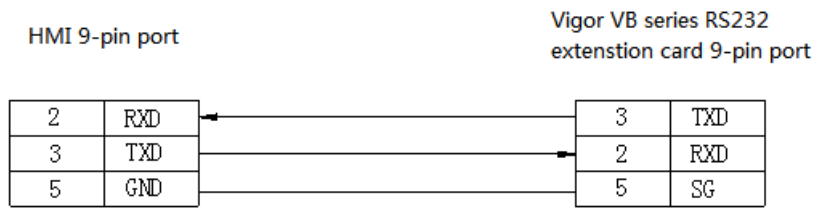

Fig2

(c) CPU direct connection or RS485 extension card:

1. RS422 connection

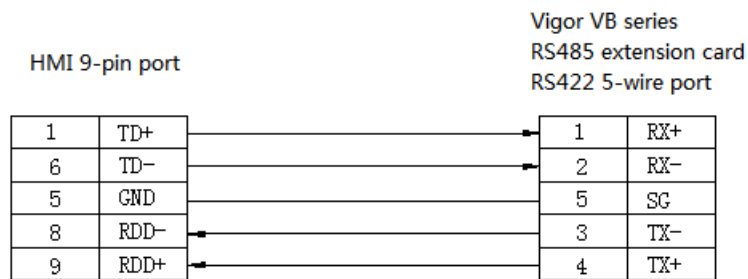

Fig3

2. RS485 connection

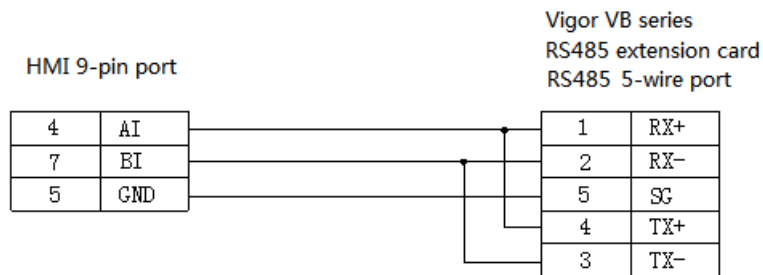

Fig4

2.63.4 Device address

PLC address	Range	Data type	Explanation
X	0~777	Bit	External input coil
Y	0~777	Bit	External output coil
M	0~9255	Bit	Internal auxiliary coil
S	0~999	Bit	Special auxiliary coil
TSTATUS	0~255	Bit	Status of timer
CSTATUS	0~255	Bit	Status of counter
TCOIL	0~255	Bit	Timer coil
CCOIL	0~255	Bit	Counter coil

C16	0~199	Word	16-bit counter
C32	200~255	DWord	32-bit counter
D	0~9255	Word/ DWord	Data register
TW	0~255	Word/ DWord	Current timer value
X	0~777	Word/ DWord	Used as register
Y	0~777	Word/ DWord	Used as register
M	0~9255	Word/ DWord	Used as register
S	0~999	Word/ DWord	Used as register

2.64 VIGOR VS series PLC

2.64.1 Device type

Series	CPU	Connected module	Port	Cable	PLC model in Touchwin software
VS	VS1/2/M/3	Direct connect to CPU	RS232	Fig 1	VIGOR VS series

2.64.2 Parameters

HMI settings

Parameters	Recommend settings	Choices of settings	Note
PLC type	Vigor VS series		
Port	RS232	RS232/RS485/RS422	
Data bit	8	7 or 8	
Stop bit	1	1 or 2	
Parity	Even parity	Even/odd/no parity	
Baud rate	19200	4800/38400/9600/115200/19200/187500	
Station no.	1	0~255	

PLC settings

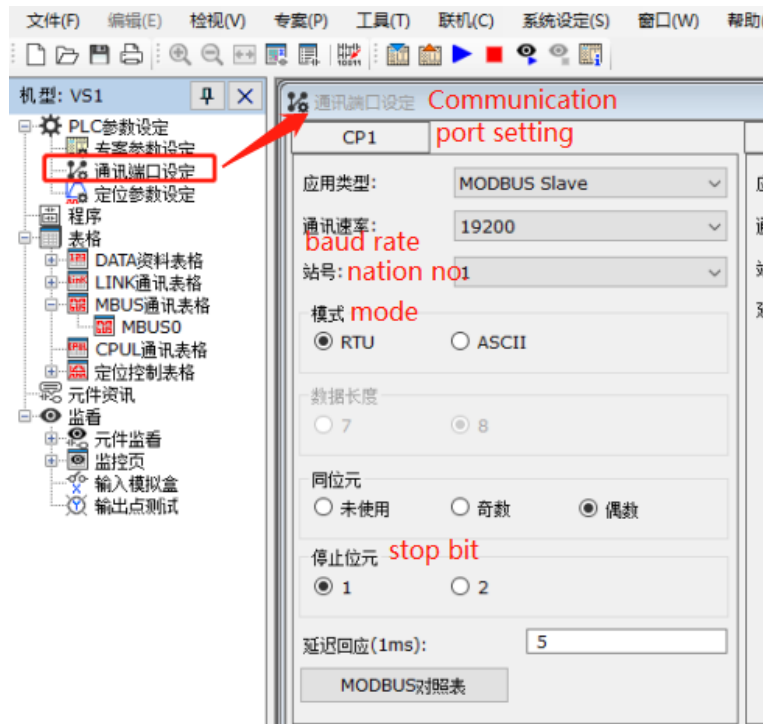

2.64.3 Cable making

(a) CPU RS232 USB-A:

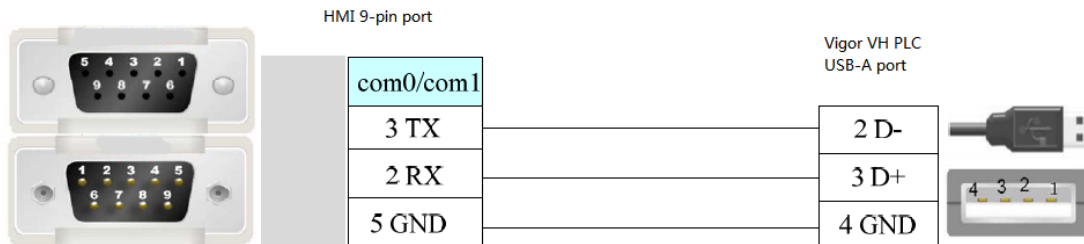

Fig1

(b) CPU direct connection or RS232 extension card:

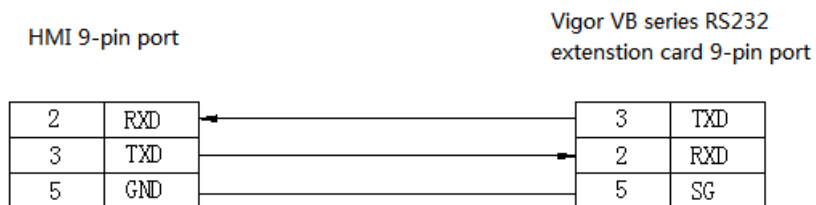

Fig2

(c) CPU direct connection or RS485 extension card:

(1) RS422 connection

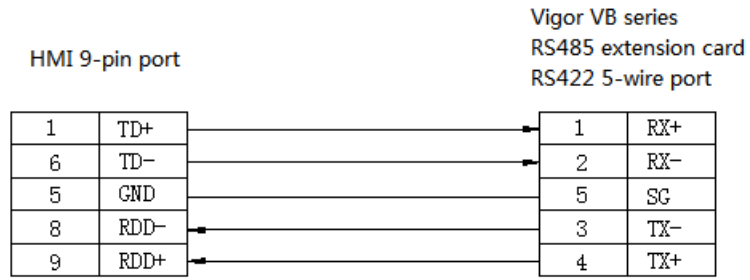

Fig3

(2)RS485 connection

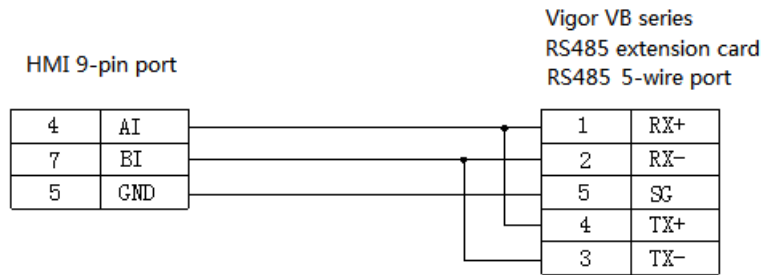

Fig4

2.64.4 Device address

PLC address	Range	Data type	Explanation
X	0~777	Bit	External input coil
Y	0~777	Bit	External output coil
M	0~9255	Bit	Internal auxiliary coil
S	0~999	Bit	Special auxiliary coil
TSTATUS	0~255	Bit	Status of timer
CSTATUS	0~255	Bit	Status of counter
TCOIL	0~255	Bit	Timer coil
CCOIL	0~255	Bit	Counter coil
M	9000~9511	Bit	Special auxiliary coil
C16	0~199	Word	16-bit counter
C32	200~255	DWord	32-bit counter
D	0~9255	Word/ DWord	Data register
T	0~511	Word/ DWord	Timer
C	0~199	Word/ DWord	Used as register
R	0~23999	Word/ DWord	Used as register

2.65 YuDian AI

2.65.1 Device address

Series	Connected module	Port	Cable	PLC model in Touchwin software
AI	RS485 on the cpu unit	RS485	Fig 1	AI series instrument

2.65.2 Parameters

HMI settings:

Parameters	Recommend settings	Choices of settings	Note
PLC type	AI series instrument		
Port	RS485	RS485	
Data bit	8	7/8	
Stop bit	1	1/2	
Parity	No parity	Even /odd /no parity	
Baud rate	9600	4800/38400/9600/115200/19200/187500	
Station no.	129		

Note:

1. The parameters of HMI and meter must be the same.

2. How to set the station no. of meters?

HMI→129 meter→ 1+80H

HMI→130 meter→ 2+80H

2.65.3 Cable making

RS485 connection:

HMI 9-pin D-type female port meter terminal



Fig 1

2.65.4 Device address

Device address	Range	Data type	Explanation
PV	0~100	Read	Measure value
SV	0	Read/write	Set value
MV	0	Read	Output value
Flow meter MV	0	Read	Output value of flow meter
S	0/1	Read	Status bit

2.66 CODESYS PLC

2.66.1 Device type

Series	Connected module	Port	Cable	PLC model in Touchwin software
XS3	RS232 on the CPU Unit	RS485/232	Fig1 or fig 2	MODBUS RTU/TCP (Panel is Master)

2.66.2 Parameters

1.MODBUS RTU

HMI settings:

Parameters	Recommend settings	Choices of settings	Note
PLC type	Modbus RTU		
Port	RS485/232		
Data bit	8		
Stop bit	1		
Parity	Even parity		
Baud rate	9600	9600/19200	
Station no.	1	1~255	

XS3 series PLC settings:

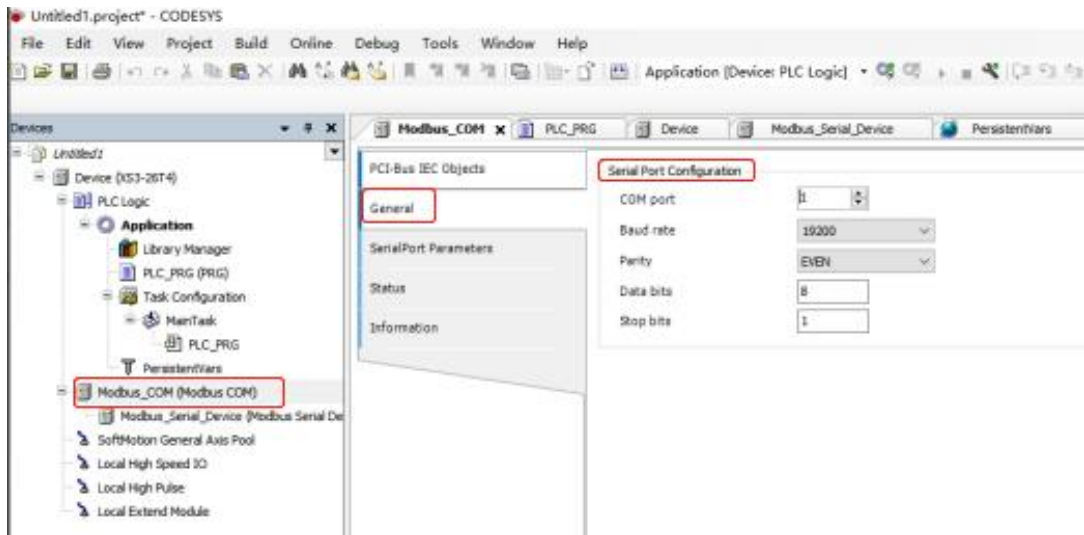

Define variables

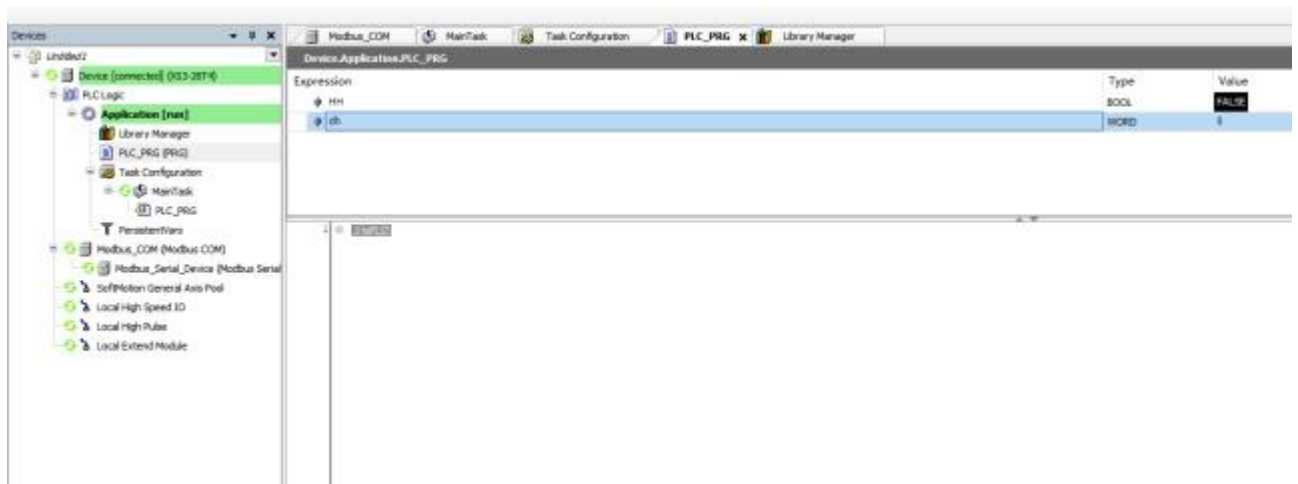
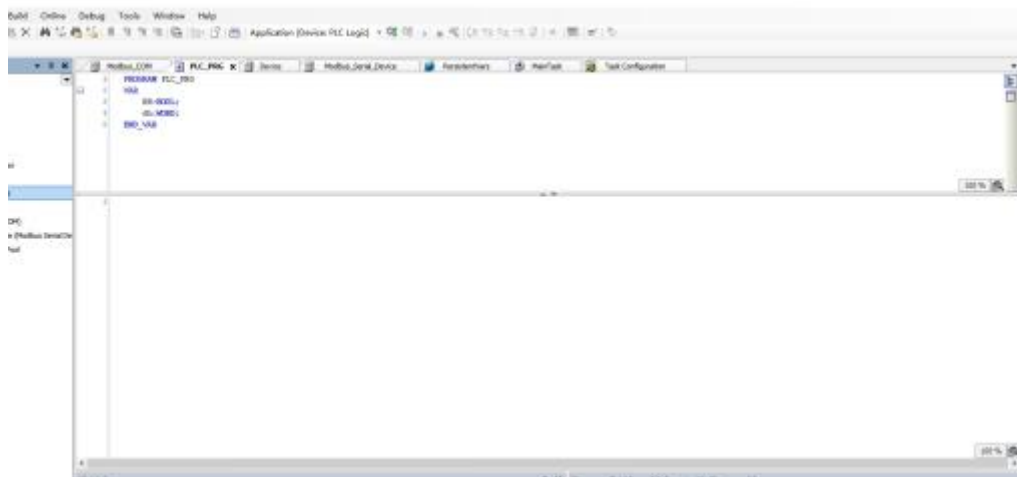

Note: pay attention to the starting address range of the variable.

2.MODBUS TCP

HMI setting:

Series	Port	Cable	PLC model in Touchwin software
XS3	RJ45	Fig 3	MODBUS TCP

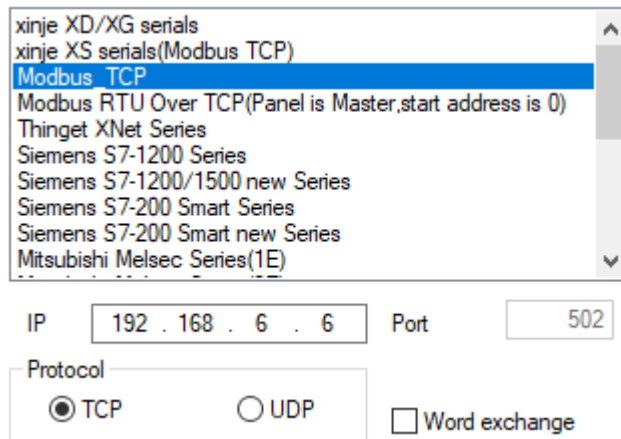
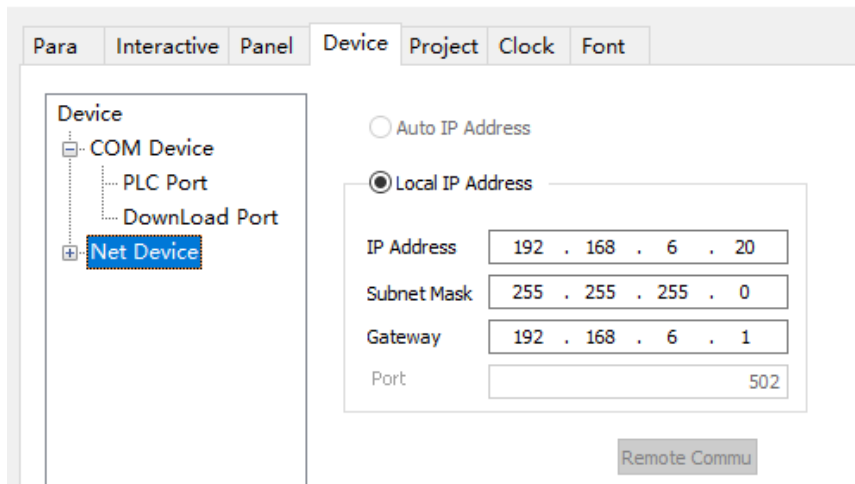

PLC settings:

Create a new Modbus TCP device, and set the corresponding IP and the number of variable addresses.

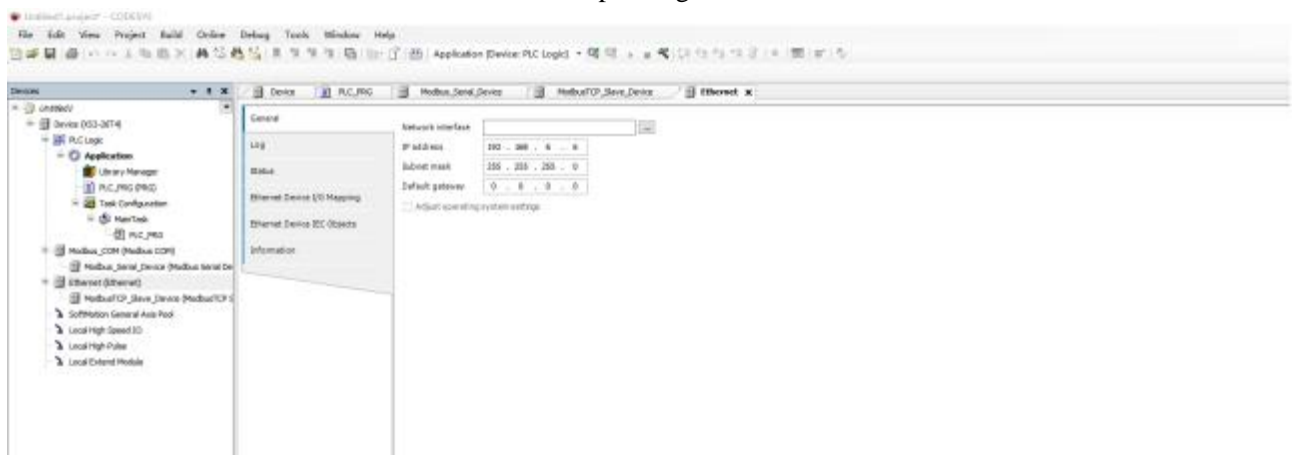

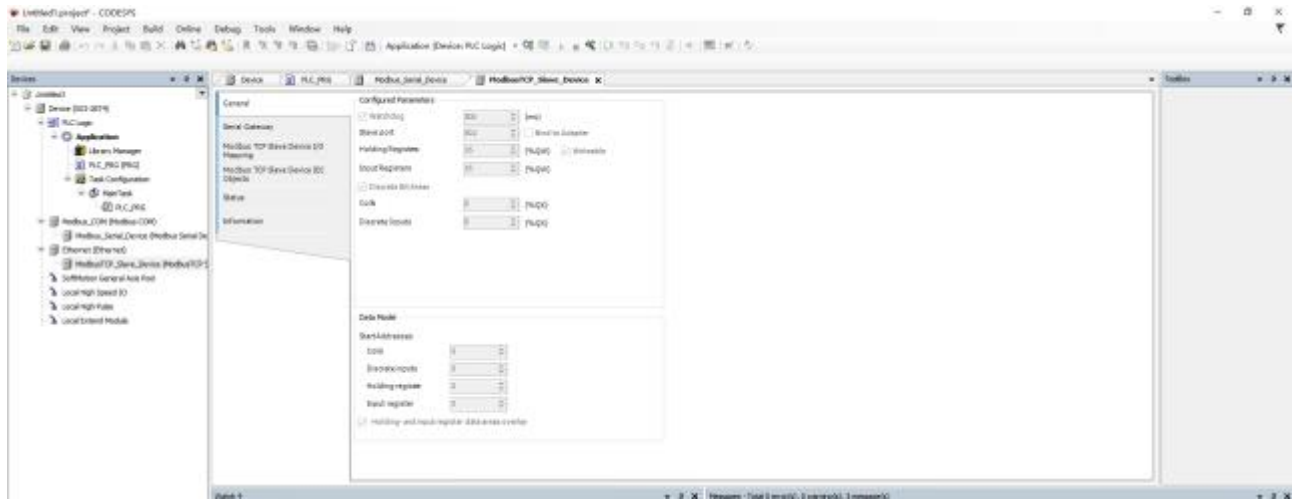

Assign the edited variable to the corresponding address, and then log in to communicate.
 Note: in the touch screen project, the station number of Ethernet device must be 0.

2.66.3 Cable making

(a)RS485

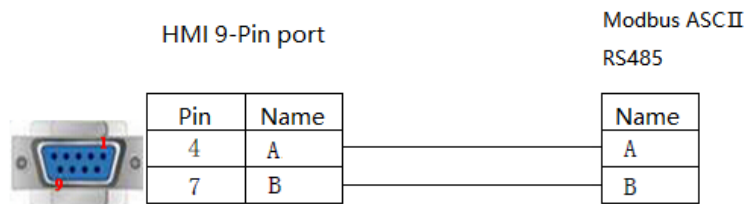

Fig1

(b)RS232

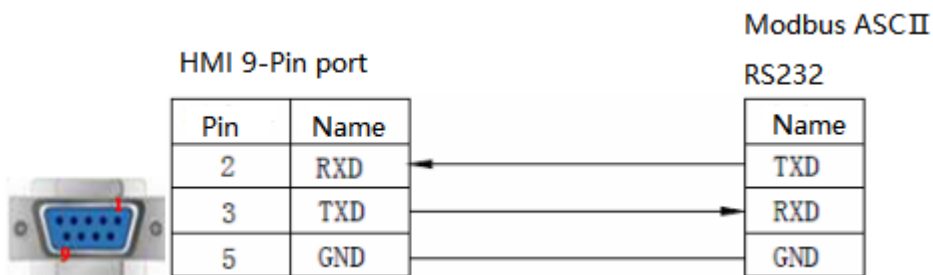

Fig2

(c)RJ45 straight through cable (connect HUB) or RJ45 crossover cable:

Pin no.	Color		Pin no.	Color
1	White orange	—————	1	White orange
2	orange	—————	2	orange
3	White green	—————	3	White green
4	blue	—————	4	blue
5	White blue	—————	5	White blue
6	Green	—————	6	Green
7	White brown	—————	7	White brown
8	Brown	—————	8	Brown

Pin no.	Color		Pin no.	Color
1	White orange	—————	1	White green
2	orange	—————	2	Green
3	White green	—————	3	White orange
4	blue	—————	4	blue
5	White blue	—————	5	White blue
6	Green	—————	6	orange
7	White brown	—————	7	White brown
8	Brown	—————	8	Brown

Fig 3

XINJE



WUXI XINJE ELECTRIC CO., LTD.

No.816, Jianzhu West Road, Binhu
District, Wuxi City, Jiangsu Province,
China

Tel: 86-0510-85134139

Fax: 86-0510-85111290

www.xinje.com

Email: fiona.xinje@vip.163.com