



XD series PLC expansion module

User Manual

WUXI XINJE ELECTRIC CO., LTD.

Data No. PD04 201603022 3.1

This manual includes some basic precautions which you should follow to keep you safe and protect the products. These precautions are underlined with warning triangles in the manual. About other manuals that we do not mention please follow basic electric operating rules.

Precautions



Please follow the precautions. If not, it may lead the control system incorrect or abnormal, even cause fortune lose.

Correct Application



The models could only be used according to the manual, and an only be used along with the peripheral equipment recognized or recommended by X Company. They could only work normally in the condition of be transported, kept and installed correctly, also please operate and maintain them according to the recommendation.

WUXI XINJE ELECTRIC CO., LTD. Copyright reserved
Without exact paper file allowance, copy, translate or using the manual is not allowed. Disobey this, people should take the responsibility of loss. We reserve all the right of expansions and their design patent.

Duty Declare

We have checked the manual; its content fits the hardware and software of the products. As mistakes are unavoidable, we couldn't promise all correct. However, we would check the data in the manual frequently, and in the next edition, we will correct the necessary information. Your recommendation would be highly appreciated

Catalog

1. MODULES INTRODUCTION	8
1-1. MODULE TYPE AND CONFIGURATION	8
1-2. DIMENSIONS	2
1-3. MODULE PART NAME AND FUNCTION	3
1-4. GENERAL SPECIFICATIONS	3
1-5. INSTALLATION	4
1-6. CONFIGURE THE MODULE	6
2. ANALOG INPUT MODULE XD-E8AD	7
2-1. SPECIFICATION	7
2-2. TERMINALS	8
2-3. I/O DISTRIBUTION	8
2-4. WORKING MODE	14
2-5. EXTERIOR CONNECTION	16
2-6. AD CONVERSION DIAGRAM	18
2-7. PROGRAM APPLICATION	19
3. ANALOG INPUT/OUTPUT MODULE XD-E4AD2DA	20
3-1. SPECIFICATION	20
3-2. TERMINALS	21
3-3. THE ASSIGNMENT OF I/O ADDRESS	21
3-4. WORKING MODE	27
3-5. EXTERIOR CONNECTION	29
3-6. AD CONVERSION DIAGRAM	31
3-7. PROGRAMMING	32
4. ANALOG INPUT MODULE XD-E4AD	33
4-1. SPECIFICATIONS	33
4-2. TERMINALS	33
4-3. I/O ADDRESS ASSIGNMENT	34
4-4. WORKING MODE	38
4-5. EXTERIOR CONNECTION	40
4-6. AD CONVERSION DIAGRAM	42
4-7. PROGRAMMING	42
5. ANALOG OUTPUT MODULE XD-E2DA	43
5-1. SPECIFICATIONS	43
5-2. TERMINALS	44
5-3. I/O ADDRESS ASSIGNMENT	44
5-4. WORKING MODE	47
5-5. EXTERNAL CONNECTION	49
5-6. DA CONVERSION DIAGRAM	50
5-7. PROGRAMMING	50

6. 1 CHANNEL PRESSURE MODULE XD-E1WT-A.....	51
6-1. FEATURES	51
6-2. TERMINALS.....	52
6-3. EXTERNAL CONNECTION	52
6-4. WEIGHING SYSTEM.....	53
6-5. MODULE FUNCTIONS	54
6-5-1. Pressure sensor.....	54
6-6. I/O ADDRESS	54
6-7. WORKING MODE	55
6-8. MODULE SETTING.....	57
6-9. INSTRUCTION FROM AND TO	59
6-10. A/D TRANSFORMATION DIAGRAM.....	60
6-11. APPLICATION PROGRAM.....	60
7. 2 CHANNELS PRESSURE MODULE XD-E2WT-A	62
7-1. FEATURES	62
7-2. TERMINALS.....	63
7-3. EXTERNAL CONNECTION	63
7-4. WEIGHING SYSTEM.....	65
7-5. MODULE FUNCTIONS	65
7-5-1. Pressure sensor.....	66
7-6. I/O ADDRESS	66
7-7. WORKING MODE	68
7-8. MODULE SETTING.....	70
7-9. INSTRUCTION FROM AND TO	71
7-10. A/D TRANSFORMATION DIAGRAM.....	73
7-11. APPLICATION PROGRAM.....	73
8. PT100 TEMPERATURE CONTROL MODULE XD-E6PT-P.....	75
8-1. SPECIFICATION.....	75
8-2. TERMINALS.....	76
8-3. I/O ADDRESS ASSIGNMENT.....	76
8-4. WORKING MODE	81
8-5. EXTERIOR CONNECTION	83
8-6. PROGRAMMING.....	84
9. K TYPE THERMOCOUPLE TEMPERATURE CONTROL MODULE XD-E6TC-P.....	87
9-1. SPECIFICATION.....	87
9-2. TERMINALS.....	88
9-3. I/O ADDRESS ASSIGNMENT.....	89
9-4. WORKING MODE	93
9-5. EXTERIOR CONNECTION	95
9-6. PROGRAMMING.....	96
10. I/O EXPANSION MODULE XD-ENXMY.....	98

10-1. SPECIFICATIONS	98
10-2. TERMINALS	99
10-3. I/O ADDRESS ASSIGNMENT	101
10-4. EXTERNAL CONNECTION	111
10-5. MODULE PARAMETERS	113
10-6. APPLICATIONS	117
11. ANALOG INPUT/OUTPUT MODULE XD-E4AD2DA-B	121
11-1. SPECIFICATION	121
11-2. TERMINALS	122
11-3. THE ASSIGNMENT OF I/O ADDRESS	123
11-4. WORKING MODE	128
11-5. EXTERIOR CONNECTION	130
11-6. AD CONVERSION DIAGRAM	131
11-7. PROGRAMMING	132
12. ANALOG OUTPUT MODULE XD-E4DA	133
12-1. SPECIFICATIONS	133
12-2. TERMINALS	133
12-3. I/O ADDRESS ASSIGNMENT	134
12-4. WORKING MODE	138
12-5. EXTERNAL CONNECTION	140
12-6. DA CONVERSION DIAGRAM	141
12-7. PROGRAMMING	141
13. 4 CHANNELS PRESSURE MODULE XD-E4WT-A	142
13-1. FEATURES	142
13-2. TERMINALS	143
13-3. EXTERNAL CONNECTION	143
13-4. WEIGHING SYSTEM	145
13-5. MODULE FUNCTIONS	145
13-5-1. Pressure sensor	145
13-6. I/O ADDRESS	146
13-7. WORKING MODE	149
13-8. MODULE SETTING	151
13-9. INSTRUCTION FROM AND TO	152
13-10. A/D TRANSFORMATION DIAGRAM	154
13-11. APPLICATION PROGRAM	154
14. ANALOG INPUT MODULE XD-E8AD-A	156
14-1. SPECIFICATION	156
14-2. TERMINALS	156
14-3. I/O DISTRIBUTION	157
14-4. WORKING MODE	163
14-5. EXTERIOR CONNECTION	166

14-6. AD CONVERSION DIAGRAM	167
14-7. PROGRAM APPLICATION.....	167
15. ANALOG INPUT MODULE XD-E8AD-V	169
15-1. SPECIFICATION.....	169
15-2. TERMINALS.....	169
15-3. I/O DISTRIBUTION.....	170
15-4. WORKING MODE.....	176
15-5. EXTERIOR CONNECTION	179
15-6. AD CONVERSION DIAGRAM	179
15-7. PROGRAM APPLICATION.....	180
16. X-NET RELAY MODULE JR-EH	181
16-1. SUITABLE CONDITION	181
16-2. FEATURES	181
16-3. APPEARANCE.....	181
16-4. BAUD RATE.....	182
16-5. LED.....	182
16-6. WIRING DIAGRAM.....	182
16-7. MODULE NAMING RULE.....	183
16-8. DIMENSION.....	183
17. 4 CHANNELS PRESSURE MODULE XD-E4WT-C.....	183
17-1. FEATURES	183
17-2. TERMINALS.....	184
17-3. EXTERNAL CONNECTION.....	185
17-4. WEIGHING SYSTEM.....	187
17-5. MODULE FUNCTIONS	187
17-5-1. Pressure sensor.....	187
17-6. I/O ADDRESS	188
17-7. WORKING MODE	192
17-8. MODULE SETTING.....	194
17-9. MODULE ERROR INFO	196
17-10. INSTRUCTION FROM AND TO	196
17-11. AD TRANSFORMATION DIAGRAM.....	197
17-12. APPLICATION PROGRAM.....	198
18. 2 CHANNELS PRESSURE MODULE XD-E2WT-B.....	200
18-1. FEATURES	200
18-2. TERMINALS.....	201
18-3. EXTERNAL CONNECTION.....	202
18-4. WEIGHING SYSTEM.....	203
18-5. MODULE FUNCTIONS	204
18-5-1. Pressure sensor.....	204
18-6. I/O ADDRESS.....	204

18-7. WORKING MODE	206
18-8. MODULE SETTING	208
18-9. INSTRUCTION FROM AND TO	209
18-10. A/D TRANSFORMATION DIAGRAM.....	210
18-11. APPLICATION PROGRAM.....	211
19. 1 CHANNELS PRESSURE MODULE XD-E1WT-C.....	212
19-1. FEATURES	212
19-2. TERMINALS.....	213
19-3. EXTERNAL CONNECTION.....	213
19-4. WEIGHING SYSTEM	214
19-5. MODULE FUNCTIONS	215
19-5-1. <i>Pressure sensor</i>	215
19-6. I/O ADDRESS	215
19-7. WORKING MODE	217
19-8. MODULE SETTING	219
19-9. MODULE ERROR INFO	221
19-10. INSTRUCTION FROM AND TO	222
19-11. AD TRANSFORMATION DIAGRAM.....	223
19-12. APPLICATION PROGRAM.....	223
20. 2 CHANNELS PRESSURE MODULE XD-E2WT-C.....	225
20-1. FEATURES	225
20-2. TERMINALS.....	226
20-3. EXTERNAL CONNECTION.....	227
20-4. WEIGHING SYSTEM	228
20-5. MODULE FUNCTIONS	228
20-5-1. <i>Pressure sensor</i>	229
20-6. I/O ADDRESS	229
20-7. WORKING MODE	232
20-8. MODULE SETTING.....	234
20-9. MODULE ERROR INFO	236
20-10. INSTRUCTION FROM AND TO	236
20-11. AD TRANSFORMATION DIAGRAM.....	237
20-12. APPLICATION PROGRAM.....	238

1. Modules introduction

1-1. Module type and configuration

XD series PLCs not only have strong functions of logic operation, data operation, high speed processing etc. but also A/D, D/A conversion, PID function. With the expansions of analog input module, analog output module, temperature control module etc. XD series PLCs are widely used in the control system of temperature, flow, liquid level, pressure.

Module type and names

The detailed information is:

Model	Function
XD-EnXmY	N points input, m points output, PNP/NPN input, relay/transistor output
XD-E4AD2DA	4 channels analog input (14bits); 2 channels analog output (12bits); input and output are all current/voltage selectable
XD-E4AD2DA-B	4 channels analog input (14bits), current/voltage selectable; 2 channels voltage output (12bits), -10V~10V, -5V~5V selectable;
XD-E4AD	4 channels analog input (14 bits), current/voltage selectable
XD-E8AD	8 channels analog input (14 bits), current/voltage selectable
XD-E2DA	2 channels analog output (12 bits), current/voltage selectable
XD-E4DA	4 channels analog output (12 bits), current/voltage selectable
XD-E1WT-A	1 channel pressure control module
XD-E2WT-A	2 channel pressure control module
XD-E4WT-A	4 channel pressure control module
XD-E6PT-P	6 channels PT100 temperature control module, with PID function
XD-E6TC-P	6 channels thermocouple temperature control module, with PID function

Module configuration

XD series expansion modules can be connected to the right side of PLC:

- Digital input, output terminal no. is octal number.
- Analog input, output terminal no. is decimal number.
- Up to 10 expansion modules can be connected to XD3 series PLC.
- Up to 16 expansion modules can be connect to XDM series PLC.

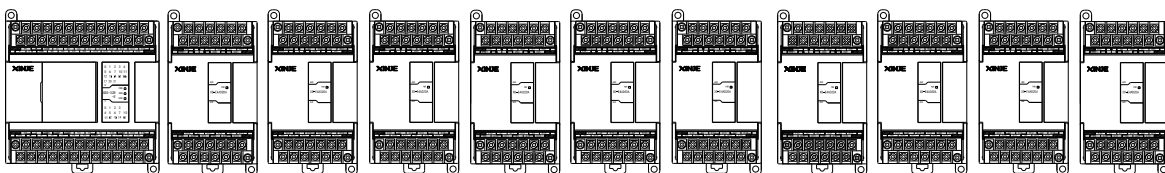

1-2. Dimensions

Analog, temperature, pressure modules, 8/16 points I/O modules: (dimension: mm)

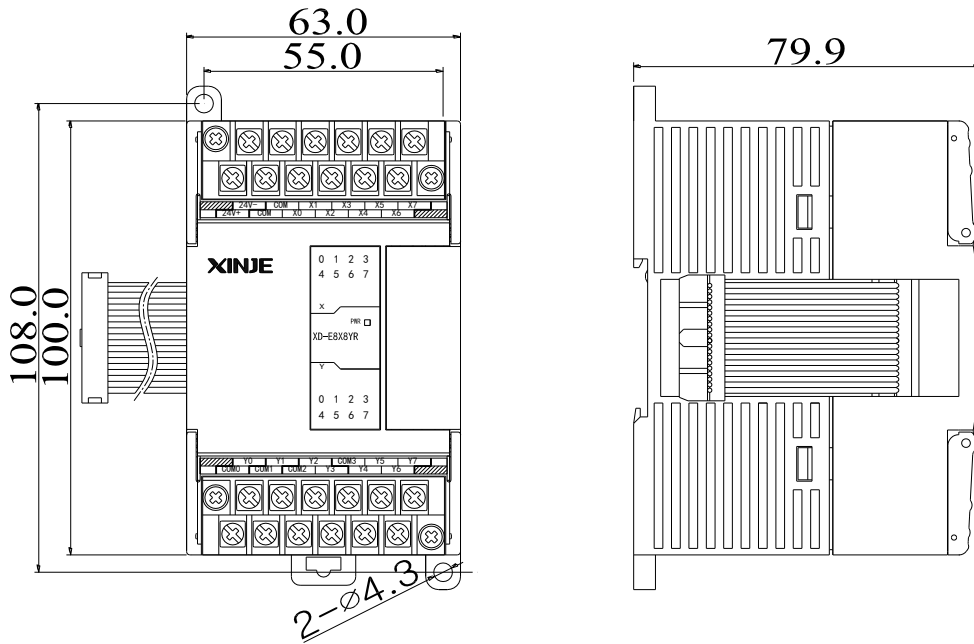

32 points I/O modules: (dimension: mm)

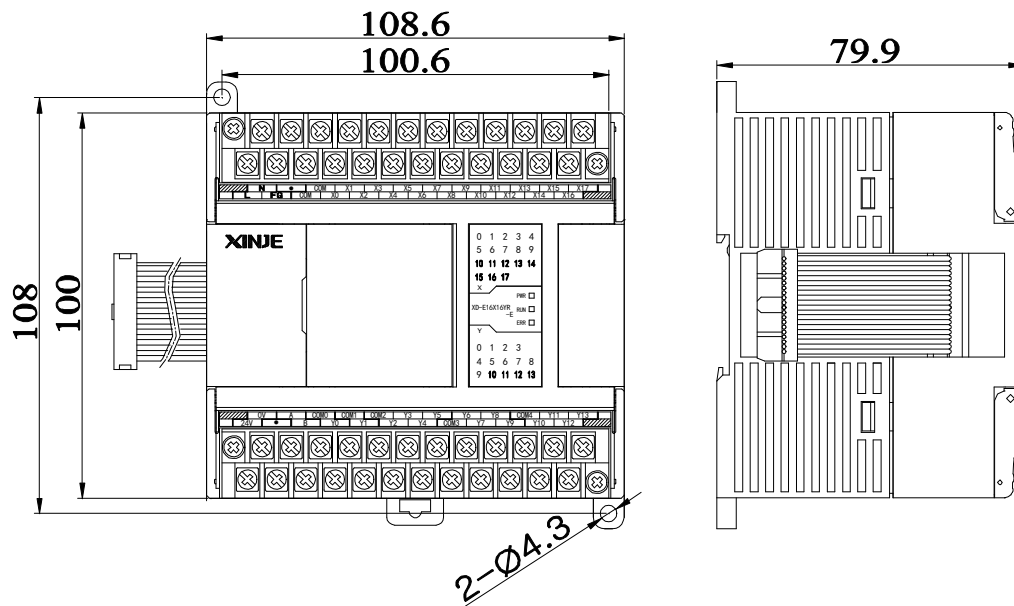

1-3. Module part name and function

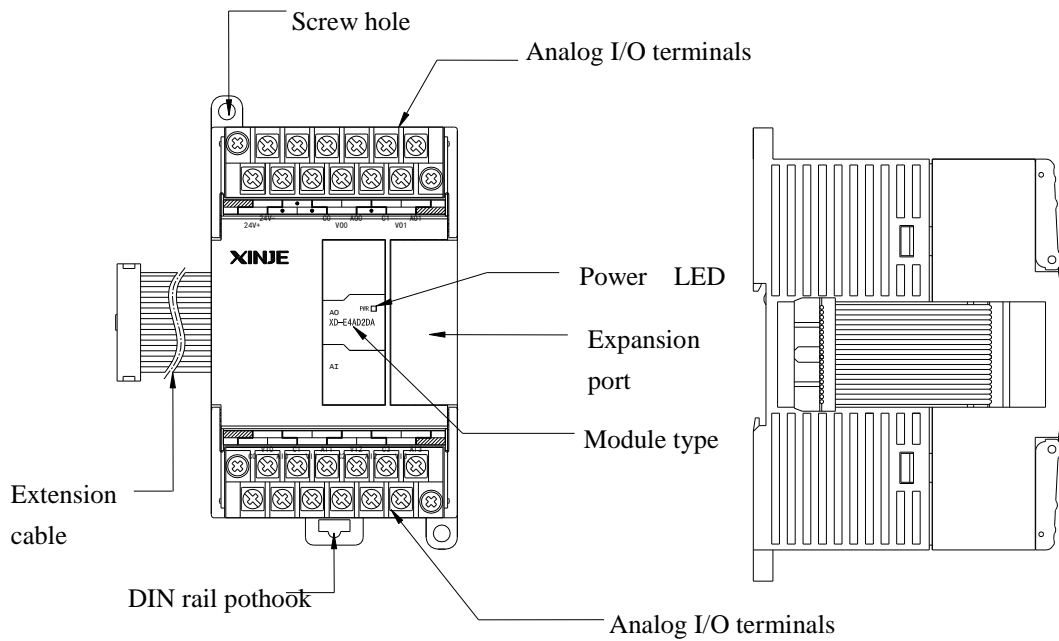

Name	Function
Power LED	The LED lights when the power supply is on
Module type	The type of expansion module
Expansion port	To connect the expansion module
Analog I/O terminals	To connect to analog input and output, the terminals are knock-down
DIN rail pothook	To mount the module, pull down the pothook to take away the module
Screw hole	Use M3 screw
Expansion cable	To connect the expansion module

1-4. General specifications

Operating Environment	No corrosive gas
Ambient Temperature	0°C~60°C
Store Temperature	-20~70°C
Ambient Humidity	5~95% RH
Store Humidity	5~95% RH
Installation	Can be fixed with M3 screw or directly installed on DIN46277 rail (width: 35mm)

1-5. Installation

XD series expansion module can be connected to the right side of PLC. Fix the module on the DIN46277 rail or with screw M3.

DIN46277 rail:

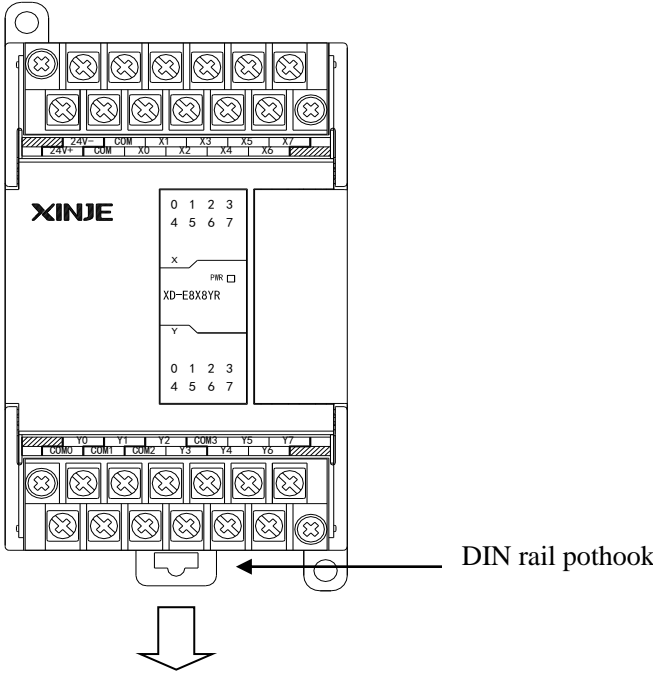

The module can be mounted on the DIN46277 rail (width 35mm). Pull down the DIN rail pothook to uninstall the module.

Direct installation: put the screw (M3) to fix the module.

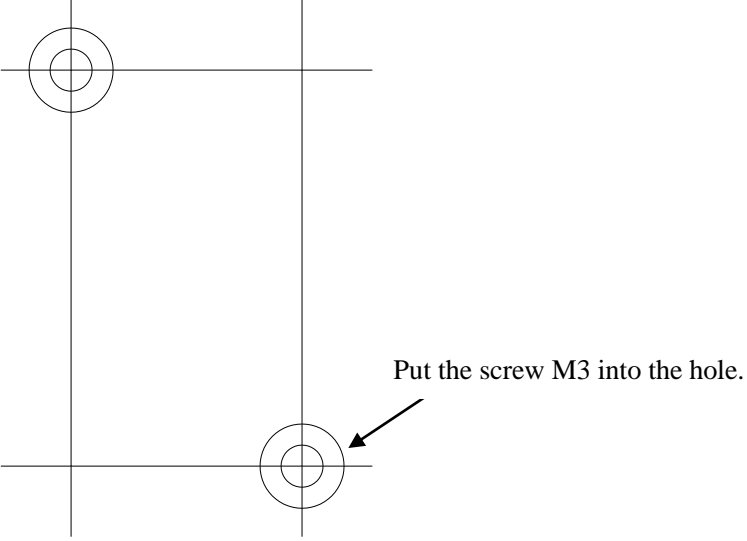

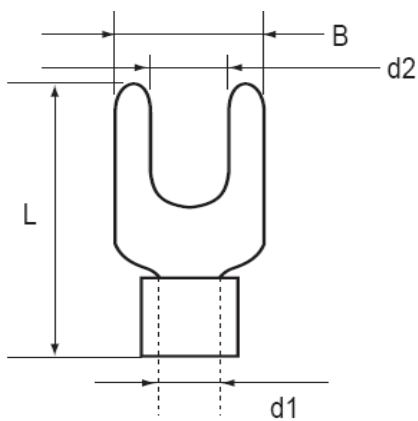

Terminal wiring:

■ Y terminal

Y terminal dimension

B: Y outer dimension

d1: Outer diameter connecting to the wire

d2: Internal diameter (press the screw)

L: Whole length

Suitable dimension:

B: below 6mm L: below 13mm

d2: below 3.2mm

■ Wiring method

A. Cut off the power supply

B. Open the front cover

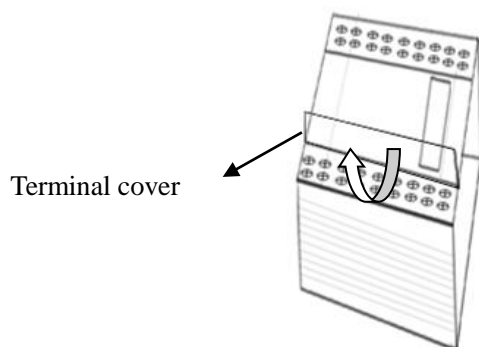

C. Put the terminal of signal wire on the I/O terminal tightens the screw.

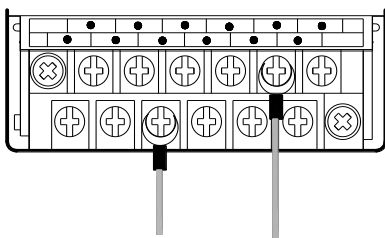

D. Close the I/O terminal cover

Notes:

1. Confirm the specification of the module
2. The scraps cannot fall into the module when wiring
3. Before wiring, confirm the specifications of module and device again
4. Make sure the wire connection is firm, otherwise data incorrectness and circuit shorting will happen
5. Cut the power before Installation and wiring

1-6. Configure the module

Before using the expansion module, please configure the module in XDPpro software. Next we will introduce the configuration steps. Take XD-E4AD2DA as an example.

- A. Open the XDPpro software, click Configure/expansion module settings.

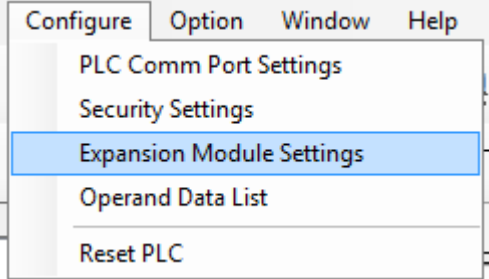

- B. Choose the module type and channel parameters in the following window. Then click write to PLC.

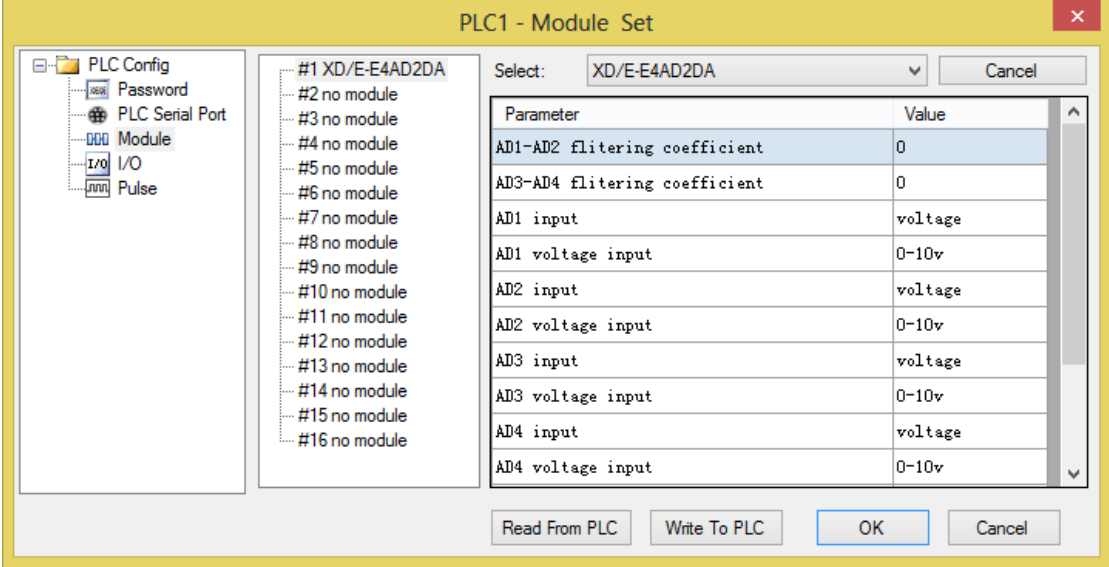

- C. Cut the PLC power supply and give the power again to make the setting effective.

2. Analog input module XD-E8AD

2-1. Specification

XD-E8AD transform the analog value (current or voltage input) to digital value and send to PLC registers.

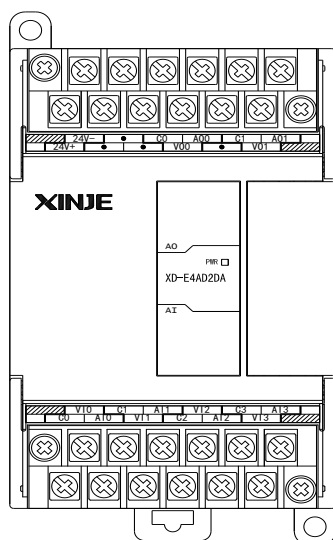

- 14 bits high precision analog input
- 8 channels analog input: The first four channels are voltage input. The last 4 channels are current input
- As special function module of XD3, up to 10 models can be connected.
- XDM can connect 16 modules

Items	Voltage input (0CH~3CH)		Current input (4CH~7CH)	
	Analog input range	0~5V, 0~10V	-10~10V, -5~5V	0~20mA, 4~20mA
Max input range	DC ± 15V		0~40mA	
Digital output range	14 bits binary data (0~16383)	14 bits binary data (-8192~8191)	14 bits binary data (0~16383)	14 bits binary data (-8192~8191)
Resolution	1/16383(14Bit)			
Integrate Precision	1%			
Conversion speed	2ms per channel			
Analog power supply	DC24V ±10%,150mA			
Installation	Can be fixed with screw M3 or directly installed on orbit of DIN46277 (width: 35mm)			
Dimension	63mm×108mm×79.9mm			

2-2. Terminals

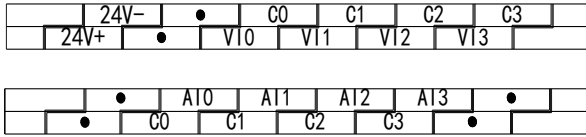

Channel	Terminal name	Signal name
CH0	V10	V10+ voltage input
	C0	V10- voltage input
CH1	V11	V11+ voltage input
	C1	V11- voltage input
CH2	V12	V12+ voltage input
	C2	V12- voltage input
CH3	V13	V13+ voltage input
	C3	V13- voltage input
CH4	AI0	AI0+ current input
	C0	AI0- current input
CH5	AI1	AI1+ current input
	C1	AI1- current input
CH6	AI2	AI2+ current input
	C2	AI2- current input
CH7	AI3	AI3+ current input
	C3	AI3- current input
-	24V+	+24V power supply
	24V-	Common terminal of power supply

2-3. I/O distribution

XD series analog expansion modules don't occupy I/O unit, the converted data is directly transferred to PLC register. Each channel address:

I/O address list

Register address of expansion module 1:

Channel	AD signal	Channel enable (set ON the enable bit to use this channel)

0CH	ID10000	Y10000
1CH	ID10001	Y10001
2CH	ID10002	Y10002
3CH	ID10003	Y10003
4CH	ID10004	Y10004
5CH	ID10005	Y10005
6CH	ID10006	Y10006
7CH	ID10007	Y10007

Register address of expansion module 2:

Channel	AD signal	Channel enable (set ON the enable bit to use this channel)
0CH	ID10100	Y10100
1CH	ID10101	Y10101
2CH	ID10102	Y10102
3CH	ID10103	Y10103
4CH	ID10104	Y10104
5CH	ID10105	Y10105
6CH	ID10106	Y10106
7CH	ID10107	Y10107

Register address of expansion module 3:

Channel	AD signal	Channel enable (set ON the enable bit to use this channel)
0CH	ID10200	Y10200
1CH	ID10201	Y10201
2CH	ID10202	Y10202
3CH	ID10203	Y10203
4CH	ID10204	Y10204
5CH	ID10205	Y10205
6CH	ID10206	Y10206
7CH	ID10207	Y10207

Register address of expansion module 4:

Channel	AD signal	Channel enable (set ON the enable bit to use this channel)
0CH	ID10300	Y10300
1CH	ID10301	Y10301
2CH	ID10302	Y10302
3CH	ID10303	Y10303
4CH	ID10304	Y10304
5CH	ID10305	Y10305
6CH	ID10306	Y10306
7CH	ID10307	Y10307

Register address of expansion module 5:

Channel	AD signal	Channel enable (set ON the enable bit to use this channel)
0CH	ID10400	Y10400
1CH	ID10401	Y10401
2CH	ID10402	Y10402
3CH	ID10403	Y10403
4CH	ID10404	Y10404
5CH	ID10405	Y10405
6CH	ID10406	Y10406
7CH	ID10407	Y10407

Register address of expansion module 6:

Channel	AD signal	Channel enable (set ON the enable bit to use this channel)
0CH	ID10500	Y10500
1CH	ID10501	Y10501
2CH	ID10502	Y10502
3CH	ID10503	Y10503
4CH	ID10504	Y10504
5CH	ID10505	Y10505
6CH	ID10506	Y10506
7CH	ID10507	Y10507

Register address of expansion module 7:

Channel	AD signal	Channel enable (set ON the enable bit to use this channel)
0CH	ID10600	Y10600
1CH	ID10601	Y10601
2CH	ID10602	Y10602
3CH	ID10603	Y10603
4CH	ID10604	Y10604
5CH	ID10605	Y10605
6CH	ID10606	Y10606
7CH	ID10607	Y10607

Register address of expansion module 8:

Channel	AD signal	Channel enable (set ON the enable bit to use this channel)
0CH	ID10700	Y10700
1CH	ID10701	Y10701
2CH	ID10702	Y10702
3CH	ID10703	Y10703
4CH	ID10704	Y10704
5CH	ID10705	Y10705
6CH	ID10706	Y10706
7CH	ID10707	Y10707

Register address of expansion module 9:

Channel	AD signal	Channel enable (set ON the enable bit to use this channel)
0CH	ID10800	Y11000
1CH	ID10801	Y11001
2CH	ID10802	Y11002
3CH	ID10803	Y11003
4CH	ID10804	Y11004
5CH	ID10805	Y11005
6CH	ID10806	Y11006
7CH	ID10807	Y11007

Register address of expansion module 10:

Channel	AD signal	Channel enable (set ON the enable bit to use this channel)
0CH	ID10900	Y11100
1CH	ID10901	Y11101
2CH	ID10902	Y11102
3CH	ID10903	Y11103
4CH	ID10904	Y11104
5CH	ID10905	Y11105
6CH	ID10906	Y11106
7CH	ID10907	Y11107

Register address of expansion module 11:

Channel	AD signal	Channel enable (set ON the enable bit to use this channel)
0CH	ID11000	Y11200
1CH	ID11001	Y11201
2CH	ID11002	Y11202
3CH	ID11003	Y11203
4CH	ID11004	Y11204
5CH	ID11005	Y11205
6CH	ID11006	Y11206
7CH	ID11007	Y11207

Register address of expansion module 12:

Channel	AD signal	Channel enable (set ON the enable bit to use this channel)
0CH	ID11100	Y11300
1CH	ID11101	Y11301
2CH	ID11102	Y11302
3CH	ID11103	Y11303
4CH	ID11104	Y11304
5CH	ID11105	Y11305
6CH	ID11106	Y11306

7CH	ID11107	Y11307
-----	---------	--------

Register address of expansion module 13:

Channel	AD signal	Channel enable (set ON the enable bit to use this channel)
0CH	ID11200	Y11400
1CH	ID11201	Y11401
2CH	ID11202	Y11402
3CH	ID11203	Y11403
4CH	ID11204	Y11404
5CH	ID11205	Y11405
6CH	ID11206	Y11406
7CH	ID11207	Y11407

Register address of expansion module 14:

Channel	AD signal	Channel enable (set ON the enable bit to use this channel)
0CH	ID11300	Y11500
1CH	ID11301	Y11501
2CH	ID11302	Y11502
3CH	ID11303	Y11503
4CH	ID11304	Y11504
5CH	ID11305	Y11505
6CH	ID11306	Y11506
7CH	ID11307	Y11507

Register address of expansion module 15:

Channel	AD signal	Channel enable (set ON the enable bit to use this channel)
0CH	ID11400	Y11600
1CH	ID11401	Y11601
2CH	ID11402	Y11602

3CH	ID11403	Y11603
4CH	ID11404	Y11604
5CH	ID11405	Y11605
6CH	ID11406	Y11606
7CH	ID11407	Y11607

Register address of expansion module 16:

Channel	AD signal	Channel enable (set ON the enable bit to use this channel)
0CH	ID11500	Y11700
1CH	ID11501	Y11701
2CH	ID11502	Y11702
3CH	ID11503	Y11703
4CH	ID11504	Y11704
5CH	ID11505	Y11705
6CH	ID11506	Y11706
7CH	ID11507	Y11707

Note:

1. Forbid the unused channel to improve the I/O scanning speed.
2. If set off the enable bit of the channel, this channel will not accept the data. (the data display is 0).

2-4. Working mode

There are two ways to set the working mode:

1. XDPpro software
2. Flash registers of PLC

XDPpro software:

Open the XDPpro software, click configure/expansion module settings:

Set the model and channel parameters in the following window. Then click write to PLC.

Please restart the PLC after setting.

Note: first-order low-pass filter will weighted present sampling value with last time filter output to get the final filter value. The filter factor range is 0 to 255, the default value is 0 which means no filter.

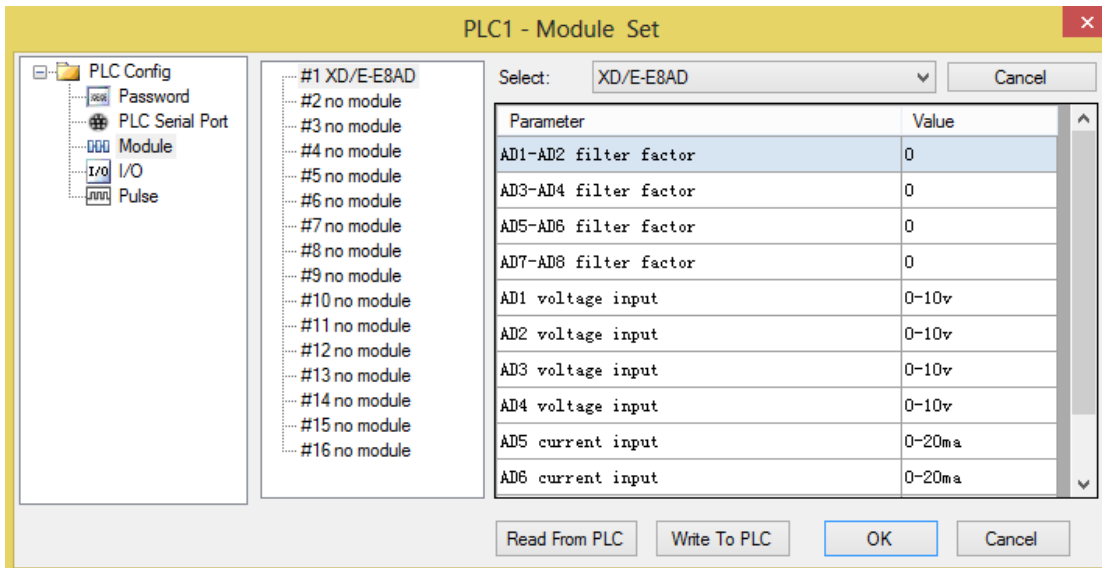

Flash registers:

0CH~3CH channels have two modes to select: voltage 0~5V or 0~10V, 4CH~7CH channels have two modes to select, current 0~20mA or 4~20mA. Set the modes through SFD registers of PLC. See the following table:

Module no.	SFD address	Module no.	SFD address
#1	SFD350~SFD359	#9	SFD430~SFD439
#2	SFD360~SFD369	#10	SFD440~SFD449
#3	SFD370~SFD379	#11	SFD450~SFD459
#4	SFD380~SFD389	#12	SFD460~SFD469
#5	SFD390~SFD399	#13	SFD470~SFD479
#6	SFD400~SFD409	#14	SFD480~SFD489
#7	SFD410~SFD419	#15	SFD490~SFD499
#8	SFD420~SFD429	#16	SFD500~SFD509

Note: each SFD register can set 4 channels mode. Each register has 16 bits, every 4 bits set one channel mode.

SFD bit definition:

BYTE0	Bit7	Bit6	Bit5	Bit4	Bit3	Bit2	Bit1	Bit0	Explanation
	AD channel 2, channel 1 filter time								AD filter time
BYTE1	AD channel 4, channel 3 filter time								
BYTE2	AD channel 6, channel 5 filter time								
BYTE3	AD channel 8, channel 7 filter time								
Byte4	Bit7	Bit6	Bit5	Bit4	Bit3	Bit2	Bit1	Bit0	To define the AD input range. Byte4 low 4 bits set channel 1 mode, high 4 bits set channel 2 mode. Byte5 low 4 bits set channel 3 mode, high 4 bits set channel 4 mode. Byte6 low 4 bits set channel 5 mode, high 4 bits set channel 6 mode. Byte7 low 4 bits set channel 7 mode, high 4 bits set channel 8 mode.
	AD2				AD1				
-	-	00: 0~10V 01: 0~5V 10: -10V~10V 11: -5V~5V		-	-	00: 0~10V 01: 0~5V 10: -10V~10V 11: -5V~5V			
Byte5	Bit7	Bit6	Bit5	Bit4	Bit3	Bit2	Bit1	Bit0	
	AD4				AD3				
-	-	00: 0~10V 01: 0~5V 10: -10V~10V 11: -5V~5V		-	-	00: 0~10V 01: 0~5V 10: -10V~10V 11: -5V~5V			
Byte6	Bit7	Bit6	Bit5	Bit4	Bit3	Bit2	Bit1	Bit0	
	AD6				AD5				
-	-	00: 0~20mA 01: 4~20mA 10: -20~20mA		-	-	00: 0~20mA 01: 4~20mA 10: -20~20mA			
Byte7	Bit7	Bit6	Bit5	Bit4	Bit3	Bit2	Bit1	Bit0	
	AD8				AD7				
-	-	00: 0~20mA 01: 4~20mA 10: -20~20mA		-	-	00: 0~20mA 01: 4~20mA 10: -20~20mA			
Byte8~ Byte19	-								

For example: set module no.1 channel 1 and channel 0 mode to 0~10V. Set channel 3 and channel 2 mode to 0~5V. Set channel 5 and channel 4 mode to 0~20mA. Set channel 7 and channel 6 mode to 4~20mA. The filter factor of channel 0 to channel 3 is 255. The filter factor of channel 4 to channel 7 is 100.

Then the SFD350=FFFFH SFD351=6464H SFD352=1100H SFD353=1100H

2-5. Exterior connection

Notes:

- When connect external +24V power, please use the 24V power of PLC to avoid interference.

- To avoid interference, please use shield cable and single point ground for the shield layer.

Voltage input:

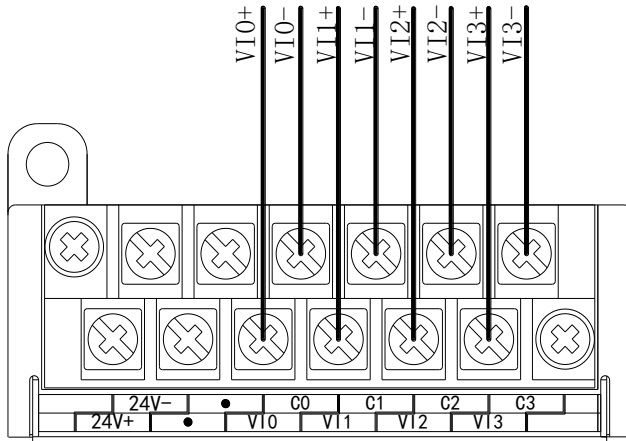

Current input:

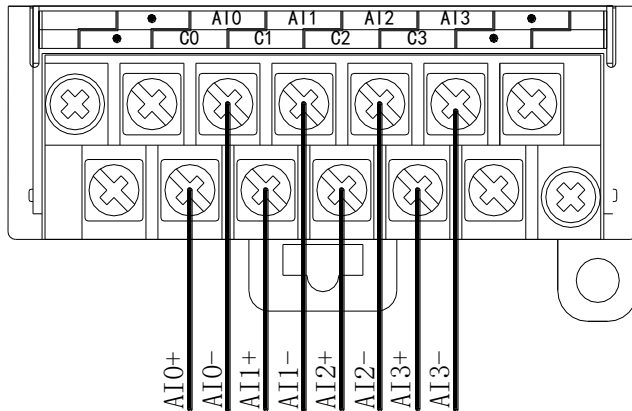

XD-E8AD current input wiring:

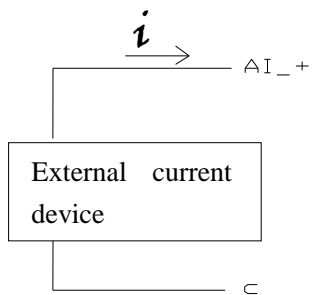

2-6. AD conversion diagram

The relationship between analog value and digital value is shown as the following diagram:

Channel 0 ~ Channel 3 voltage mode:

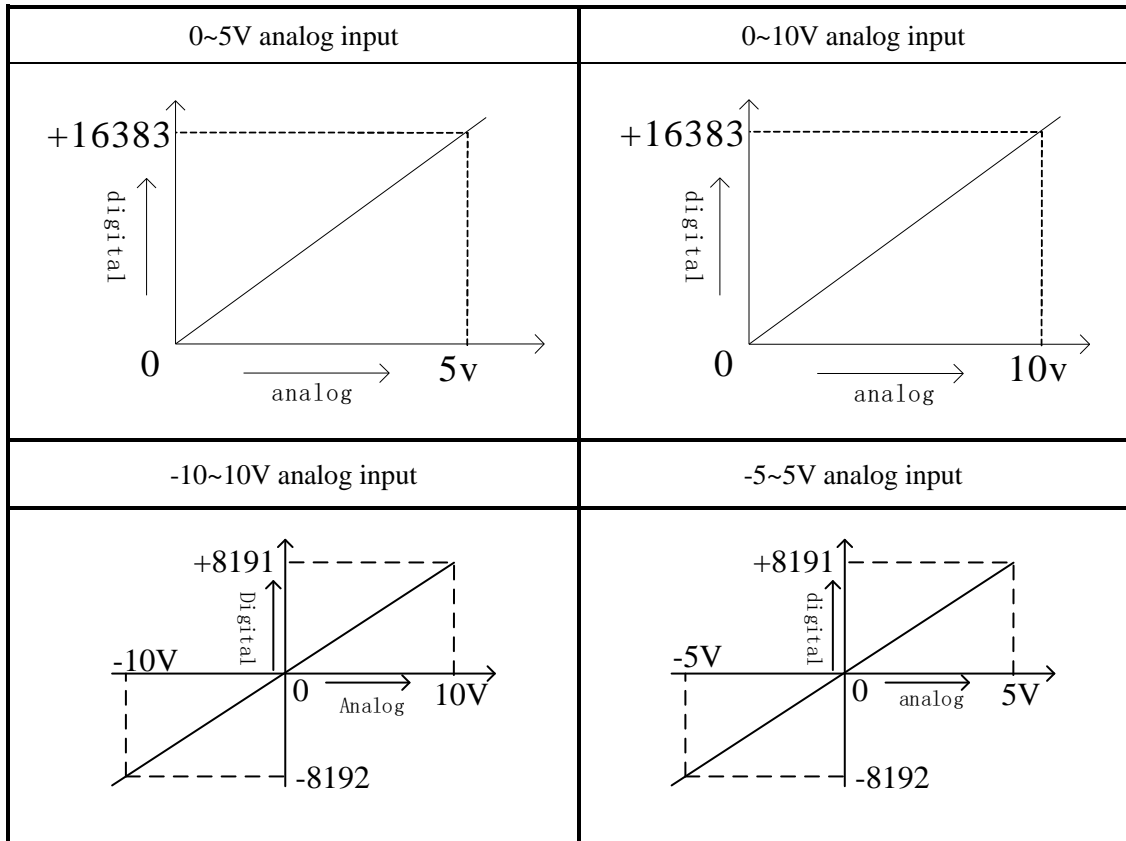

Channel 4 ~ Channel 7 current mode:

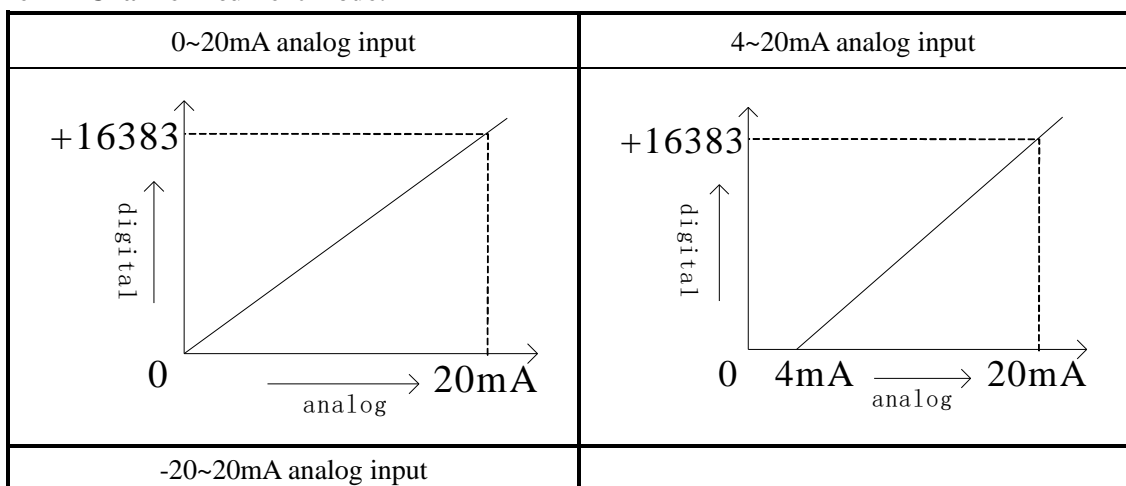

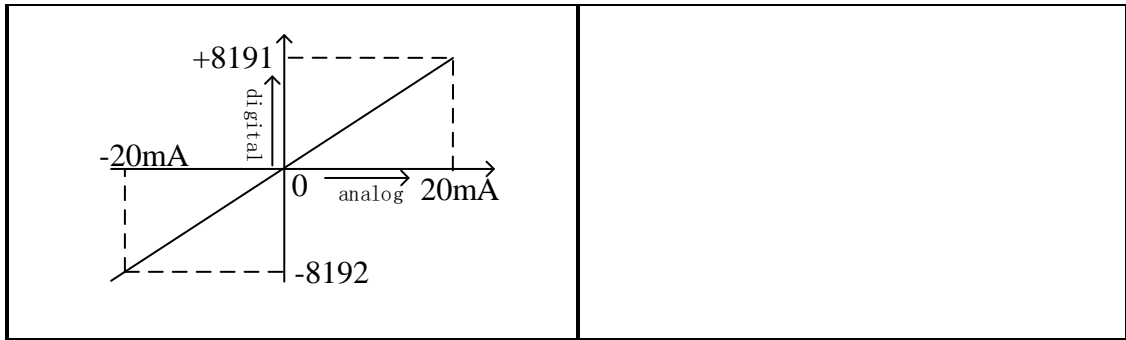

2-7. Program application

Real-time read the data of the 8 channels (module no.1)

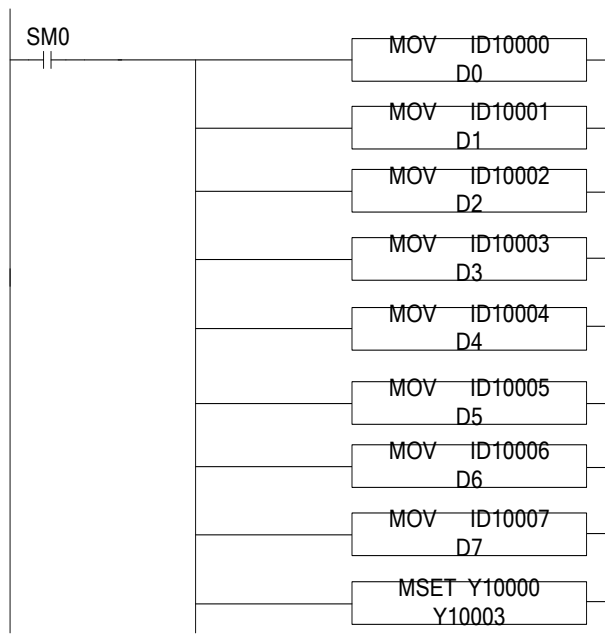

Explanation:

SM0 is always ON coil.

PLC is running. PLC keeps on writing channel 0 data to D0, channel 1 data to D1, channel 2 data to D2, channel 3 data to D3, channel 4 data to D4, channel 5 data to D5, channel 6 data to D6, channel 7 data to D7.

Set ON all the channels enable bits.

3. Analog input/output module XD-E4AD2DA

3-1. Specification

XD-E4AD2DA transform the 4 channels analog value to digital value, 2 channels digital value to analog value, and send them to PLC.

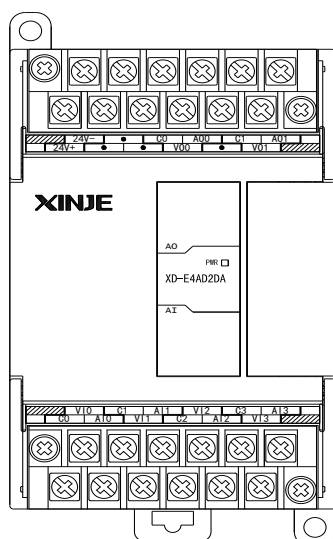

- 4 channels 14 bits analog input and 2 channels 12 bits analog output
- 4 channels selectable voltage 0~5V, 0~10V, current 0~20mA, 4~20mA input and 2 channels selectable voltage 0~5V, 0~10V, current 0~20mA, 4~20mA output.
- Up to 10 expansion modules can be connected to XD3.
- Up to 16 expansion modules can be connected to XDM.

Items	Analog input (AD)		Analog output (DA)	
	Voltage input	Current input	Voltage output	Current output
Analog input bound	0~5V, 0~10V	0~20mA, 4~20mA	-	
Max input bound	DC ±15V	0~40mA	-	
Analog output bound	-		0~5V, 0~10V (Exterior load resistance is less than 2KΩ~1MΩ)	0~20mA, 4~20mA (Exterior load resistance is less than 500Ω)
Digital input bound	-		12 bits binary data (0~4095)	
Digital output bound	14 bits binary data (0~16383)		-	
Distinguish ratio	1/16383(14Bit)		1/4095(12Bit)	
Integrate precision	1%			
Convert speed	2ms per channel		2ms per channel	
Power used by analog	DC24V ±10%, 150mA			
Install format	Fixed with M3 screws or directly installed on orbit of DIN46277 (Width: 35mm)			
Exterior size	63mm×108mm×79.9mm			

3-2. Terminals

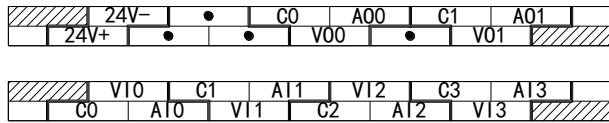

Channel	Terminal name	Signal name
CH0	AI0	Current input
	VI0	Voltage input
	C0	CH0 common terminal of analog input
CH1	AI1	Current input
	VI1	Voltage input
	C1	CH1 common terminal of analog input
CH2	AI2	Current input
	VI2	Voltage input
	C2	CH2 common terminal of analog input
CH3	AI3	Current input
	VI3	Voltage input
	C3	CH3 common terminal of analog input
CH0	AO0	Current output
	VO0	Voltage output
	C0	CH0 common terminal of analog output
CH1	AO1	Current output
	VO1	Voltage output
	C1	CH1 common terminal of analog output
-	24V+	+24V power supply
	24V-	Common terminal of power supply

3-3. The assignment of I/O address

XD series analog modules do not occupy I/O units; the converted data is directly transferred into PLC register,

Register address of module1:

Channel	AD signal	Channel enable bit (set ON the bit to use this channel)
0CH	ID10000	Y10000
1CH	ID10001	Y10001
2CH	ID10002	Y10002

3CH	ID10003	Y10003
Channel	DA signal	
0CH	QD10000	Y10004
1CH	QD10001	Y10005

Register address of module2:

Channel	AD signal	Channel enable bit (set ON the bit to use this channel)
0CH	ID10100	Y10100
1CH	ID10101	Y10101
2CH	ID10102	Y10102
3CH	ID10103	Y10103
Channel	DA signal	
0CH	QD10100	Y10104
1CH	QD10101	Y10105

Register address of module3:

Channel	AD signal	Channel enable bit (set ON the bit to use this channel)
0CH	ID10200	Y10200
1CH	ID10201	Y10201
2CH	ID10202	Y10202
3CH	ID10203	Y10203
Channel	DA signal	
0CH	QD10200	Y10204
1CH	QD10201	Y10205

Register address of module4:

Channel	AD signal	Channel enable bit (set ON the bit to use this channel)
0CH	ID10300	Y10300
1CH	ID10301	Y10301
2CH	ID10302	Y10302
3CH	ID10303	Y10303
Channel	DA signal	
0CH	QD10300	Y10304
1CH	QD10301	Y10305

Register address of module5:

Channel	AD signal	Channel enable bit (set ON the bit to use this channel)
0CH	ID10400	Y10400
1CH	ID10401	Y10401
2CH	ID10402	Y10402
3CH	ID10403	Y10403
Channel	DA signal	
0CH	QD10400	Y10404
1CH	QD10401	Y10405

Register address of module6:

Channel	AD signal	Channel enable bit (set ON the bit to use this channel)
0CH	ID10500	Y10500
1CH	ID10501	Y10501
2CH	ID10502	Y10502
3CH	ID10503	Y10503
Channel	DA signal	
0CH	QD10500	Y10504
1CH	QD10501	Y10505

Register address of module7:

Channel	AD signal	Channel enable bit (set ON the bit to use this channel)
0CH	ID10600	Y10600
1CH	ID10601	Y10601
2CH	ID10602	Y10602
3CH	ID10603	Y10603
Channel	DA signal	
0CH	QD10600	Y10604
1CH	QD10601	Y10605

Register address of module8:

Channel	AD signal	Channel enable bit (set ON the bit to use this channel)
0CH	ID10700	Y10700
1CH	ID10701	Y10701
2CH	ID10702	Y10702
3CH	ID10703	Y10703
Channel	DA signal	
0CH	QD10700	Y10704
1CH	QD10701	Y10705

Register address of module9:

Channel	AD signal	Channel enable bit (set ON the bit to use this channel)
0CH	ID10800	Y11000
1CH	ID10801	Y11001
2CH	ID10802	Y11002
3CH	ID10803	Y11003
Channel	DA signal	
0CH	QD10800	Y11004
1CH	QD10801	Y11005

Register address of module10:

Channel	AD signal	Channel enable bit (set ON the bit to use this channel)
0CH	ID10900	Y11100
1CH	ID10901	Y11101
2CH	ID10902	Y11102
3CH	ID10903	Y11103
Channel	DA signal	
0CH	QD10900	Y11104
1CH	QD10901	Y11105

Register address of module11:

Channel	AD signal	Channel enable bit (set ON the bit to use this channel)
0CH	ID11000	Y11200
1CH	ID11001	Y11201
2CH	ID11002	Y11202
3CH	ID11003	Y11203
Channel	DA signal	
0CH	QD11000	Y11204
1CH	QD11001	Y11205

Register address of module12:

Channel	AD signal	Channel enable bit (set ON the bit to use this channel)
0CH	ID11100	Y11300
1CH	ID11101	Y11301
2CH	ID11102	Y11302
3CH	ID11103	Y11303
Channel	DA signal	
0CH	QD11100	Y11304
1CH	QD11101	Y11305

Register address of module13:

Channel	AD signal	Channel enable bit (set ON the bit to use this channel)
0CH	ID11200	Y11400
1CH	ID11201	Y11401
2CH	ID11202	Y11402
3CH	ID11203	Y11403
Channel	DA signal	
0CH	QD11200	Y11404
1CH	QD11201	Y11405

Register address of module14:

Channel	AD signal	Channel enable bit (set ON the bit to use this channel)
0CH	ID11300	Y11500
1CH	ID11301	Y11501
2CH	ID11302	Y11502
3CH	ID11303	Y11503
Channel	DA signal	
0CH	QD11300	Y11504
1CH	QD11301	Y11505

Register address of module15:

Channel	AD signal	Channel enable bit (set ON the bit to use this channel)
0CH	ID11400	Y11600
1CH	ID11401	Y11601
2CH	ID11402	Y11602
3CH	ID11403	Y11603
Channel	DA signal	
0CH	QD11400	Y11604
1CH	QD11401	Y11605

Register address of module16:

Channel	AD signal	Channel enable bit (set ON the bit to use this channel)
0CH	ID11500	Y11700
1CH	ID11501	Y11701
2CH	ID11502	Y11702
3CH	ID11503	Y11703
Channel	DA signal	
0CH	QD11500	Y11704
1CH	QD11501	Y11705

Note:

1. Forbid the unused channel to improve the I/O scanning speed.
2. If set off the enable bit of the input channel, this channel will not accept the data. (the data display is 0).
3. If set off the enable bit of the output channel, this channel will keep the former data.

3-4. Working mode

There are two ways to set the working mode:

1. XDPpro software
2. Flash registers of PLC

XDPpro software:

Open the XDPpro software, click configure/expansion module settings.

Set the model and channel parameters in the following window. Then click write to PLC.

Please restart the PLC after setting.

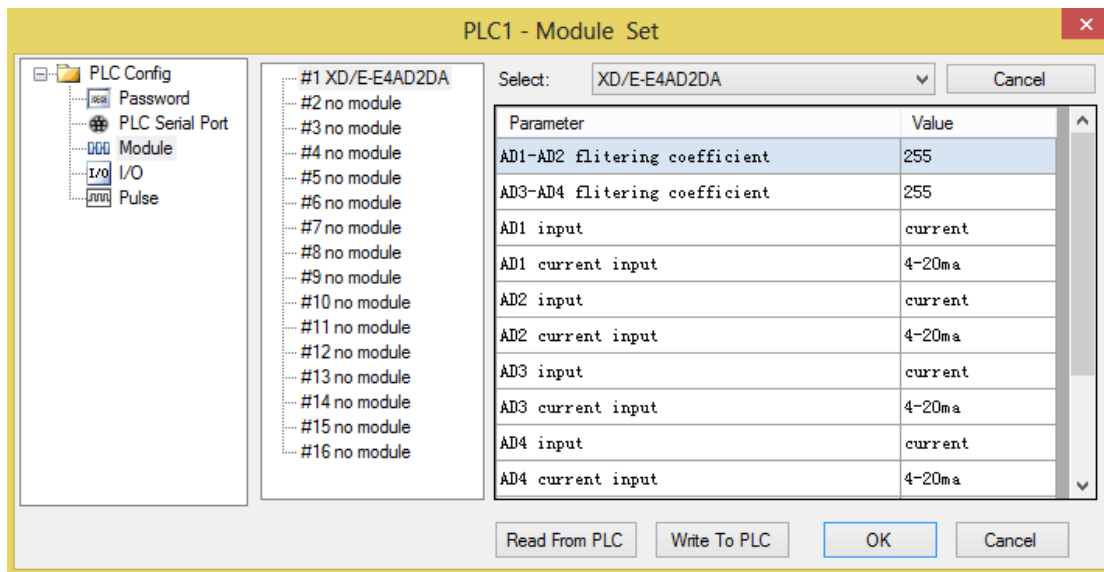

Note: first-order low-pass filter will weighted present sampling value with last time filter output to get the final filter value. The filter factor range is 0 to 255, the default value is 0 which means no filter.

Flash registers:

The module has current and voltage mode. Current has choices of 0~20mA, 4~20mA; voltage has choices of 0~5V, 0~10V. These parameters can be set through SFD registers.

Module no.	SFD address	Module no.	SFD address
#1	SFD350~SFD359	#9	SFD430~SFD439
#2	SFD360~SFD369	#10	SFD440~SFD449
#3	SFD370~SFD379	#11	SFD450~SFD459
#4	SFD380~SFD389	#12	SFD460~SFD469
#5	SFD390~SFD399	#13	SFD470~SFD479

#6	SFD400~SFD409	#14	SFD480~SFD489
#7	SFD410~SFD419	#15	SFD490~SFD499
#8	SFD420~SFD429	#16	SFD500~SFD509

Note: As shown in the preceding table, every register set 4 channels mode, each register has 16 bits, from low to high, every 4 bits set 1 channel mode.

SFD register bit definition:

Module no.1:

	Bit7	Bit6	Bit5	Bit4	Bit3	Bit2	Bit1	Bit0	Explanation
Byte0	AD channel 1, channel 2 filter time								AD filter time
Byte1	AD channel 3, channel 4 filter time								
Byte2	Bit7	Bit6	Bit5	Bit4	Bit3	Bit2	Bit1	Bit0	To define the AD and DA input range. Byte2 low 4 bits are AD channel 1, high 4 bits are AD channel 2. Byte3 low 4 bits are AD channel 3, high 4 bits are AD channel 4. Byte4 low 4 bits are DA channel 1, high 4 bits are DA channel 2.
	AD2				AD1				
-	-	0: voltage input 1: current input	0: 0~10V 1: 0~5V 0: 0~20mA 1: 4~20mA	-	-	0: voltage input 1: current input	0: 0~10V 1: 0~5V 0: 0~20mA 1: 4~20mA		
Byte3	Bit7	Bit6	Bit5	Bit4	Bit3	Bit2	Bit1	Bit0	
	AD4				AD3				
-	-	0: voltage input 1: current input	0: 0~10V 1: 0~5V 0: 0~20mA 1: 4~20mA	-	-	0: voltage input 1: current input	0: 0~10V 1: 0~5V 0: 0~20mA 1: 4~20mA		
Byte4	Bit7	Bit6	Bit5	Bit4	Bit3	Bit2	Bit1	Bit0	
	DA2				DA1				
-	-	0: voltage output 1: current output	0: 0~10V 1: 0~5V 0: 0~20mA 1: 4~20mA	-	-	0: voltage output 1: current output	0: 0~10V 1: 0~5V 0: 0~20mA 1: 4~20mA		
Byte5 ~ Byte19	-								

For example:

Set the module no.1 AD channel 3, 2, 1, 0 working mode to 0~20mA, 4~20mA, 0~10V, 0~5V. Set the channel 1 and 2 filter factor to 255, set the channel 3 and 4 filter factor to 100. Set DA channel 1 and 0 working mode to 0~10V, 0~20mA.

So the SFD register values are:

SFD350=FFH SFD351=64H SFD352=1H SFD353=23H SFD354=2H

3-5. Exterior connection

When make exterior connection, please read the following items:

- When connect +24V power, please choose 24V power of PLC to avoid interference.
- To avoid interference, please use shield cable and single point ground for the shield layer.

Voltage input

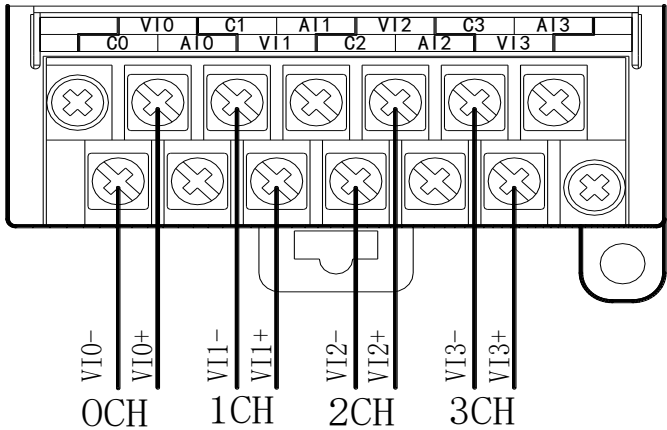

Voltage output

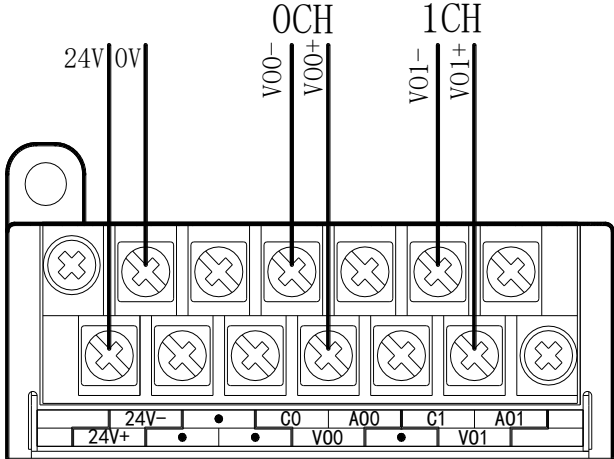

Current input

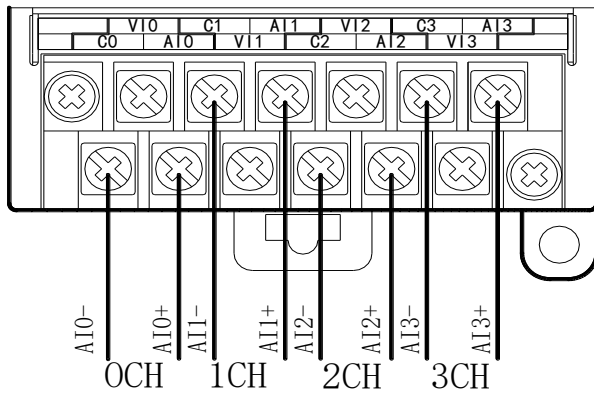

Current output

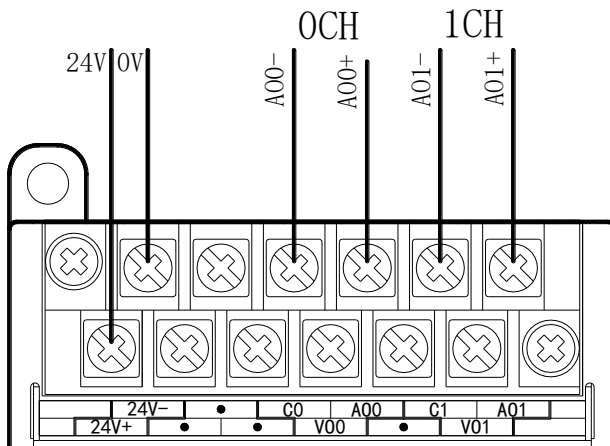

XD-E4AD2DA current output wiring:

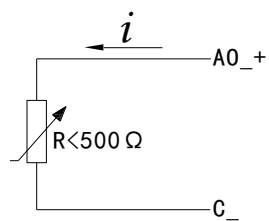

XD-E4AD2DA current input wiring:

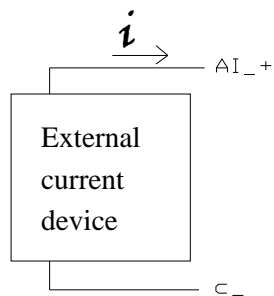

3-6. AD conversion diagram

The relationship between analog input and corresponding digital value:

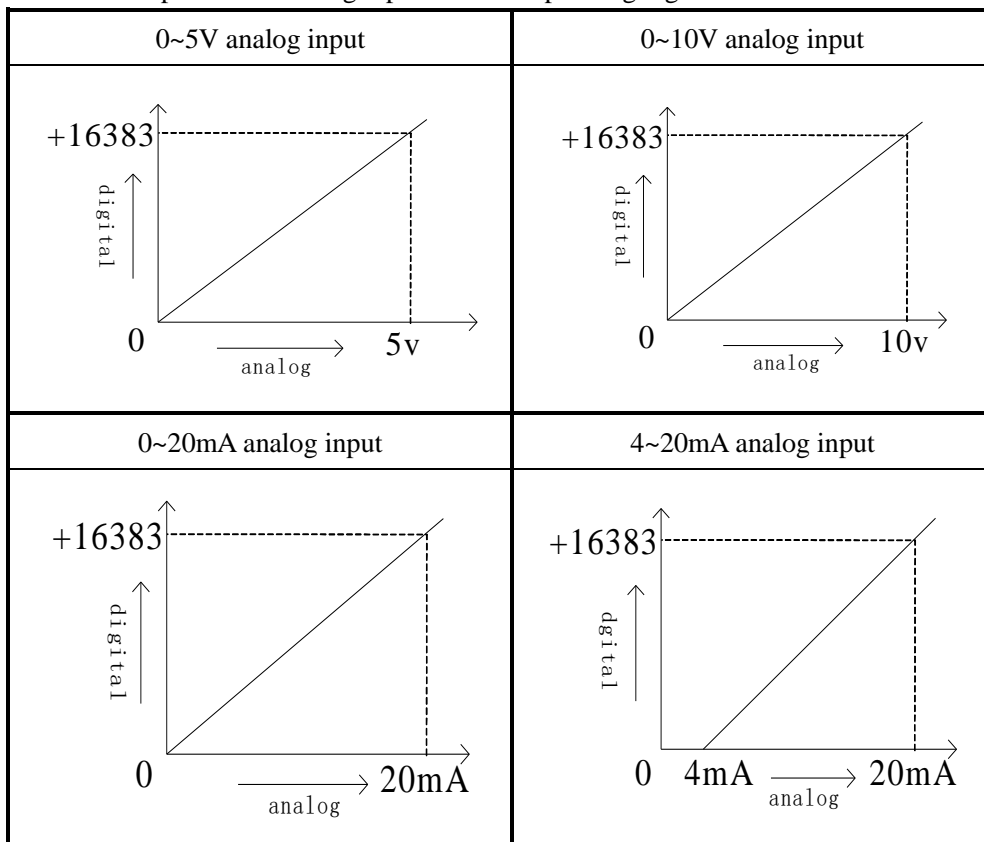

The relationship between input digital value and corresponding analog value:

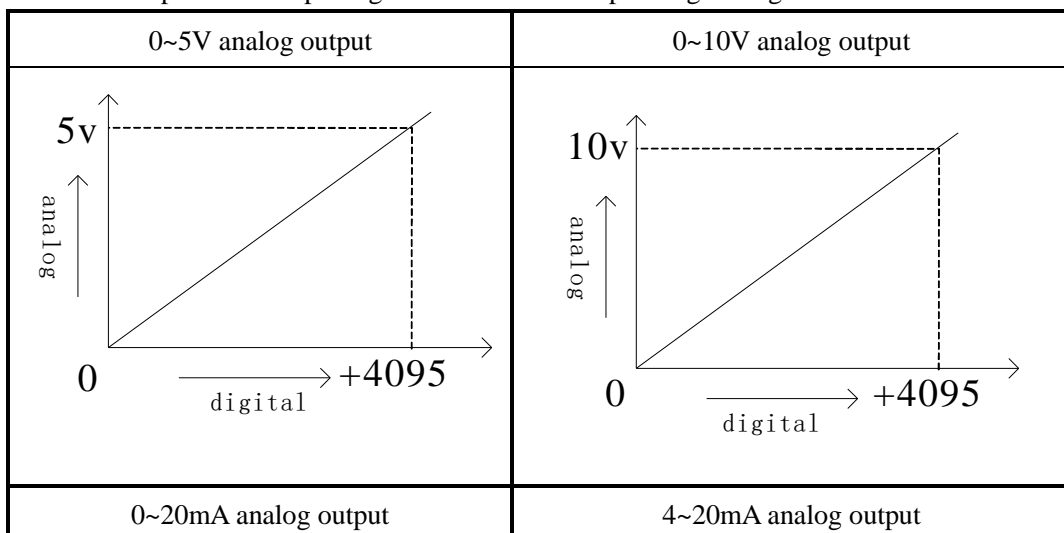

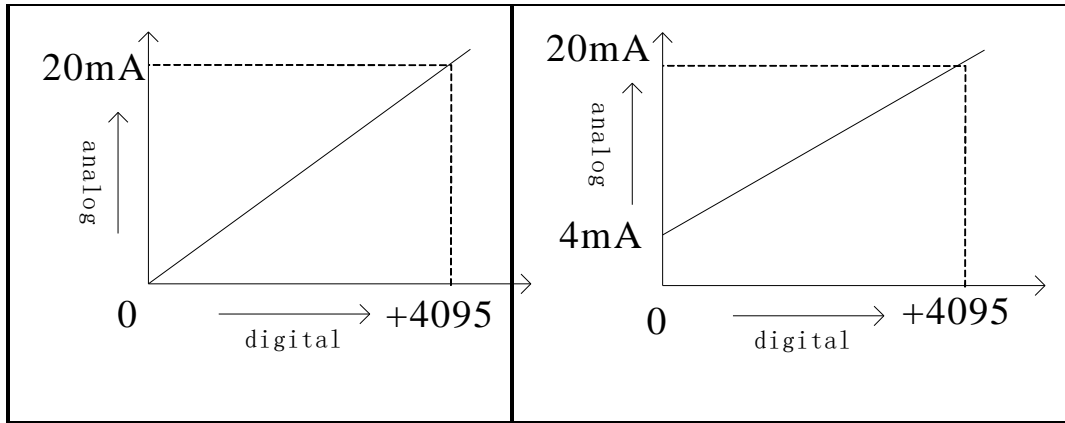

Note: When input data exceeds 4095, analog output will keep the max value of 5V, 10V or 20mA.

3-7. Programming

Example Real time read 4 channels data, write 2 channels data (take module no. 1 as an example)

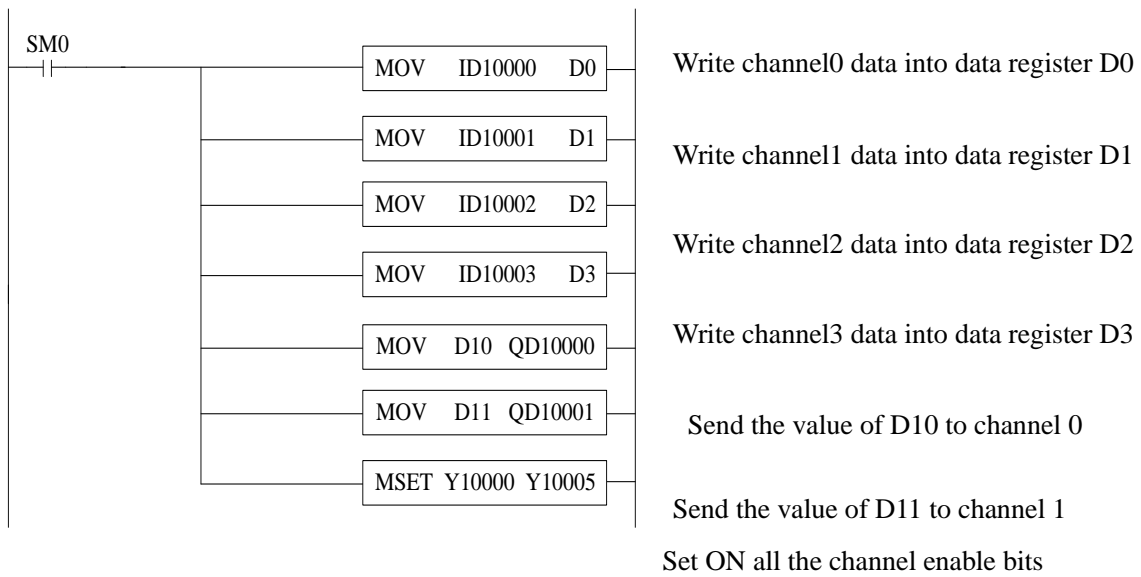

4. Analog Input Module XD-E4AD

4-1. Specifications

XD-E4AD transform the analog input (current or voltage) to digital value and send to PLC register.

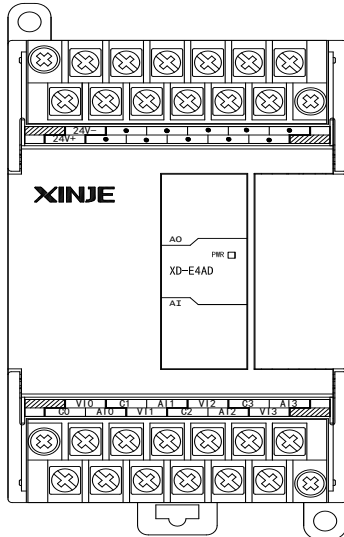

- 4 channels 14 bits analog input: voltage (0~5V, 0~10V), current (0~20mA, 4~20mA) for choice
- 14 bits high precision analog input
- up to 10 modules can be connected to the XD3 PLC
- up to 16 modules can be connected to the XDM PLC

ITEMS	Analog Input (AD)	
	Voltage Input	Current Input
Analog Input Range	0~5V, 0~10V	0~20mA, 4~20mA
Maximum Input Range	DC ±15V	0~40mA
Digital Output Range	14 bits binary (0~16383)	
Resolution	1/16383(14Bit)	
Synthesis Precision	1%	
Conversion Speed	2ms per channel	
Power Supply	DC24V ±10%,150mA	
Installation	Fix with M3 screw or install on DIN46277 gilder (Width: 35mm) directly	
Dimension	63mm×108mm×79.9mm	

4-2. Terminals

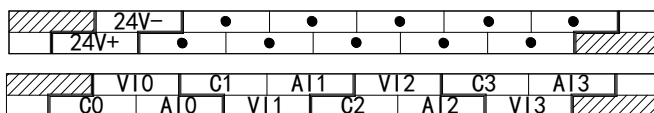

Channel	Terminal name	Signal name
CH0	AI0	Current input
	VI0	Voltage input
	C0	CH0 common terminal
CH1	AI1	Current input
	VI1	Voltage input
	C1	CH1 common terminal
CH2	AI2	Current input
	VI2	Voltage input
	C2	CH2 common terminal
CH3	AI3	Current input
	VI3	Voltage input
	C3	CH3 common terminal
-	24V+	+24V power supply
	24V-	Common terminal of power supply

4-3. I/O address assignment

XD series expansions do not occupy I/O units; the converted value is sent to PLC register directly.

Expansion module 1 address

Channel	AD signal	Channel enable bit (set ON the enable bit to use this channel)
0CH	ID10000	Y10000
1CH	ID10001	Y10001
2CH	ID10002	Y10002
3CH	ID10003	Y10003

Expansion module 2 address

Channel	AD signal	Channel enable bit (set ON the enable bit to use this channel)
0CH	ID10100	Y10100

1CH	ID10101	Y10101
2CH	ID10102	Y10102
3CH	ID10103	Y10103

Expansion module 3 address

Channel	AD signal	Channel enable bit (set ON the enable bit to use this channel)
0CH	ID10200	Y10200
1CH	ID10201	Y10201
2CH	ID10202	Y10202
3CH	ID10203	Y10203

Expansion module 4 address

Channel	AD signal	Channel enable bit (set ON the enable bit to use this channel)
0CH	ID10300	Y10300
1CH	ID10301	Y10301
2CH	ID10302	Y10302
3CH	ID10303	Y10303

Expansion module 5 address

Channel	AD signal	Channel enable bit (set ON the enable bit to use this channel)
0CH	ID10400	Y10400
1CH	ID10401	Y10401
2CH	ID10402	Y10402
3CH	ID10403	Y10403

Expansion module 6 address

Channel	AD signal	Channel enable bit (set ON the enable bit to use this channel)
0CH	ID10500	Y10500
1CH	ID10501	Y10501
2CH	ID10502	Y10502
3CH	ID10503	Y10503

Expansion module 7 address

Channel	AD signal	Channel enable bit (set ON the enable bit to use this channel)
0CH	ID10600	Y10600
1CH	ID10601	Y10601
2CH	ID10602	Y10602
3CH	ID10603	Y10603

Expansion module 8 address

Channel	AD signal	Channel enable bit (set ON the enable bit to use this channel)
0CH	ID10700	Y10700
1CH	ID10701	Y10701
2CH	ID10702	Y10702
3CH	ID10703	Y10703

Expansion module 9 address

Channel	AD signal	Channel enable bit (set ON the enable bit to use this channel)
0CH	ID10800	Y11000
1CH	ID10801	Y11001
2CH	ID10802	Y11002
3CH	ID10803	Y11003

Expansion module 10 address

Channel	AD signal	Channel enable bit (set ON the enable bit to use this channel)
0CH	ID10900	Y11100
1CH	ID10901	Y11101
2CH	ID10902	Y11102
3CH	ID10903	Y11103

Expansion module 11 address

Channel	AD signal	Channel enable bit (set ON the enable bit to use this channel)
0CH	ID11000	Y11200
1CH	ID11001	Y11201
2CH	ID11002	Y11202
3CH	ID11003	Y11203

Expansion module 12 address

Channel	AD signal	Channel enable bit (set ON the enable bit to use this channel)
0CH	ID11100	Y11300
1CH	ID11101	Y11301
2CH	ID11102	Y11302
3CH	ID11103	Y11303

Expansion module 13 address

Channel	AD signal	Channel enable bit (set ON the enable bit to use this channel)
0CH	ID11200	Y11400
1CH	ID11201	Y11401
2CH	ID11202	Y11402
3CH	ID11203	Y11403

Expansion module 14 address

Channel	AD signal	Channel enable bit (set ON the enable bit to use this channel)
0CH	ID11300	Y11500
1CH	ID11301	Y11501
2CH	ID11302	Y11502
3CH	ID11303	Y11503

Expansion module 15 address

Channel	AD signal	Channel enable bit (set ON the enable bit to use this channel)
0CH	ID11400	Y11600
1CH	ID11401	Y11601
2CH	ID11402	Y11602
3CH	ID11403	Y11603

Expansion module 16 address

Channel	AD signal	Channel enable bit (set ON the enable bit to use this channel)
0CH	ID11500	Y11700
1CH	ID11501	Y11701
2CH	ID11502	Y11702
3CH	ID11503	Y11703

Note:

1. Forbid the unused channel to improve the I/O scanning speed.
2. If set off the enable bit of the input channel, this channel will not accept the data. (the data display is 0).

4-4. Working mode

There are two ways to set the working mode:

1. XDPpro software
2. Flash registers of PLC

XDPpro software:

Open the XDPpro software, click configure/expansion module settings:

Set the model and channel parameters in the following window. Then click write to PLC.

Please restart the PLC after setting.

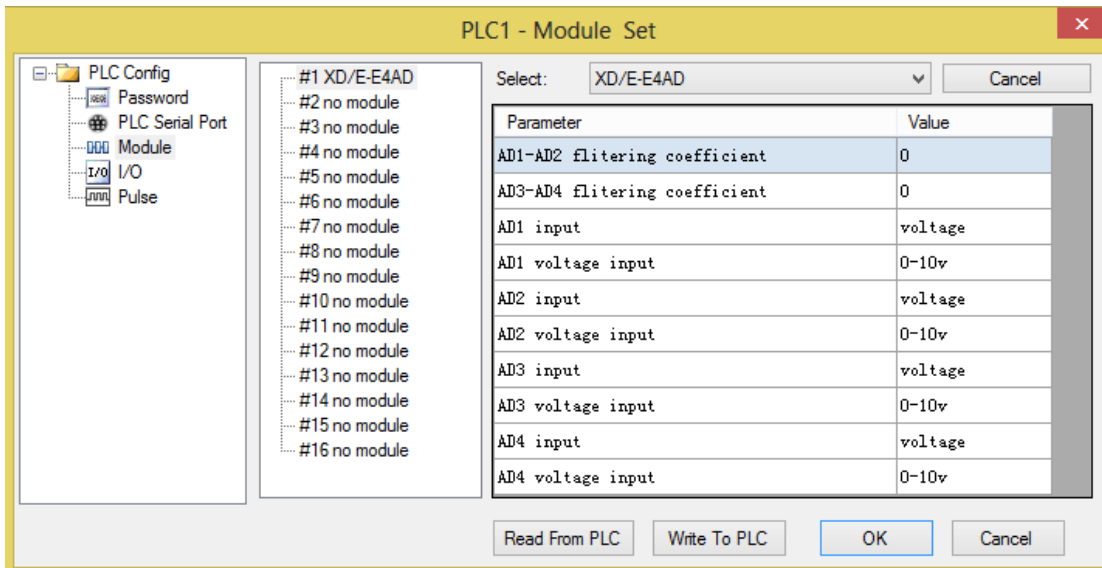

Note: first-order low-pass filter will weighted present sampling value with last time filter output to get the final filter value. The filter factor range is 0 to 255, the default value is 0 which means no filter.

Flash registers:

The working mode can be voltage 0~5V, 0~10V or current 0~20mA, 4~20mA, set through SFD registers of PLC:

Module no.	SFD address	Module no.	SFD address
#1	SFD350~SFD359	#9	SFD430~SFD439
#2	SFD360~SFD369	#10	SFD440~SFD449
#3	SFD370~SFD379	#11	SFD450~SFD459
#4	SFD380~SFD389	#12	SFD460~SFD469
#5	SFD390~SFD399	#13	SFD470~SFD479
#6	SFD400~SFD409	#14	SFD480~SFD489
#7	SFD410~SFD419	#15	SFD490~SFD499
#8	SFD420~SFD429	#16	SFD500~SFD509

Note: As shown in the preceding table, every register set 4 channels mode, each register has 16 bits, from low to high, and every 4 bits set 1 channel mode.

We take module 1 as an example to show how to set:

Byte0	Bit7	Bit6	Bit5	Bit4	Bit3	Bit2	Bit1	Bit0	Explanation
	AD channel 1, channel 2 filter time								AD filter time
Byte1	AD channel 3, channel 4 filter time								
Byte2	Bit7	Bit6	Bit5	Bit4	Bit3	Bit2	Bit1	Bit0	To define the AD input range. Byte2 low 4 bits are AD channel 1, high 4 bits are AD channel 2.
	AD2				AD1				
	-	-	0: voltage input 1: current input	0: 0~10V 1: 0~5V 0: 0~20mA 1: 4~20mA	-	-	0: voltage input 1: current input	0: 0~10V 1: 0~5V 0: 0~20mA 1: 4~20mA	Byte2 low 4 bits are AD channel 1, high 4 bits are AD channel 2. Byte3 low 4 bits are AD channel 3, high 4 bits are AD channel 4.
Byte3	Bit7	Bit6	Bit5	Bit4	Bit3	Bit2	Bit1	Bit0	
	AD4				AD3				
	-	-	0: voltage input 1: current input	0: 0~10V 1: 0~5V 0: 0~20mA 1: 4~20mA	-	-	0: voltage input 1: current input	0: 0~10V 1: 0~5V 0: 0~20mA 1: 4~20mA	
Byte4 ~ Byte19	-								

For example:

Set module no. 1 channel 3, 2, 1, 0 working mode to 0~20mA, 4~20mA, 0~10V, 0~5V. Set channel 1 and channel 2 filter factor to 255, set channel 3 and channel 4 filter factor to 100.

So the SFD values are:

SFD350=64FFH SFD351=2301H SFD352=0000H SFD353=0000H

4-5. Exterior connection

When make external connection, please note the following items:

- When connect external 24V power, please choose 24V power of PLC to avoid interference.
- To avoid interference, please use shield cable and single-point ground with the shield layer.

Voltage input

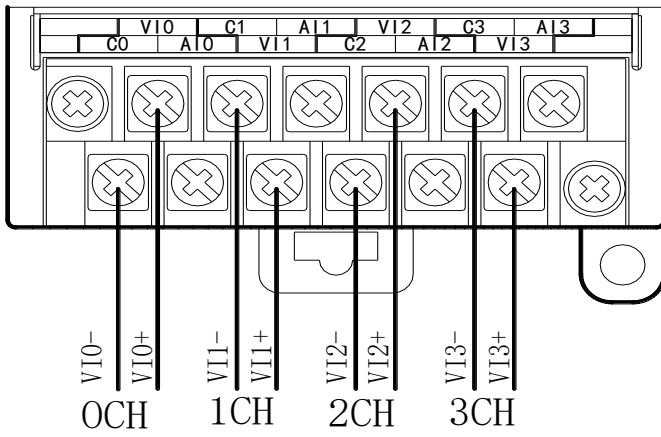

Current input

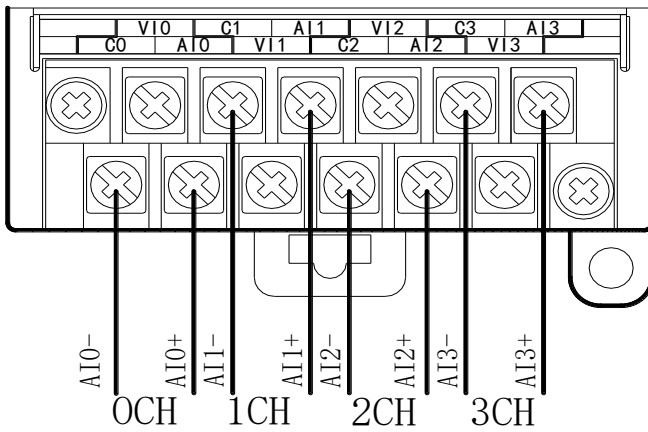

XD-E4AD current input wiring:

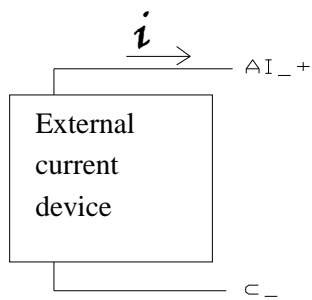

4-6. AD conversion diagram

The relationship between analog input and converted digital value is shown in the following chart:

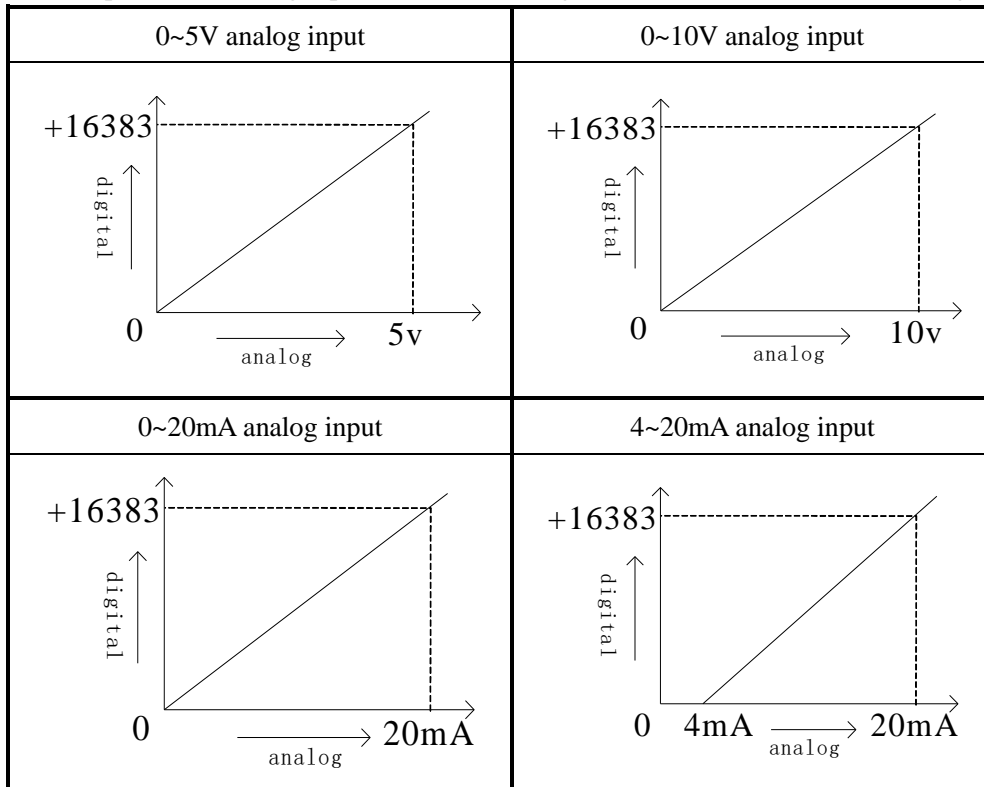

4-7. Programming

Example Real-time read the 4 channels data (take expansion 1 as an example)

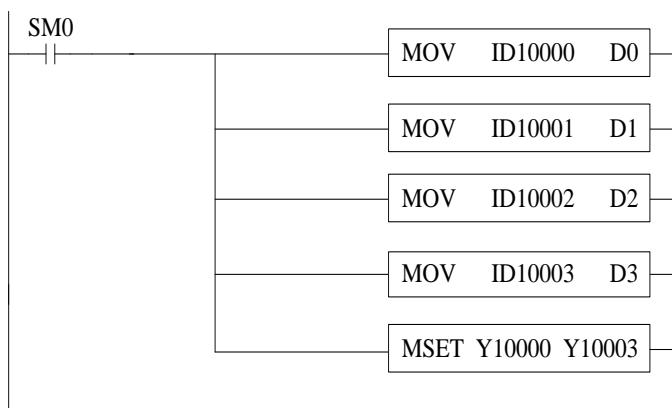

Explanation:

SM0 is always ON coil, it is ON when PLC is running.

Send channel 0 data to PLC register D0,

Send channel 1 data to PLC register D1,

Send channel 2 data to PLC register D2,
 Send channel 3 data to PLC register D3.
 Set ON all the channel enable bits.

5. Analog output module XD-E2DA

5-1. Specifications

XD-E2DA transform 12 bits digital value to current or voltage output.

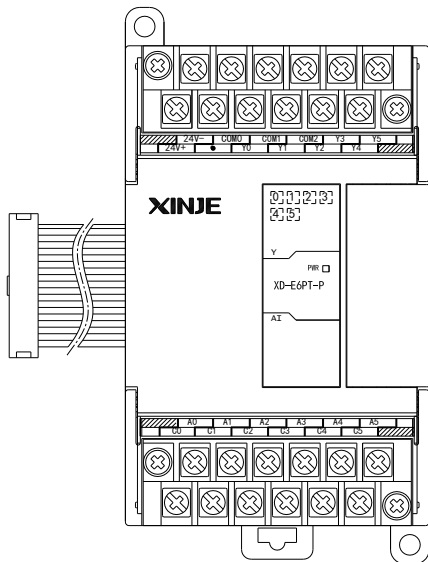

- 12 bits high precision analog output
- 2 channels voltage (0~5V/0~10V), current (0~20mA/4~20 mA) output for choice.
- Up to 10 modules can be connected to the XD3 PLC
- Up to 16 modules can be connected to XDM PLC

Items	Voltage output	Current output
Analog output	DC 0 to 5V, 0 to 10V (external load resistor 2KΩ~1MΩ)	DC 0 to 20mA, 4 to 20mA (external load resistor is less than 500Ω)
Digital input	12 bits binary value (0~4095)	
Resolution	1/4095(12 bit)	
General precision	1%	
Conversion speed	2ms per channel	
Power supply for analog using	DC24V ±10%,150mA	
Installation	Fix with M3 screws or install on DIN46277 (width: 35) leader directly	
Dimension	63mm×108mm×79.9mm	

5-2. Terminals

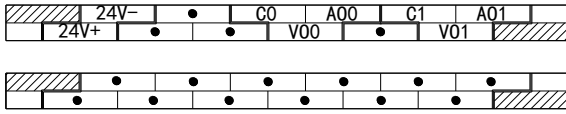

Channel	Terminal name	Signal name
CH0	A00	Current output
	V00	Voltage output
	C0	CH0 common terminal
CH1	A01	Current output
	V01	Voltage output
	C1	CH1 common terminal
-	24V+	+24V power supply
	24V-	Common terminal of power supply

5-3. I/O address assignment

XD series analog modules don't occupy I/O units, the converted value is sent to PLC register directly. The PLC registers are shown as the following:

Expansion module no.1

Channel	DA signal	Channel enable bit (set on this bit to use this channel)
0CH	QD10000	Y10000
1CH	QD10001	Y10001

Expansion module no.2

Channel	DA signal	Channel enable bit (set on this bit to use this channel)
0CH	QD10100	Y10100
1CH	QD10101	Y10101

Expansion module no.3

Channel	DA signal	Channel enable bit (set on this bit to use this channel)
0CH	QD10200	Y10200
1CH	QD10201	Y10201

Expansion module no.4

Channel	DA signal	Channel enable bit (set on this bit to use this channel)
0CH	QD10300	Y10300
1CH	QD10301	Y10301

Expansion module no.5

Channel	DA signal	Channel enable bit (set on this bit to use this channel)
0CH	QD10400	Y10400
1CH	QD10401	Y10401

Expansion module no.6

Channel	DA signal	Channel enable bit (set on this bit to use this channel)
0CH	QD10500	Y10500
1CH	QD10501	Y10501

Expansion module no.7

Channel	DA signal	Channel enable bit (set on this bit to use this channel)
0CH	QD10600	Y10600
1CH	QD10601	Y10601

Expansion module no.8

Channel	DA signal	Channel enable bit (set on this bit to use this channel)
0CH	QD10700	Y10700
1CH	QD10701	Y10701

Expansion module no.9

Channel	DA signal	Channel enable bit (set on this bit to use this channel)
0CH	QD10800	Y11000
1CH	QD10801	Y11001

Expansion module no.10

Channel	DA signal	Channel enable bit (set on this bit to use this channel)
0CH	QD10900	Y11100
1CH	QD10901	Y11101

Expansion module no.11

Channel	DA signal	Channel enable bit (set on this bit to use this channel)
0CH	QD11000	Y11200
1CH	QD11001	Y11201

Expansion module no.12

Channel	DA signal	Channel enable bit (set on this bit to use this channel)
0CH	QD11100	Y11300
1CH	QD11101	Y11301

Expansion module no.13

Channel	DA signal	Channel enable bit (set on this bit to use this channel)
0CH	QD11200	Y11400
1CH	QD11201	Y11401

Expansion module no.14

Channel	DA signal	Channel enable bit (set on this bit to use this channel)
0CH	QD11300	Y11500
1CH	QD11301	Y11501

Expansion module no.15

Channel	DA signal	Channel enable bit (set on this bit to use this channel)
0CH	QD11400	Y11600
1CH	QD11401	Y11601

Expansion module no.16

Channel	DA signal	Channel enable bit (set on this bit to use this channel)
0CH	QD11500	Y11700
1CH	QD11501	Y11701

Note:

1. Forbid the unused channel to improve the I/O scanning speed.
2. If set off the enable bit of the output channel, this channel will keep the present value.

5-4. Working mode

There are two ways to set the working mode:

1. XDPpro software
2. Flash registers of PLC

XDPpro software:

Open the XDPpro software, click configure/expansion module settings:

Set the model and channel parameters in the following window. Then click write to PLC.

Please restart the PLC after setting.

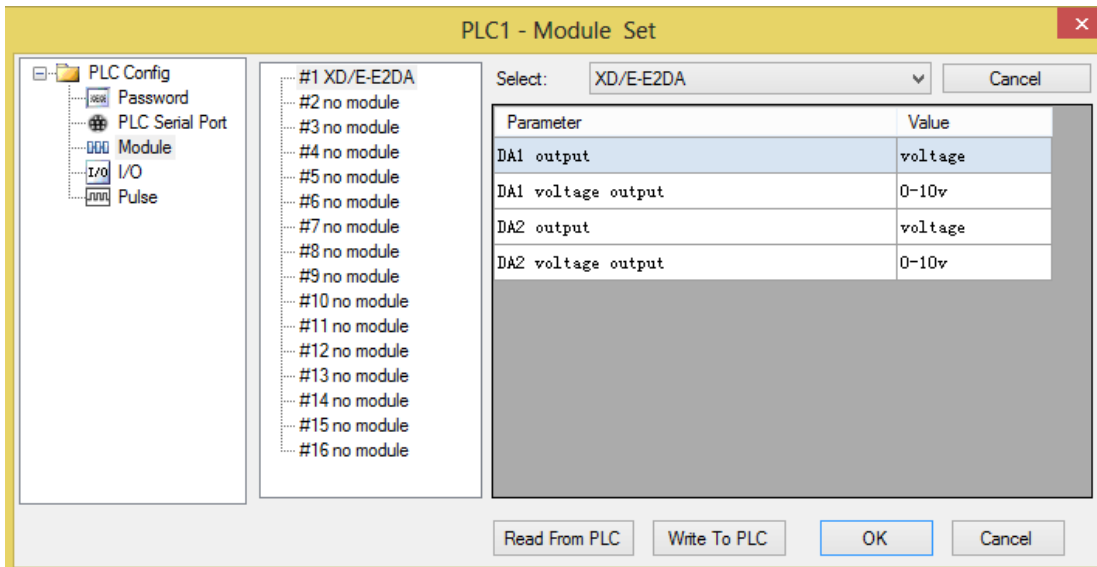

Note: first-order low-pass filter will weighted present sampling value with last time filter output to get the final filter value. The filter factor range is 0 to 255, the default value is 0 which means no filter.

Flash registers:

The module output has voltage 0 ~ 5V, 0 ~ 10V, current 0 ~ 20mA, 4 ~ 20mA, set the modes through the PLC FLASH registers SFD.

Module no.	SFD address	Module no.	SFD address
#1	SFD350~SFD359	#9	SFD430~SFD439
#2	SFD360~SFD369	#10	SFD440~SFD449
#3	SFD370~SFD379	#11	SFD450~SFD459
#4	SFD380~SFD389	#12	SFD460~SFD469
#5	SFD390~SFD399	#13	SFD470~SFD479
#6	SFD400~SFD409	#14	SFD480~SFD489
#7	SFD410~SFD419	#15	SFD490~SFD499
#8	SFD420~SFD429	#16	SFD500~SFD509

SFD bit definition:

Expansion module no.1:

	Bit7	Bit6	Bit5	Bit4	Bit3	Bit2	Bit1	Bit0	Explanation
	DA2				DA1				To define the DA output range. Byte0 low 4 bits are DA channel 1, high 4 bits are DA channel 2.
Byte0	-	-	0: voltage output 1: current output	0 : 0~10V 1: 0~5V 0 : 0~20mA 1 : 4~20mA	-	-	0: voltage output 1: current output	0:0~10V 1:0~5V 0:0~20mA 1:4~20mA	
Byte1 ~ Byte19	-								

For example:

Set channel 1 and channel 0 working mode to 0~10V, 0~20mA.

The SFD values are: SFD350=2H.

5-5. External connection

When make external connection, please note the following items:

- When connect to external +24V power supply, please use 24V power supply of PLC to avoid interference.
- To avoid interference, please use shield cable, and single-point ground with the shield layer.

Voltage output:

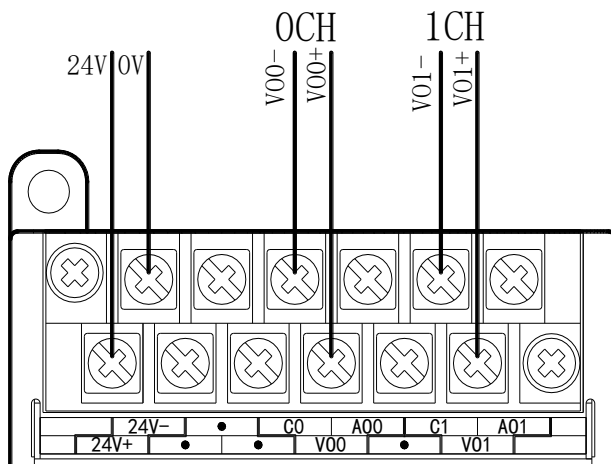

Current output:

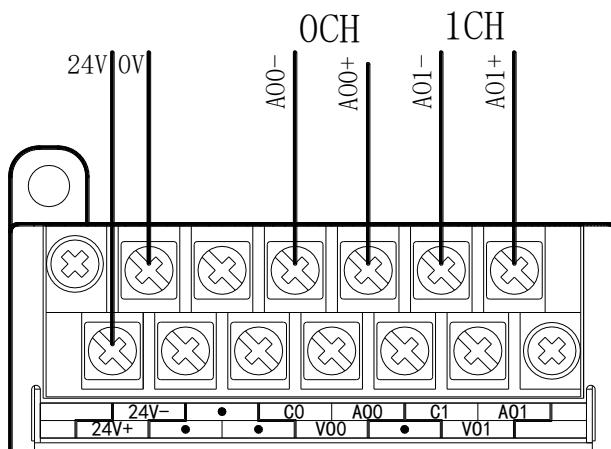

XD-E2DA current output wiring:

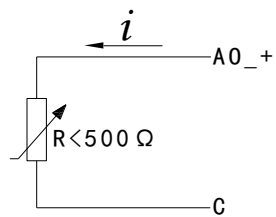

5-6. DA conversion diagram

The relationship between digital input value and analog output value is shown as below:

When the input value is larger than 4095, D/A converted analog value will remain 5V, 10V or 20mA.

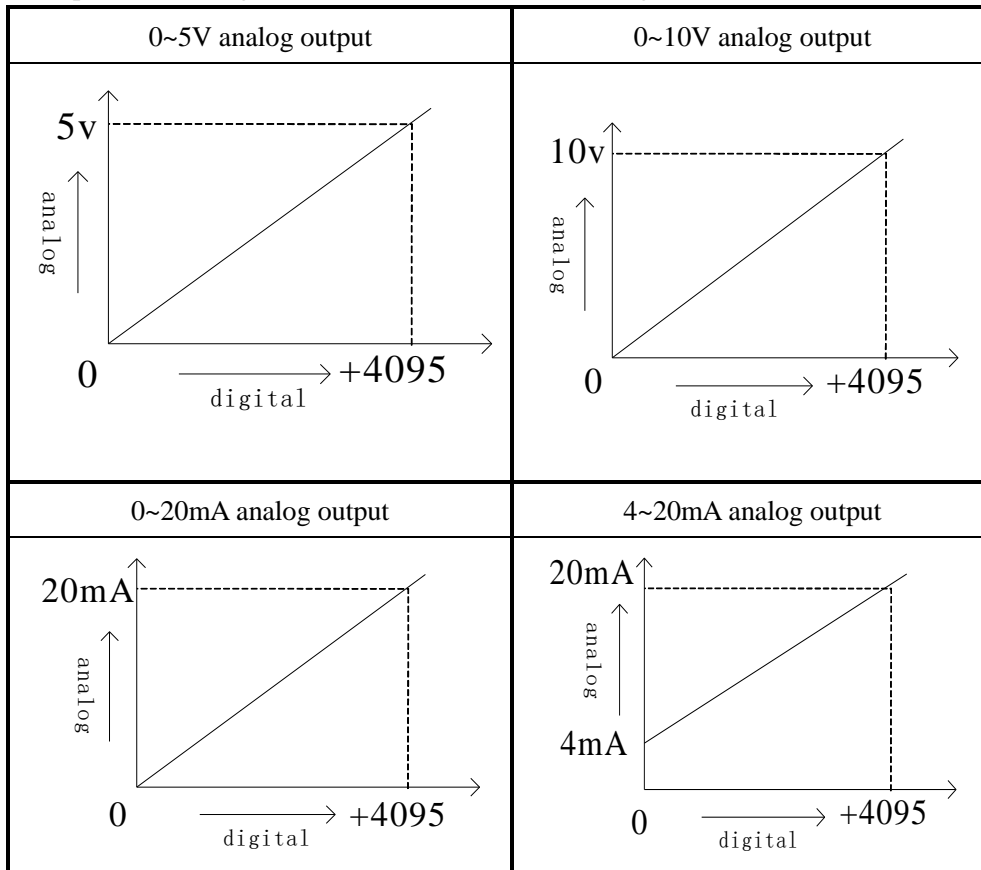

5-7. Programming

Real-time write data to 2 channels (take expansion module no.1 as an example)

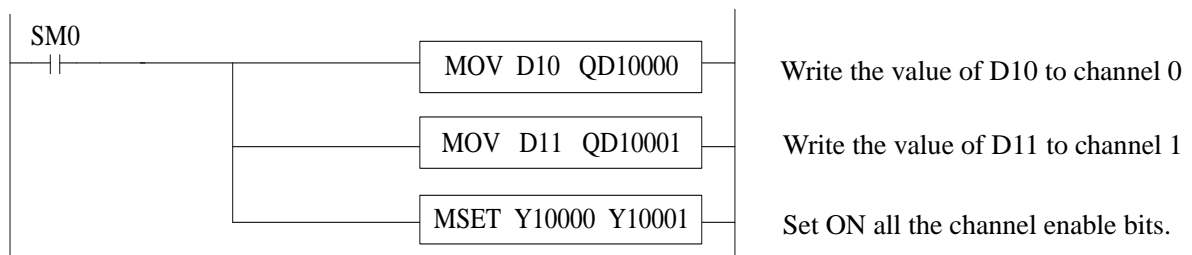

6. 1 channel pressure module XD-E1WT-A

6-1. Features

XD-E1WT-A is the expansion module of XD series PLC. It can test the voltage in the range of 0mV~39.06mV or the voltage signal from pressure sensor. Then it can transform the voltage to digital value through A/D transformation and do calculation.

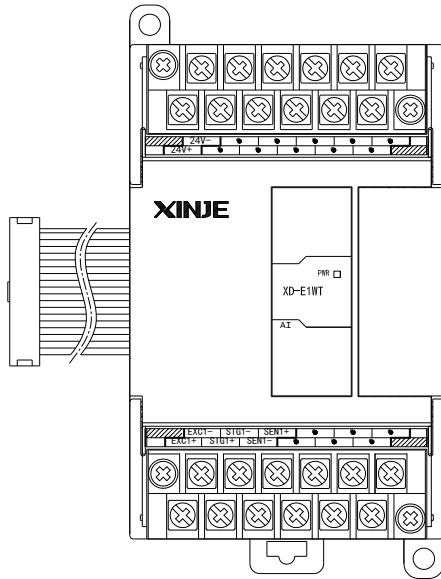

- 1 channels pressure sensor voltage signal input
- Test voltage signal in the range of 0~39.06mV
- 24-bit A/D transformation
- XD3 series PLC can connect 10 XD-E1WT-A modules
- XDM series PLC can connect 16 XD-E1WT-A modules

Input range	DC 0~39.06mV
Resolution	1/8388608 (24Bit)
Integrated precision	0.1%
Transformation speed	0-250 times/second
Power supply	DC24V ±10%, 100mA
Sensor power supply	5VDC/120mA, can parallel 4 pieces of 350Ω pressure sensor
Installation	Mount on DIN46277 rail (width 35mm) or fix with screw M3
Dimension	63mm×108mm×79.9mm
Working environment	No corrosive gas
Ambient temperature	0°C~60°C
Humidity	5~95%
Software version	V3.2 and higher version

6-2. Terminals

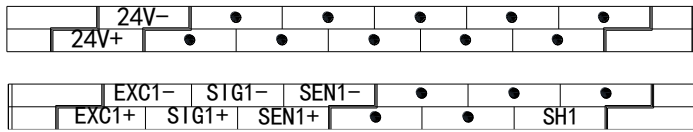

Channel	Terminal	Signal	Meaning
CH1	EXC1+	Pressure sensor power supply +	Connect to sensor power supply input
	EXC1-	Pressure sensor power supply -	
	SIG1+	Signal input +	Connect to sensor signal output
	SIG1-	Signal input -	
	SEN1+	Feedback voltage +	Power supply voltage feedback signal
	SEN1-	Feedback voltage -	
	SH1	Shield cable	
	24V+	+24V power supply	Module power supply
	24V-	Common terminal	

6-3. External connection

Notes:

1. Please use the 24V power supply on the PLC to avoid interference.
2. Please use shield cable and single-point ground.

Power supply wiring:

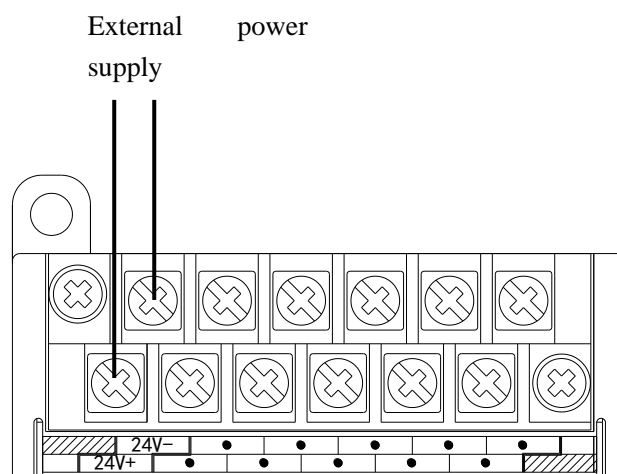

Connect to the pressure sensor:

6 wires mode:

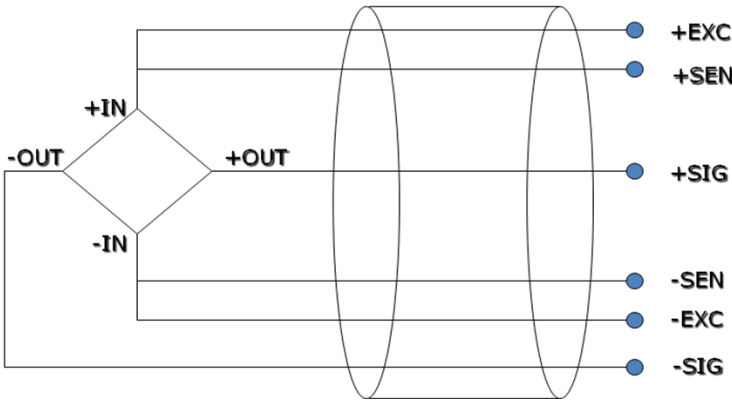

4 wires mode:

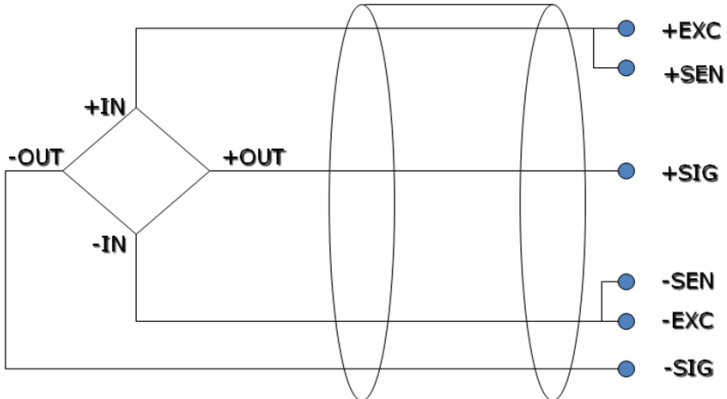

6-4. Weighing system

A typical weighing system:

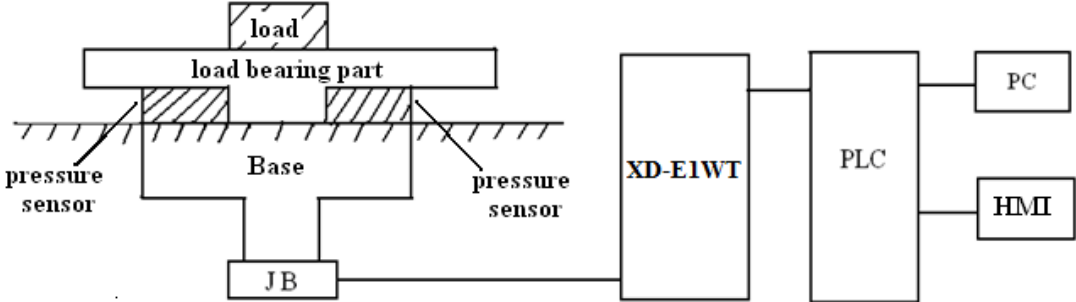

Loading bearing part: to support the load. Such as flat, hopper, container, air transport car...

Pressure sensor: transform the weight to voltage signal.

Assembly part: make sure the pressure sensor can work correctly, assembly part and direct part can avoid overload. Overload will cause measurement error and sensor damage.

Connection box (JB): to collect several sensor signals.

XD-E1WT-A: can be used as an electronic assessment device, it gets the pressure sensor signal and makes further assessment.

6-5. Module functions

XD-E1WT has the follow functions:

- Adjust the pressure sensor
- Collect the pressure sensor signal
- Calculate the weight value
- 0~39.06mV voltage signal test

6-5-1. Pressure sensor

The pressure sensor is based on resistance strain effect, see the following diagram:

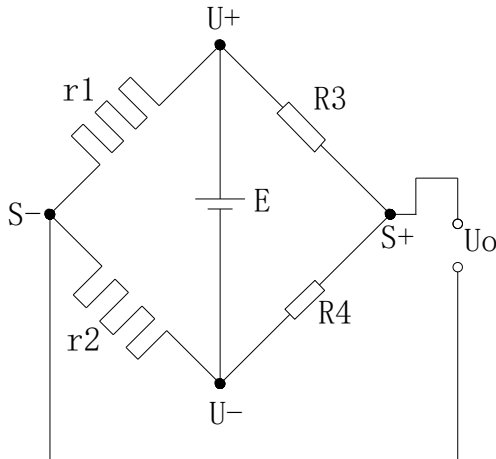

R1 and R2 is strain resistor which make bridge circuit with R3 and R4. With the change of R1 and R2, the bridge circuit will lose the balance, unbalance voltage U_o will be produced as the output of sensor.

$U+$ and $U-$ are positive and negative point of the sensor power supply. Please select the 5V power of the module or from outside.

$S+$ and $S-$ are positive and negative point of the sensor output. Connect the output to the module to test the weight.

6-6. I/O address

Expansion module no.1 register address:

Soft component	Channel	address	Explanation	Mark
Output coil	CH1	Y10000	Fast sampling enable, ON is fast sampling, OFF is slow	

			sampling	
		Y10001	Write in user-defined parameter	
		Y10002	Set to zero	
		Y10003	Calibration/resonance measurement	
Input coil	CH1	X10000	CH1 resonance frequency measurement complete flag	
Input register	CH1	ID10000	Present digital value	dword
		ID10002	Present weight	dword

Expansion module no.2 register address:

Soft component	Channel	Address	Explanation	Mark
Output coil	CH1	Y10100	Fast sampling enable, ON is fast sampling, OFF is slow sampling	
		Y10101	Write in user-defined parameter	
		Y10102	Set to zero	
		Y10103	Calibration/resonance measurement	
Input coil	CH1	X10100	CH1 resonance frequency measurement complete flag	
Input register	CH1	ID10100	Present digital value	dword
		ID10102	Present weight	dword

.....

Expansion module no.16 register address:

Soft component	Channel	Address	Explanation	Mark
Output coil	CH1	Y11500	Fast sampling enable, ON is fast sampling, OFF is slow sampling	
		Y11501	Write in user-defined parameter	
		Y11502	Set to zero	
		Y11503	Calibration/resonance measurement	
Input coil	CH1	X11500	CH1 resonance frequency measurement complete flag	
Input register	CH1	ID11500	Present digital value	dword
		ID11502	Present weight	dword

6-7. Working mode

There are two modes to set the working mode:

1. set through the control panel
2. set through the Flash register

Open the PLC software, click configure/expansion module settings:

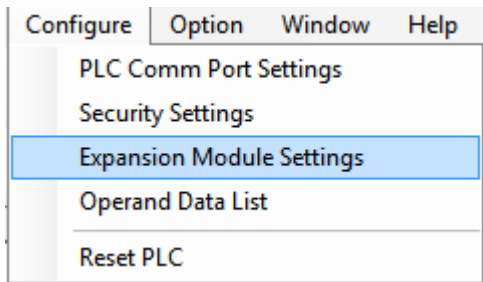

Choose suitable model information:

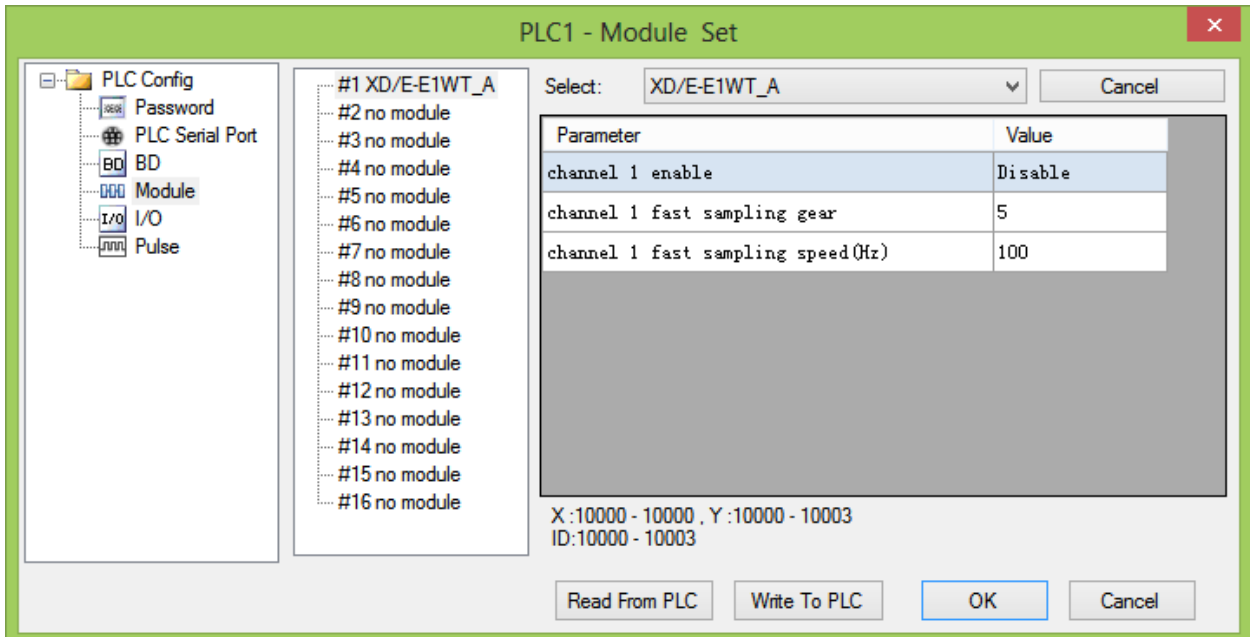

Flash register setting:

The expansion module can set gear and user-defined fast sampling frequency through the PLC internal flash register SFD.

Module no.	SFD address	Module no.	SFD address
#1	SFD350~SFD359	#9	SFD430~SFD439
#2	SFD360~SFD369	#10	SFD440~SFD449
#3	SFD370~SFD379	#11	SFD450~SFD459
#4	SFD380~SFD389	#12	SFD460~SFD469
#5	SFD390~SFD399	#13	SFD470~SFD479
#6	SFD400~SFD409	#14	SFD480~SFD489

#7	SFD410~SFD419	#15	SFD490~SFD499
#8	SFD420~SFD429	#16	SFD500~SFD509

SFD350~SFD359 register explanation:

SFD		Bit7	Bit6	Bit5	Bit4	Bit3	Bit2	Bit1	Bit0		
SFD350	Byte0				CH1 enable					Slow sampling default speed is 5Hz, fast sampling has 15 user-defined speed gears	
	Byte1					CH1 fast sampling gear (0-15)					
SFD351	Byte2										
	Byte3	CH1 user-defined fast sampling speed (Hz) (10-255)									
SFD352	Byte4										
	Byte5										
SFD353	Byte6										
	Byte7										
SFD354	Byte8										
	Byte9										
SFD355	Byte10										
	Byte11										
SFD356	Byte12										
	Byte13										
SFD357	Byte14										
	Byte15										
SFD358	Byte16										
	Byte17										
SFD359	Byte18										
	Byte19										

6-8. Module setting

Take module no.1 as an example:

Weight unit setting:

Write in weight through instruction TO. For example, the object weight is 1kg, write in 1 means the unit is kg, write in 1000 means the unit is g, write in 10000 means the unit is 0.1g.

Sampling frequency:

Sampling frequency includes fast sampling and slow sampling. The two states can be switched through Y10003. The default frequency of slow sampling is 5Hz. The fast sampling has 15 gears which can be selected in PLC expansion module configuration table. Each gear from 0 to 14 has different sampling frequency and

filter parameters. User can choose suitable gear as actual needs, please refer to default gear parameter table. Gear 15 is user-defined mode, it can set the sampling frequency and filter parameter by user. User can set the fast sampling frequency (this parameter is invalid for other gears) by software and set the filter parameter by instruction FROM and TO.

Resonance frequency measurement:

1. resonance frequency is the fixed vibration interference generated by machine, it will be tested when installing the machine at the beginning.
2. repower on the module or write in 0 for the weight by instruction FROM and TO.
3. switch to fast sampling mode (Y10000 is ON), set on Y10003. The module will enter resonance frequency measurement. Then set OFF Y10003. X10000 will be ON when the measurement completed. The result will be automatic saved in the module. (it is necessary to test the resonance frequency in fast sampling mode)

Calibration:

Please calibrate the pressure sensor for the first time using.

Take module channel 1 as an example:

1. make sure the module connected to the weighting system. Please check if the value in ID10000 fluctuated(the fluctuation range is related to sensor range), the pressure value is increasing as the load increasing. If ID10000 has no value, please check the sensor wiring. If the pressure value is decreasing as the load increasing, the sensor positive and negative point may connect backward.
2. close fast sampling enable bit Y10000 before calibration.
3. make the pressure sensor without load, set to zero after the scale is stable, set ON Y10002(set to zero enable bit).
4. put the load on the scale, write in the load weight by instruction TO, calibrate the system after the scale is stable, set ON Y10003(calibration enable bit). The calibration completed when ID10002 is same to the load weight, set OFF Y10003.
5. Hereto, the calibration finished. The module will automatic adjust the result according to the idle load value and calibration value when weighing, and finally get the correct weight.

Default gear parameter:

Speed gear	Fast sampling speed (Hz)	Fast sampling filter width	Kalman filter depth	IIR bandwidth coefficient	IIR attenuation ratio coefficient	Lowpass cut-off frequency
0	60	5	30	10	10	10
1	80	5	40	10	10	10
2	100	10	50	10	10	10
3	120	10	60	10	10	10
4	140	15	70	10	10	15
5	160	15	80	10	10	15
6	180	20	90	10	10	15
7	200	20	100	10	10	15
8	220	25	110	10	10	15
9	240	25	120	10	10	15

10	250	25	125	10	10	15
11	250	25	125	10	10	15
12	250	25	125	10	10	15
13	250	25	125	10	10	15
14	255	25	125	10	10	15

6-9. Instruction FROM and TO

Write instruction TO

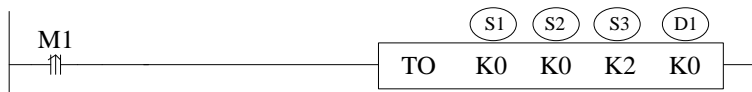

Function: write the PLC register data to module specified address, the unit is word.

Operand:

S1: target module number. Operand: K, TD, CD, D, FD.

S2: module first address. Operand: K, TD, CD, D, FD.

S3: write in register quantity. Operand: K, TD, CD, D, FD.

D1: write in data first address in PLC.

Read instruction FROM

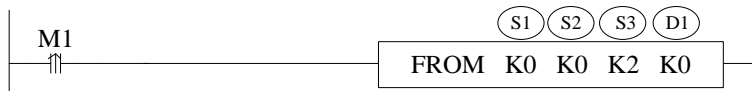

Function: read the module data to PLC register, the unit is word.

Operand:

S1: target module number. Operand: K, TD, CD, D, FD.

S2: module first address. Operand: K, TD, CD, D, FD.

S3: read register quantity. operand: K, TD, CD, D, FD.

D1: PLC register first address.

Module parameter internal address:

From/ToData		
K0	CH1 calibration weight	Dword
K2	CH1 fast sampling filter width	Word
K3	CH1 filter depth	Word
K4	CH1 bandwidth coefficient	Word
K5	CH1 attenuation coefficient	Word
K6	CH1 low pass cutoff frequency	Word
K7	CH1 resonance frequency (0.1HZ)	Word

Parameter explanation:

1. calibration weight: write in weight when calibrating
2. fast sampling filter width: the average times of fast sampling filter
3. attenuation coefficient: the larger the more stable, but too large will make the sampling value distortion and sensitivity reduction.
4. bandwidth coefficient: the larger the more stable, but too large will make the sampling value distortion and sensitivity reduction.
5. resonance frequency: the scale has natural frequency, this frequency can be known by internal measurement. The more accurate of the frequency, the better the filtering effect.
6. Filter depth: the larger the data, more stable the system, the lower the sensitivity.

6-10. A/D transformation diagram

The relationship between input voltage value and A/D transformed digital value:

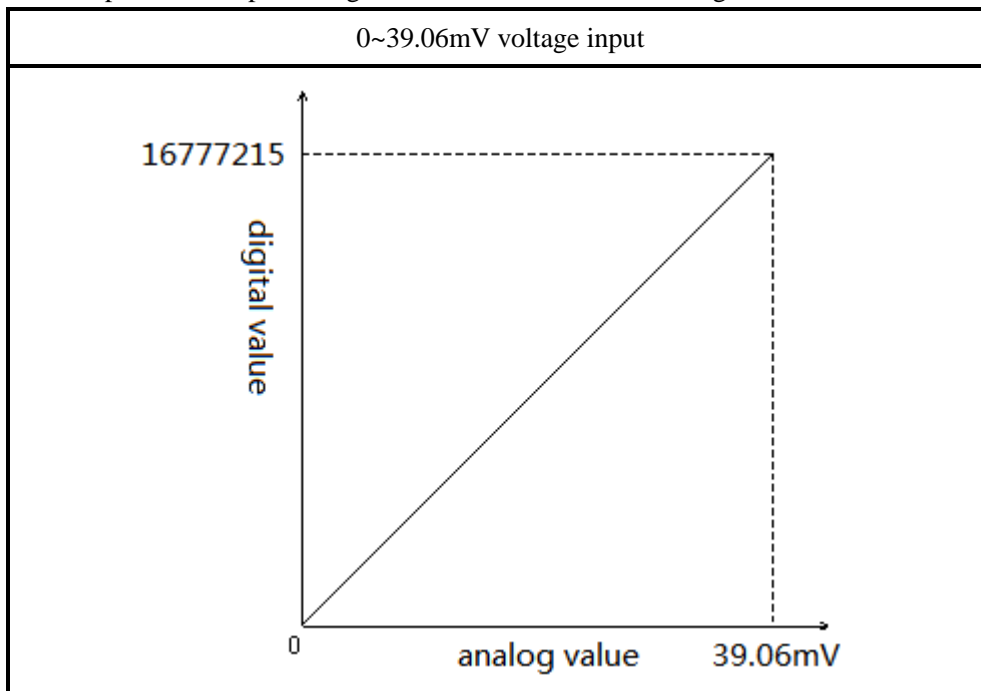

6-11. Application program

Take module 1 channel 1 as an example:

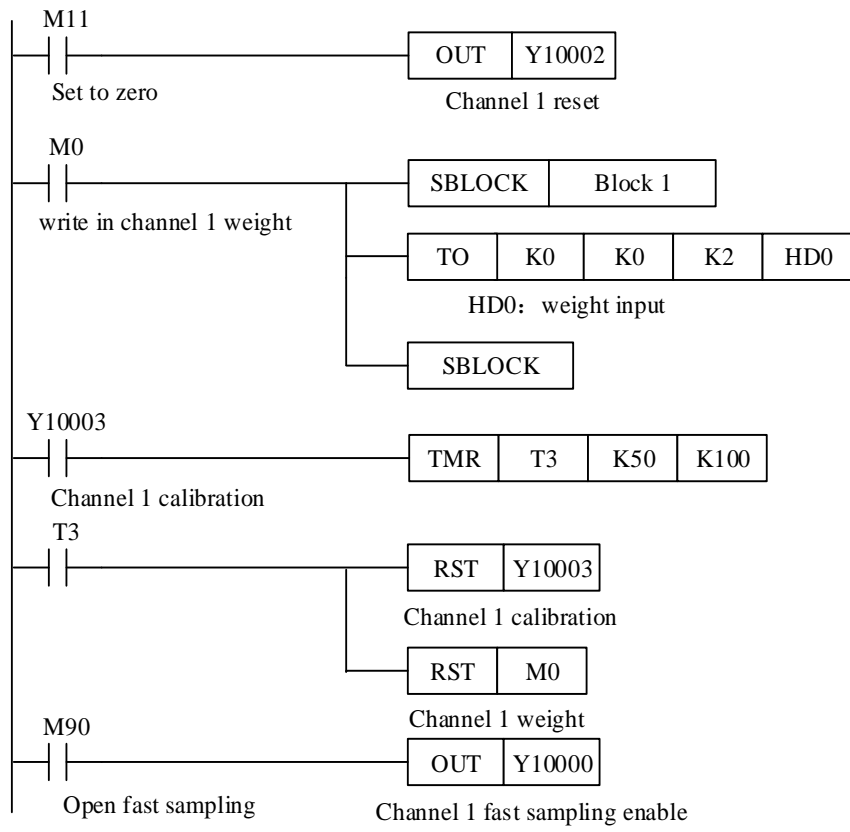

Explanation:

Reset through Y10002.

Write in the load weight through TO instruction. First store the weight value in HD0, set ON M1, write the value of HD0 to module 1 channel 1.

Calibrate through Y10003. The calibration is finished when the weight value is equal to the weight display value.

Switch the slow/fast sampling through Y10000.

Y10000 open, channel 1 will collect data with fast sampling frequency.

Y10000 close, channel 1 will collect data with slow sampling frequency.

7. 2 channels pressure module XD-E2WT-A

7-1. Features

XD-E2WT-A is the expansion module of XD series PLC. It can test the voltage in the range of 0mV~39.06mV or the voltage signal from pressure sensor. Then it can transform the voltage to digital value through A/D transformation and do calculation.

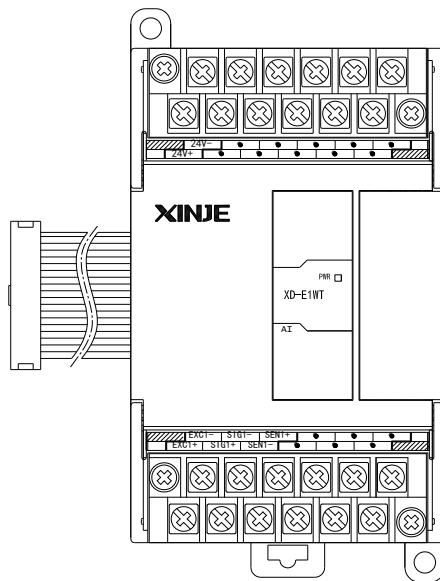

- 2 channels pressure sensor voltage signal input
- Test voltage signal in the range of 0~39.06mV
- 24-bit A/D transformation
- XD3 series PLC can connect 10 XD-E2WT-A modules
- XDM series PLC can connect 16 XD-E2WT-A modules

Input range	DC 0~39.06mV
Resolution	1/8388608 (24Bit)
Integrated precision	0.1%
Transformation speed	0-250 times/second
Power supply	DC24V ±10%, 100mA
Sensor power supply	5VDC/120mA, can parallel 4 pieces of 350Ω pressure sensor
Installation	Mount on DIN46277 rail (width 35mm) or fix with screw M3
Dimension	63mm×108mm×79.9mm
Working environment	No corrosive gas
Ambient temperature	0°C~60°C
Humidity	5~95%
Software version	V3.2 and higher version

7-2. Terminals

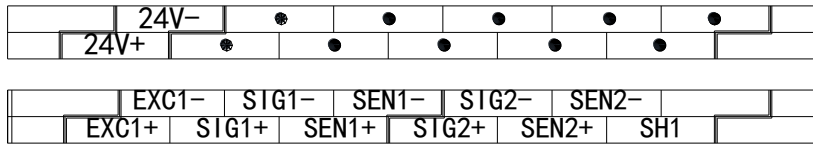

Channel	Terminal	Signal	Meaning
CH1	EXC1+	Excitation+	Connect to sensor power supply input
	EXC1-	Excitation-	
	SIG1+	Signal +	Connect to sensor signal output
	SIG1-	Signal -	
	SEN1+	Feedback +	Connect to sensor feedback voltage output
	SEN1-	Feedback -	
	SH1	Shield	Connect to sensor ground
CH2	EXC2+	Excitation+	Connect to sensor power supply input
	EXC2-	Excitation-	
	SIG2+	Signal +	Connect to sensor signal output
	SIG2-	Signal -	
	SEN2+	Feedback +	Connect to sensor feedback voltage output
	SEN2-	Feedback -	
	SH2	Shield	Connect to sensor ground
	24V	+24V power supply	Module power supply
	0V	Common terminal	

7-3. External connection

For external connection, please note the following cases:

- Please use the 24V power supply on the PLC to avoid interference.
- Please use shield cable and single-point connect to the ground.

Power supply wiring

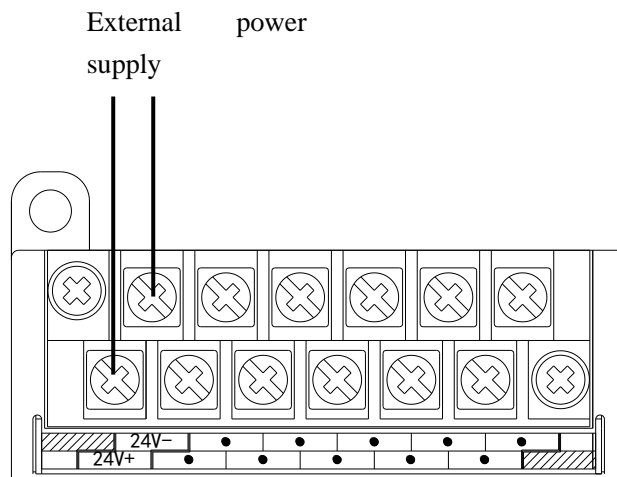

Connect to sensor

6 wires sensor:

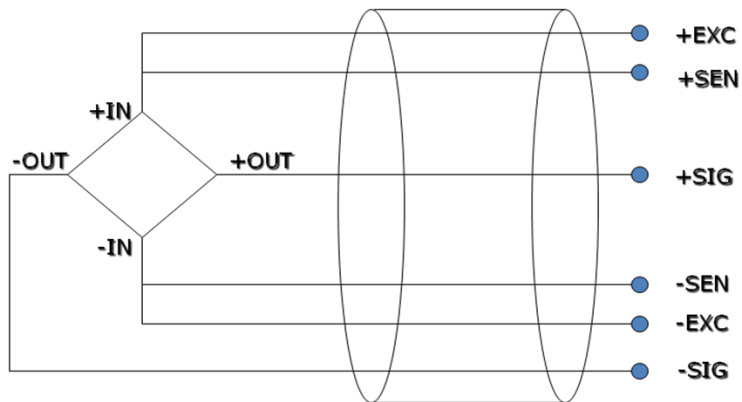

4 wires sensor:

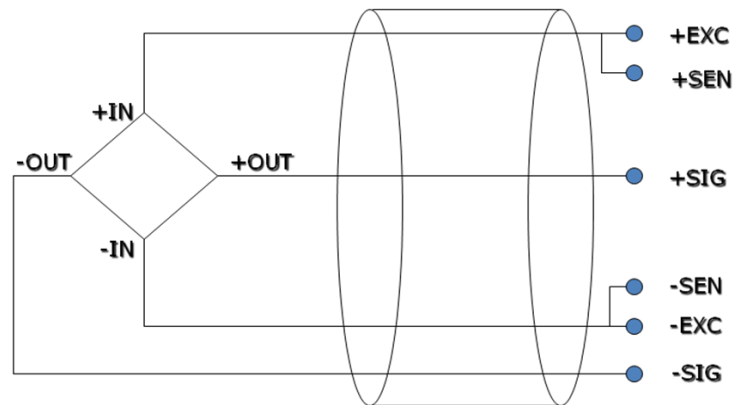

Notes: if the sensor is 4 wires mode, please connect EXC1- and SEN1-, EXC1+ and SEN1+.

7-4. Weighing system

A typical weighing system:

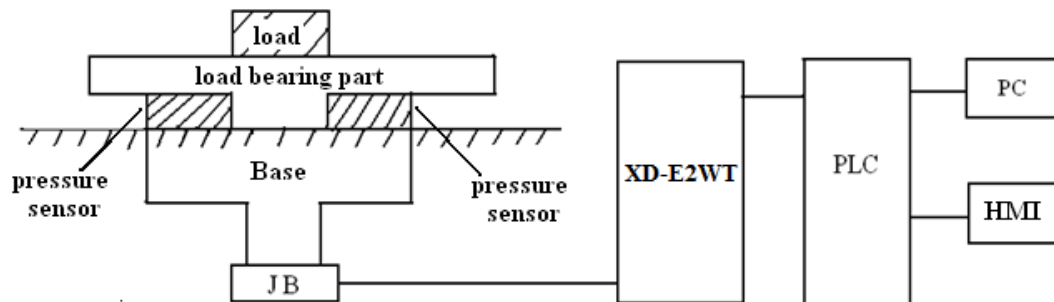

Loading bearing part: to support the load. Such as flat, hopper, container, air transport car...

Pressure sensor: transform the weight to voltage signal.

Assembly part: make sure the pressure sensor can work correctly, assembly part and direct part can avoid overload. Overload will cause measurement error and sensor damage.

Connection box (JB): to collect several sensor signals.

XD-E2WT: can be used as an electronic assessment device, it gets the pressure sensor signal and makes further assessment.

7-5. Module functions

XD-E2WT-A has the follow functions:

- Adjust the pressure sensor
- Collect the pressure sensor signal
- Calculate the weight value
- 0~39.06mV voltage signal test

7-5-1. Pressure sensor

The pressure sensor is based on resistance strain effect, see the following diagram:

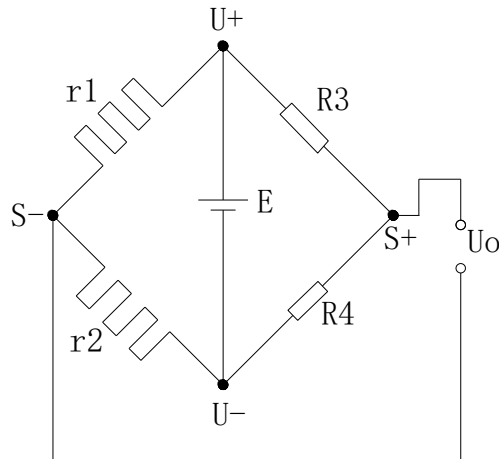

R_1 and R_2 is strain resistor which make bridge circuit with R_3 and R_4 . With the change of R_1 and R_2 , the bridge circuit will lose the balance, unbalance voltage U_o will be produced as the output of sensor.

U^+ and U^- are positive and negative point of the sensor power supply. Please select the 5V power of the module or from outside.

S^+ and S^- are positive and negative point of the sensor output. Connect the output to the module to test the weight.

7-6. I/O address

Expansion module no.1 register address

Soft component		Address	Explanation	Mark
Output coil	CH1	Y10000	Fast sampling enable , ON is fast sampling, OFF is slow sampling	
		Y10001	Write in user-defined parameters	
		Y10002	Reset	
		Y10003	Calibration/resonance measurement	
	CH2	Y10004	Fast sampling enable , ON is fast sampling, OFF is slow sampling	
		Y10005	Write in user-defined parameters	
		Y10006	Reset	
		Y10007	Calibration/resonance measurement	
Input coil	CH1	X10000	CH1 resonance frequency measurement complete flag	
	CH2	X10001	CH2 resonance frequency measurement complete flag	
Input register	CH1	ID10000	Present digital value	Dword
		ID10002	Present weight	Dword

	CH2	ID10004	Present digital value	Dword
		ID10006	Present weight	Dword

Expansion module no.2 register address

Soft component		Address	Explanation	Mark
Output coil	CH1	Y10100	Fast sampling enable , ON is fast sampling, OFF is slow sampling	
		Y10101	Write in user-defined parameters	
		Y10102	Reset	
		Y10103	Calibration/resonance measurement	
	CH2	Y10104	Fast sampling enable , ON is fast sampling, OFF is slow sampling	
		Y10105	Write in user-defined parameters	
		Y10106	Reset	
		Y10107	Calibration/resonance measurement	
Input coil	CH1	X10100	CH1 resonance frequency measurement complete flag	
	CH2	X10101	CH2 resonance frequency measurement complete flag	
Input register	CH1	ID10100	Present digital value	Dword
		ID10102	Present weight	Dword
	CH2	ID10104	Present digital value	Dword
		ID10106	Present weight	Dword

.....

Expansion module no.16 register address

Soft component		Address	Explanation	Mark
Output coil	CH1	Y11500	Fast sampling enable , ON is fast sampling, OFF is slow sampling	
		Y11501	Write in user-defined parameters	
		Y11502	Reset	
		Y11503	Calibration/resonance measurement	
	CH2	Y11504	Fast sampling enable , ON is fast sampling, OFF is slow sampling	
		Y11505	Write in user-defined parameters	
		Y11506	Reset	
		Y11507	Calibration/resonance measurement	
Input coil	CH1	X11500	CH1 resonance frequency measurement complete flag	

	CH2	X11501	CH2 resonance frequency measurement complete flag	
Input register	CH1	ID11500	Present digital value	Dword
		ID11502	Present weight	Dword
	CH2	ID11504	Present digital value	Dword
		ID11506	Present weight	Dword

7-7. Working mode

There are two modes to set the working mode:

1. set through the control panel
2. set through the Flash register

Open the PLC software, click configure/expansion module settings:

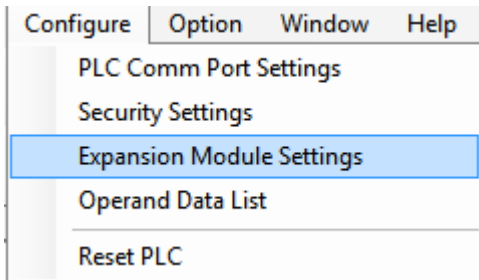

Choose suitable model information:

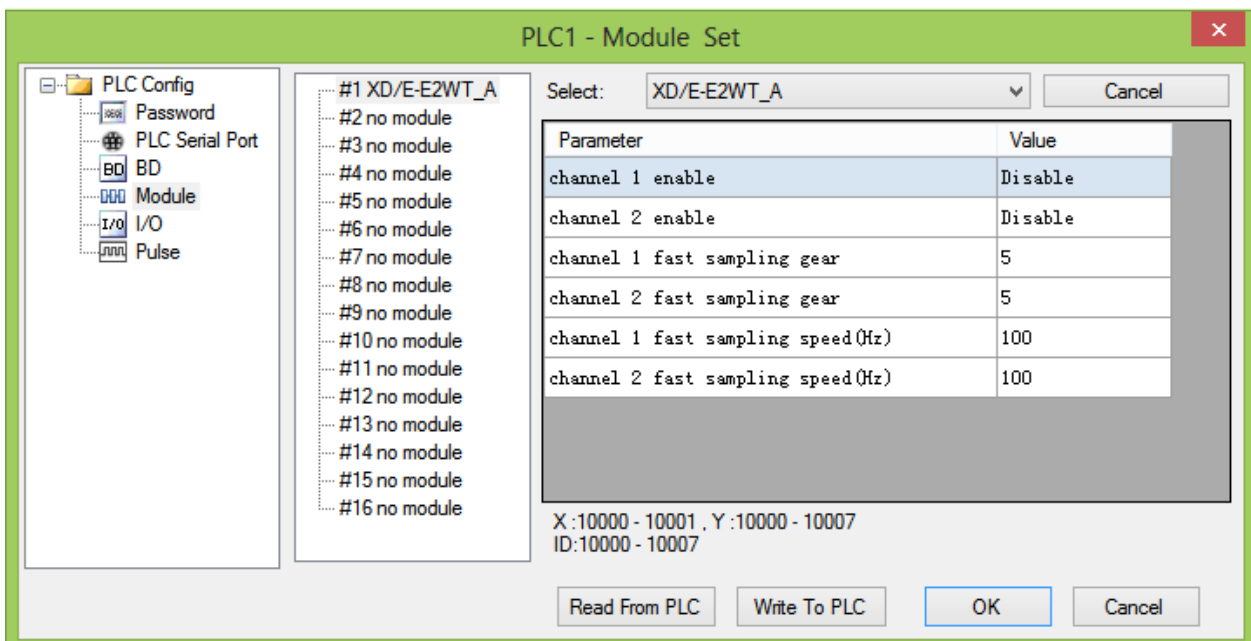

Flash register setting:

The expansion module can set gear and user-defined fast sampling frequency through the PLC internal flash register SFD.

Module no.	SFD address	Module no.	SFD address
#1	SFD350~SFD359	#9	SFD430~SFD439
#2	SFD360~SFD369	#10	SFD440~SFD449
#3	SFD370~SFD379	#11	SFD450~SFD459
#4	SFD380~SFD389	#12	SFD460~SFD469
#5	SFD390~SFD399	#13	SFD470~SFD479
#6	SFD400~SFD409	#14	SFD480~SFD489
#7	SFD410~SFD419	#15	SFD490~SFD499
#8	SFD420~SFD429	#16	SFD500~SFD509

SFD350~SFD359 register explanation:

SFD	Bit7	Bit6	Bit5	Bit4	Bit3	Bit2	Bit1	Bit0		
SFD350	Byte0			CH2 enable	CH1 enable					
	Byte1	CH2 fast sampling gear (0-15)			CH1 fast sampling gear (0-15)					
SFD351	Byte2									
	Byte3	CH1 user-defined fast sampling speed (Hz) (10-255)								
SFD352	Byte4	CH2 user-defined fast sampling speed (Hz) (10-255)								
	Byte5									
SFD353	Byte6									
	Byte7									
SFD354	Byte8									
	Byte9									
SFD355	Byte10									
	Byte11									
SFD356	Byte12									
	Byte13									
SFD357	Byte14									
	Byte15									
SFD358	Byte16									

Slow sampling default speed is 5Hz, fast sampling has 15 user-defined speed gears

	Byte17		
SFD359	Byte18		
	Byte19		

7-8. Module setting

Take module no.1 channel 1 as an example:

Weight unit setting:

Write in weight through instruction TO. For example, the object weight is 1kg, write in 1 means the unit is kg, write in 1000 means the unit is g, write in 10000 means the unit is 0.1g.

Sampling frequency:

Sampling frequency includes fast sampling and slow sampling. The two states can be switched through Y10003. The default frequency of slow sampling is 5Hz. The fast sampling has 15 gears which can be selected in PLC expansion module configuration table. Each gear from 0 to 14 has different sampling frequency and filter parameters. User can choose suitable gear as actual needs, please refer to default gear parameter table. Gear 15 is user-defined mode, it can set the sampling frequency and filter parameter by user. User can set the fast sampling frequency (this parameter is invalid for other gears) by software and set the filter parameter by instruction FROM and TO.

Resonance frequency measurement:

1. resonance frequency is the fixed vibration interference generated by machine, it will be tested when installing the machine at the beginning.
2. repower on the module or write in 0 for the weight by instruction FROM and TO.
3. switch to fast sampling mode (Y10000 is ON), set on Y10003. The module will enter resonance frequency measurement. Then set OFF Y10003. X10000 will be ON when the measurement completed. The result will be automatic saved in the module. (it is necessary to test the resonance frequency in fast sampling mode)

Calibration:

Please calibrate the pressure sensor for the first time using.

Take module channel 1 as an example:

1. make sure the module connected to the weighting system. Please check if the value in ID10000 fluctuated(the fluctuation range is related to sensor range), the pressure value is increasing as the load increasing. If ID10000 has no value, please check the sensor wiring. If the pressure value is decreasing as the load increasing, the sensor positive and negative point may connect backward.
2. close fast sampling enable bit Y10000 before calibration.
3. make the pressure sensor without load, set to zero after the scale is stable, set ON Y10002(set to zero enable bit).
4. put the load on the scale, write in the load weight by instruction TO, calibrate the system after the scale is stable, set ON Y10003(calibration enable bit). The calibration completed when ID10002 is same to the load weight, set OFF Y10003.
5. Hereto, the calibration finished. The module will automatic adjust the result according to the idle load value and calibration value when weighing, and finally get the correct weight.

Default gear parameter:

Speed gear	Fast sampling speed (Hz)	Fast sampling filter width	Kalman filter depth	IIR bandwidth coefficient	IIR attenuation ratio coefficient	Lowpass cut-off frequency
0	60	5	30	10	10	10
1	80	5	40	10	10	10
2	100	10	50	10	10	10
3	120	10	60	10	10	10
4	140	15	70	10	10	15
5	160	15	80	10	10	15
6	180	20	90	10	10	15
7	200	20	100	10	10	15
8	220	25	110	10	10	15
9	240	25	120	10	10	15
10	250	25	125	10	10	15
11	250	25	125	10	10	15
12	250	25	125	10	10	15
13	250	25	125	10	10	15
14	255	25	125	10	10	15

7-9. Instruction FROM and TO

Write instruction TO

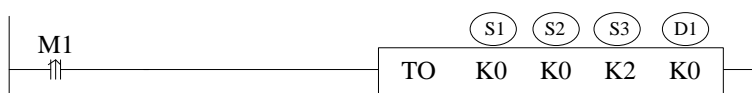

Function: write the PLC register data to module specified address, the unit is word.

Operand:

S1: target module number. Operand: K, TD, CD, D, FD.

S2: module first address. Operand: K, TD, CD, D, FD.

S3: write in register quantity. Operand: K, TD, CD, D, FD.

D1: write in data first address in PLC.

Read instruction FROM



Function: read the module data to PLC register, the unit is word.

Operand:

S1: target module number. Operand: K, TD, CD, D, FD.

S2: module first address. Operand: K, TD, CD, D, FD.

S3: read register quantity. operand: K, TD, CD, D, FD.

D1: PLC register first address.

Module parameter internal address:

From/ToData		
K0	CH1 calibration weight	Dword
K2	CH1 fast sampling filter width	Word
K3	CH1 filter depth	Word
K4	CH1 bandwidth coefficient	Word
K5	CH1 attenuation coefficient	Word
K6	CH1 low pass cutoff frequency	Word
K7	CH1 resonance frequency (0.1HZ)	Word
K8	CH2 calibration weight	Dword
K10	CH2 fast sampling filter width	Word
K11	CH2 filter depth	Word
K12	CH2 bandwidth coefficient	Word
K13	CH2 attenuation coefficient	Word
K14	CH2 low pass cutoff frequency	Word
K15	CH2 resonance frequency (0.1HZ)	Word

Parameter explanation:

1. calibration weight: write in weight when calibrating
2. fast sampling filter width: the average times of fast sampling filter
3. attenuation coefficient: the larger the more stable, but too large will make the sampling value distortion and sensitivity reduction.
4. bandwidth coefficient: the larger the more stable, but too large will make the sampling value distortion and sensitivity reduction.
5. resonance frequency: the scale has natural frequency, this frequency can be known by internal measurement. The more accurate of the frequency, the better the filtering effect.
6. Filter depth: the larger the data, more stable the system, the lower the sensitivity.

7-10. A/D transformation diagram

The relationship between input voltage value and A/D transformed digital value:

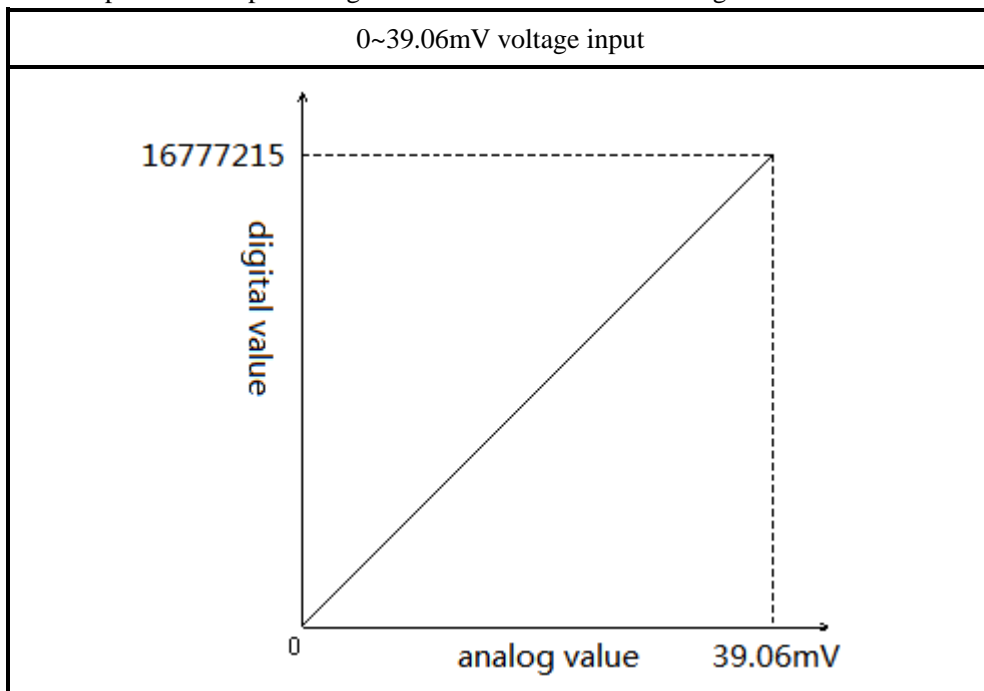

7-11. Application program

Take module 1 channel 1 as an example:

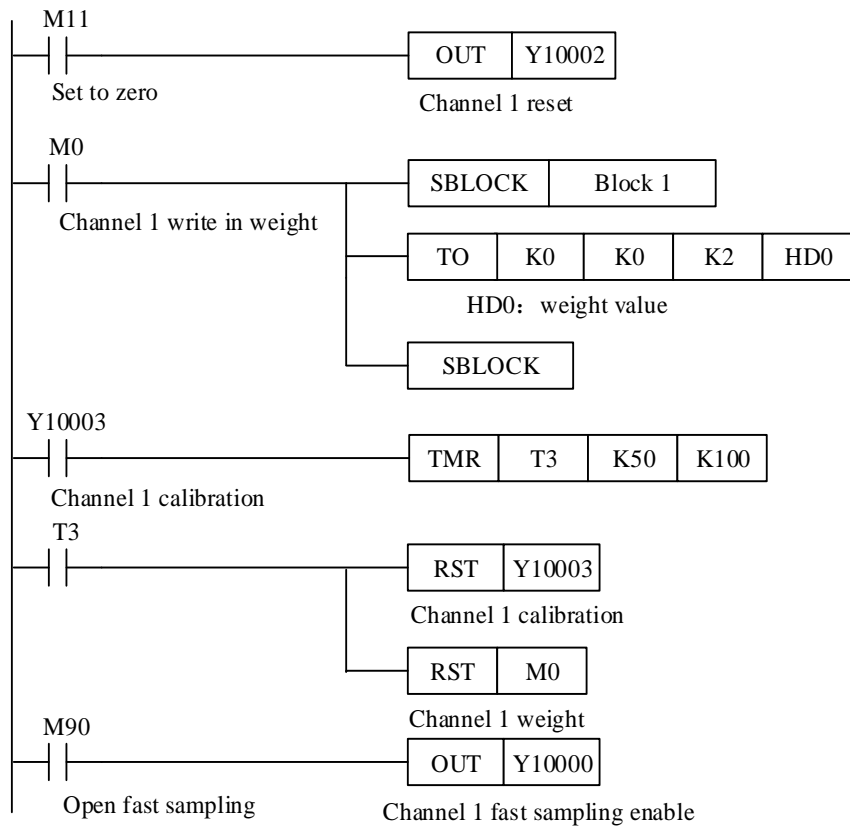

Explanation:

Set to zero through Y10002.

Write in the weight value through instruction TO. First store the weight value in HD0, set ON M0, write the value of HD0 to module 1 channel 1.

Calibrate the scale through Y10003. The calibration is finished when the weight value is equal to the weight display value.

Switch the slow/fast sampling through Y10000.

Y10000 open, channel 1 will collect data with fast sampling frequency.

Y10000 close, channel 1 will collect data with slow sampling frequency.

8. Pt100 temperature control module XD-E6PT-P

8-1. Specification

XD-E6PT-P can collect the temperature signal from PT100 sensor, it has PID function.

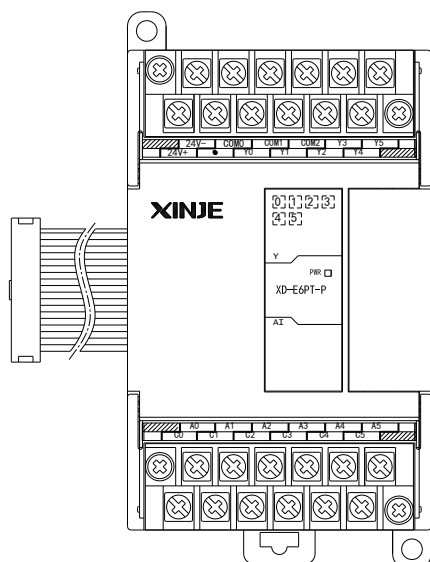

- Platinum thermal resistance input, Pt100
- 6 channels input, 6 channels output
- 6 groups PID parameters, auto-tune function
- 1mA constant current output, will not be affected by the exterior environment
- Resolution is 0.1°C
- As the special function module of XD3, 10 modules can be connected to the PLC. (XDM can connect 16 modules)

Item	Content
Analog input signal	Pt100 platinum thermal-resistance
Temperature measurement range	-100°C ~ 500°C
Digital output bound	-1000~5000, 16 bits with sign bit, binary
Control precision	±0.5°C
Resolution	0.1°C
Integrate precision	1% (relative max value)
Conversion speed	20ms per channels
Analog power	DC24V ±10%, 50mA
Installation format	Fixed with M3 screws or directly installed on orbit of DIN46277 (Width: 35mm)
Dimension	63mm×108mm×79.9mm

Note:

1. Without signal input, the channel data will be 5000
2. Connect to Pt100 platinum thermal resistance according to actual requirements

8-2. Terminals

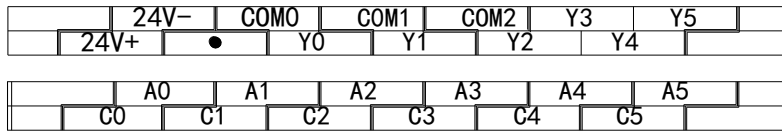

Channel	Terminal name	Signal name
CH0	A0	0CH PT100 input
	C0	0CH common terminal of PT100 input
CH1	A1	1CH PT100 input
	C1	1CH common terminal of PT100 input
CH2	A2	2CH PT100 input
	C2	2CH common terminal of PT100 input
CH3	A3	3CH PT100 input
	C3	3CH common terminal of PT100 input
CH4	A4	4CH PT100 input
	C4	4CH common terminal of PT100 input
CH5	A5	5CH PT100 input
	C5	5CH common terminal of PT100 input
-	Y0	Channel 0 output
	Y1	Channel 1 output
	Y2	Channel 2 output
	Y3	Channel 3 output
	Y4	Channel 4 output
	Y5	Channel 5 output
	COM0	Common terminal of output
	COM1	Common terminal of output
-	24V+	+24V power supply
	24V-	Common terminal of power supply

8-3. I/O address assignment

XD series analog modules don't occupy I/O units; the converted data is directly transferred into PLC register. The PLC registers are shown as the following:

Parameters	Explanation				
	Channel	Ch0	Ch1	Ch5
Display temperature Unit: 0.1 °C	Module 1	ID10000	ID10001	ID1000×	ID10005
	Module 2	ID10100	ID10101	ID10X0×	ID10105
	ID10X00	ID10X01	ID10X0×	ID10X05
	Module 16	ID11500	ID11501	ID1150×	ID11505
PID output (return to the X input of PLC)	Module 1	X10000	X10001	X1000×	X10005
	Module 2	X10100	X10101	X1010×	X10105
	X10×00	X10×01	X10×0×	X10×05
	Module 16	X11700	X11701	X1170×	X11705
Connection state of PT100 (0 is connection, 1 is disconnection)	Module 1	X10010	X10011	X1001×	X10015
	Module 2	X10110	X10111	X1011×	X10115
	X10××0	X10××1	X10×××	X10××5
	Module 16	X11710	X11711	X1171×	X11715
Enable signal	Module 1	Y10000	Y10001	Y1000×	Y10005
	Module 2	Y10100	Y10101	Y1010×	Y10105
	Y1××00	Y1××01	Y1××0×	Y1××05
	Module 16	Y11700	Y11701	Y1170×	Y11705
PID auto-tune error signal bit(0 is normal, 1 is error)	Module 1	X10020	X10021	X1002X	X10025
	Module 2	X10120	X10121	X1012×	X10125
	X1××20	X1××21	X1××2×	X1××25
	Module 16	X11720	X11721	X1172×	X11725
PID control bit	Auto-tune triggered signal, start to auto-tune mode when set to 1 After auto-tune, PID parameters and temperature control period value are refreshed, the bit value is cleared to be 0. The user can read the bit to know the state. 1 means auto-tune is ongoing. 0 means auto-tune has finished.				
PID output (The result)	Digital quantity output range is 0~4095. When the PID output is analog quantity (such as steam valve open degree or silicon-controlled conduction angle), the value can be transmitted to the analog quantity output module in order to realize the control demand.				
PID parameters (P, I, D)	The best PID parameters got from the PID auto-tune. If the current PID parameters cannot meet the control requirements, users can set the experience PID parameters to make the module work according to the user setting value.				
PID calculation range (Diff) Unit: 0.1°C	PID arithmetic is effective in the range of T (setting temperature) ±Diff. In real temperature control environment, when the temperature is lower than T- Diff, the PID output is the maximum value; when the temperature is higher than T+Diff, the PID output is the minimum value.				
Temperature difference value δ Unit: 0.1°C	(sampling temperature value + temperature difference value δ) / 10 = display temperature. At the time the display temperature is the most close to the real temperature. This parameter is a sign value with the unit of 0.1°C, the value is retained when th power is cut off, the defaulted value is 0.				
Set temperature Unit: 0.1°C	The target temperature of the control system. Range from 0~1000°C, precision degree is 0.1°C.				

Temperature control period Unit: 0.1s	The temperature control period range from 0.5 to 200 seconds, the minimum precision is 0.1 second. The set value = real value × 10. For example: if the real temperature control period is 0.5 seconds, user should set 5 seconds in the module.
Adjusting environment temperature Unit: 0.1°C	If user realizes that the environment temperature is different from display temperature, they can write the correct environment temperature into the module. Then the module will calculate the temperature difference δ and save it. Temperature difference δ = adjusting environment temperature – sampling temperature. Unit: 0.1°C. For example, under the caloric balance condition, users measured the environment temperature is 60°C with mercury thermometer, but the display temperature is 55°C (sampling temperature is 550), temperature difference δ is 5. At this time, users can set the parameter to be 600, then the temperature difference δ is 50 (5 °C). Display temperature = (550 + 50) / 10 = 60 °C. **Attention: when setting the adjusting environment temperature, make sure it is the same as environment temperature. It is very important because the incorrect parameter will result in mistake of calculating temperature difference δ and affect the display temperature.
auto-tune output range	The auto-tune output unit is percent. 100 means the duty ratio is 100% of the full-scale output, 80 means the duty ratio is 80% of the full-scale output.

FROM and TO instructions

(1) Parameter write instruction TO

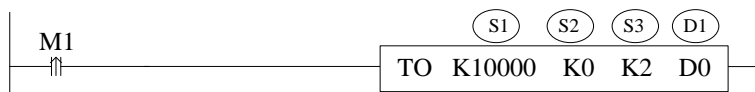

Function: write the PLC register data to module address, the operate unit is word.

Operand:

S1: target module number, range: 10000~10015. Operand: K, TD, CD, D, HD, FD

S2: first address of module. Operand: K, TD, CD, D, HD, FD

S3: write in register numbers. Operand: K, TD, CD, D, HD, FD

D1: first address of PLC. Operand: TD, CD, D, HD, FD

(2) Parameter read instruction FROM



Function: read the module data to the PLC register, the operate unit is word.

S1: target module number, range: 10000~10015. Operand: K, TD, CD, D, HD, FD

S2: first address of module. Operand: K, TD, CD, D, HD, FD

S3: read register numbers. Operand: K, TD, CD, D, HD, FD

D1: first address of PLC. Operand: TD, CD, D, HD, FD

Note:

1. FROM and TO only can be programmed in the sequence block, one program only supports 8 sequence blocks.
2. The module number range is 0 to 15 for the software version v3.3 and below.

Related address definition:

The address of the read/write parameters:

From_To data		CH1	CH2	CH3	CH4	CH5	CH6	R/W
Auto-tune enable		K0	K0	K0	K0	K0	K0	RW
PID output		K1	K2	K3	K4	K5	K6	R
Setting		K7	K8	K9	K10	K11	K12	RW
PID	Kp	K13	K17	K21	K25	K29	K33	RW
	Ki	K14	K18	K22	K26	K30	K34	RW
	Kd	K15	K19	K23	K27	K31	K35	RW
	Diff	K16	K20	K24	K28	K32	K36	RW
Temperature control period (unit: 0.1s)		K37	K38	K39	K40	K41	K42	RW
Output range (0~100)		K43	K44	K45	K46	K47	K48	RW
Temperature deviation calibration		K49	K50	K51	K52	K53	K54	RW
Present actual temperature, can be used to calibrate		K55	K56	K57	K58	K59	K60	W

Besides, the module can save the setting temperature, PID parameters, temperature difference value, temperature control period, auto-tune output range, etc. The parameters will be saved after auto-tune or user modification, and be operated after re-power on.

Module 1			Module 2		
Channel	Present temperature	PID start/stop bit	Channel	Present temperature	PID start/stop bit
0CH	ID10000	Y10000	0CH	ID10100	Y10100
1CH	ID10001	Y10001	1CH	ID10101	Y10101
2CH	ID10002	Y10002	2CH	ID10102	Y10102
3CH	ID10003	Y10003	3CH	ID10103	Y10103
4CH	ID10004	Y10004	4CH	ID10104	Y10104
5CH	ID10005	Y10005	5CH	ID10105	Y10105

Module 3			Module 4		
Channel	Present temperature	PID start/stop bit	Channel	Present temperature	PID start/stop bit
0CH	ID10200	Y10200	0CH	ID10300	Y10300
1CH	ID10201	Y10201	1CH	ID10301	Y10301
2CH	ID10202	Y10202	2CH	ID10302	Y10302
3CH	ID10203	Y10203	3CH	ID10303	Y10303
4CH	ID10204	Y10204	4CH	ID10304	Y10304
5CH	ID10205	Y10205	5CH	ID10305	Y10305

Module 5			Module 6		
Channel	Present temperature	PID start/stop bit	Channel	Present temperature	PID start/stop bit
0CH	ID10400	Y10400	0CH	ID10500	Y10500
1CH	ID10401	Y10401	1CH	ID10501	Y10501
2CH	ID10402	Y10402	2CH	ID10502	Y10502
3CH	ID10403	Y10403	3CH	ID10503	Y10503
4CH	ID10404	Y10404	4CH	ID10504	Y10504
5CH	ID10405	Y10405	5CH	ID10505	Y10505

Module 7			Module 8		
Channel	Present temperature	PID start/stop bit	Channel	Present temperature	PID start/stop bit
0CH	ID10600	Y10600	0CH	ID10700	Y10700
1CH	ID10601	Y10601	1CH	ID10701	Y10701
2CH	ID10602	Y10602	2CH	ID10702	Y10702
3CH	ID10603	Y10603	3CH	ID10703	Y10703
4CH	ID10604	Y10604	4CH	ID10704	Y10704
5CH	ID10605	Y10605	5CH	ID10705	Y10705

Module 9			Module 10		
Channel	Present temperature	PID start/stop bit	Channel	Present temperature	PID start/stop bit
0CH	ID10800	Y11000	0CH	ID10900	Y11100
1CH	ID10801	Y11001	1CH	ID10901	Y11101
2CH	ID10802	Y11002	2CH	ID10902	Y11102
3CH	ID10803	Y11003	3CH	ID10903	Y11103
4CH	ID10804	Y11004	4CH	ID10904	Y11104
5CH	ID10805	Y11005	5CH	ID10905	Y11105

Module 11			Module 12		
Channel	Present temperature	PID start/stop bit	Channel	Present temperature	PID start/stop bit
0CH	ID11000	Y11200	0CH	ID11100	Y11300
1CH	ID11001	Y11201	1CH	ID11101	Y11301
2CH	ID11002	Y11202	2CH	ID11102	Y11302
3CH	ID11003	Y11203	3CH	ID11103	Y11303
4CH	ID11004	Y11204	4CH	ID11104	Y11304
5CH	ID11005	Y11205	5CH	ID11105	Y11305

Module 13			Module 14		
Channel	Present temperature	PID start/stop bit	Channel	Present temperature	PID start/stop bit
0CH	ID11200	Y11400	0CH	ID11300	Y11500
1CH	ID11201	Y11401	1CH	ID11301	Y11501
2CH	ID11202	Y11402	2CH	ID11302	Y11502
3CH	ID11203	Y11403	3CH	ID11303	Y11503
4CH	ID11204	Y11404	4CH	ID11304	Y11504
5CH	ID11205	Y11405	5CH	ID11305	Y11505

Module 15			Module 16		
Channel	Present temperature	PID start/stop bit	Channel	Present temperature	PID start/stop bit
0CH	ID11400	Y11600	0CH	ID11500	Y11700
1CH	ID11401	Y11601	1CH	ID11501	Y11701
2CH	ID11402	Y11602	2CH	ID11502	Y11702
3CH	ID11403	Y11603	3CH	ID11503	Y11703
4CH	ID11404	Y11604	4CH	ID11504	Y11704
5CH	ID11405	Y11605	5CH	ID11505	Y11705

Description:

Start signal (Y): When Y is 0, close PID control; when Y is 1, start PID control.

8-4. Working mode

There are two ways to set the working mode:

1. XDPpro software
2. Flash registers of PLC

XDPpro software:

Open the XDPpro software, click configure/expansion module settings:

Set the model and channel parameters in the following window. Then click write to PLC.

Please restart the PLC after setting.

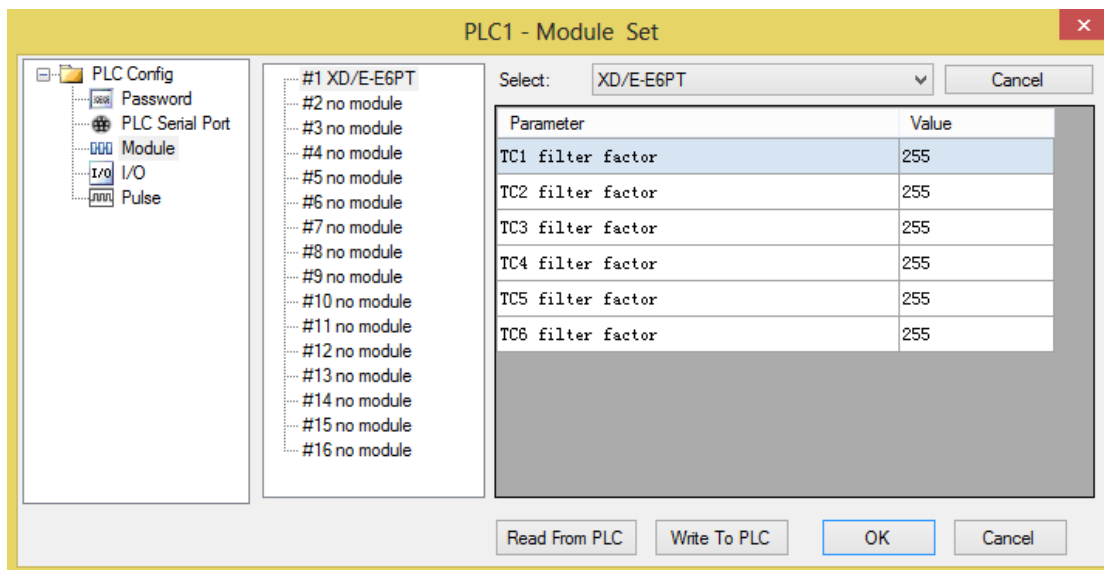

Flash registers:

Set the filter and control cycle through Flash registers of PLC.

Module no.	SFD address	Module no.	SFD address
#1	SFD350~SFD359	#9	SFD430~SFD439
#2	SFD360~SFD369	#10	SFD440~SFD449
#3	SFD370~SFD379	#11	SFD450~SFD459
#4	SFD380~SFD389	#12	SFD460~SFD469
#5	SFD390~SFD399	#13	SFD470~SFD479
#6	SFD400~SFD409	#14	SFD480~SFD489
#7	SFD410~SFD419	#15	SFD490~SFD499
#8	SFD420~SFD429	#16	SFD500~SFD509

SFD bit definition:

Filter mode and control cycle:

The module can set two working modes: filter mode and control cycle.

Control cycle: when the module is doing PID control, the output terminal will control the heating process in

certain period according to duty ratio calculated from PID output value. The certain period is control cycle.

Expansion module no.1 SFD setting:

	Bit7	Bit6	Bit5	Bit4	Bit3	Bit2	Bit1	Bit0	Explanation
Byte0	AD channel 2, channel 1 filter time								AD filter time
Byte1	AD channel 4, channel 3 filter time								
Byte2	AD channel 6, channel 5 filter time								
Byte3~Byte19	Reserved								

8-5. Exterior connection

About the external wiring, please see the following items:

- When connect +24V power, please use 24V power on PLC main unit to avoid interference.
- To avoid interference, please use shield cable to ground.

Input connection:

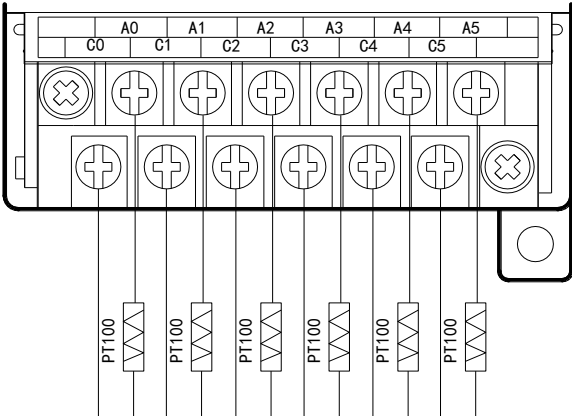

Output connection:

- Output terminals: transistor output terminal please choose DC 5V~30V power supply.
- Circuit insulation
PLC interior circuit and output transistor is optical insulation. Each public module is also separated.
- Response time
The time is less than 0.2ms from PLC driving (or cut) optical coupling device to transistor ON/OFF.
- Output current
Each point current is 0.15A to avoid over-heat.
- Open circuit leakage current
Below 0.1mA

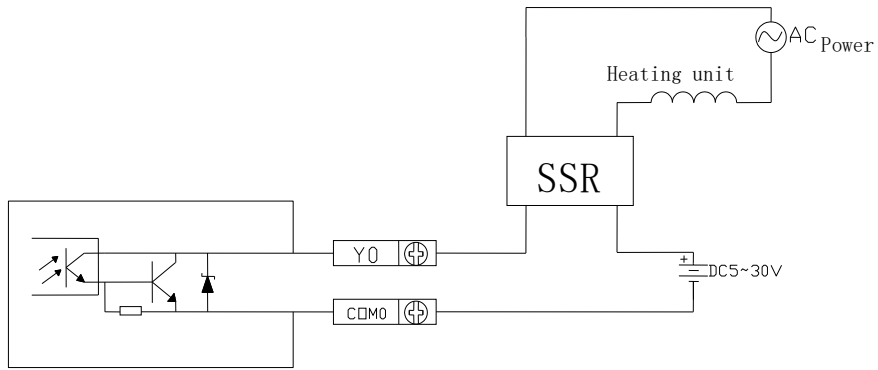

PT100 input features:

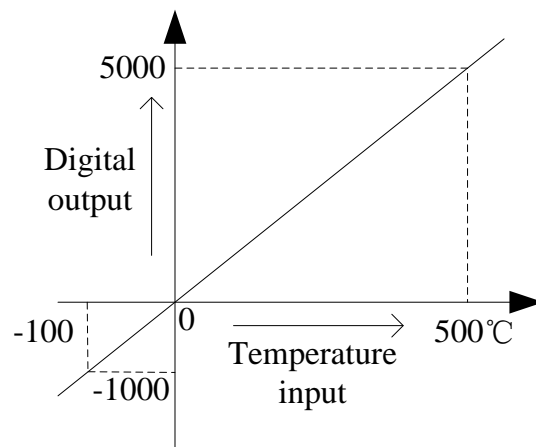

8-6. Programming

Example 1: Module 1, PID control for CH0

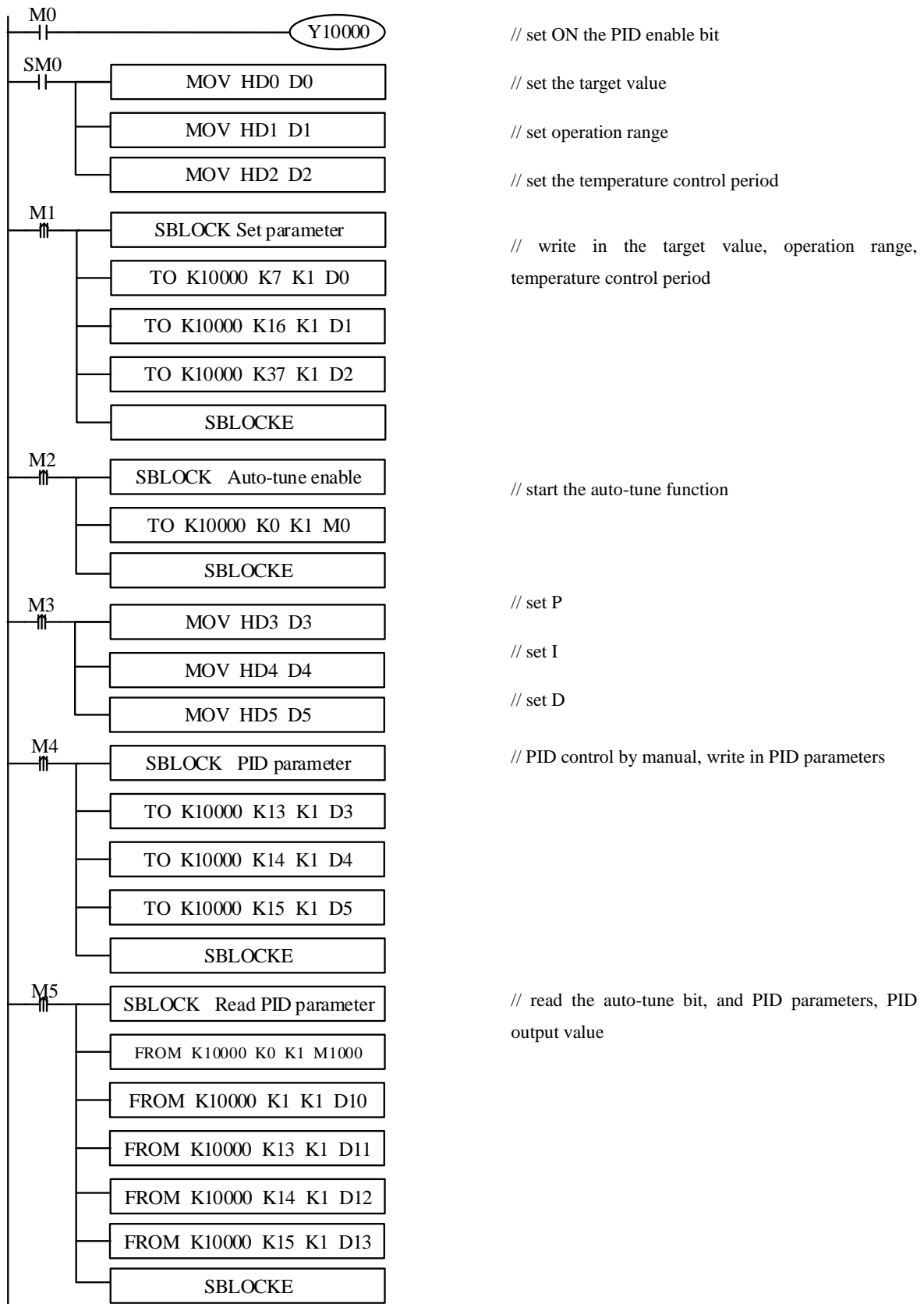

Explanation:

- M0 set ON PID enable bit
- SM0 set the target value, operation range, temperature control period
- M1 write in target value, operation range, temperature control period
- M2 start the auto-tune
- M3 set manual P, I, D parameters
- M4 write in manual P, I, D parameters
- M5 read auto-tune bit, PID parameters, PID output value

Y10000 channel 0 PID enable

- HD0 set target value
- HD1 operation range
- HD2 temperature control period
- HD3 P
- HD4 I
- HD5 D

9. K type thermocouple temperature control module XD-E6TC-P

9-1. Specification

XD-E6TC-P can process the thermocouple signal and send the data to the PLC.

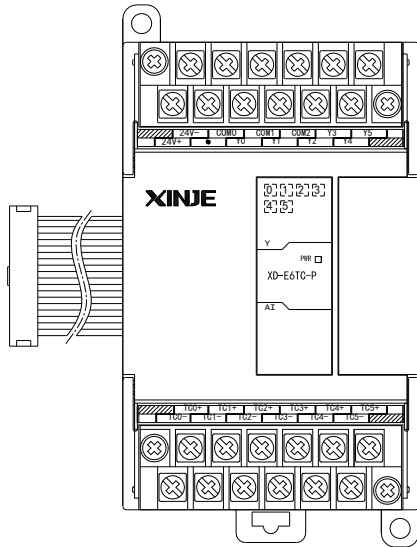

- thermocouple sensor signal input
- 6 channels input, 6 channels output
- 6 groups PID parameters, auto-tune function
- Built-in cold-terminal compensation circuit
- Resolution is 0.1°C
- As special function module of XD3, up to 10 modules can be connected to PLC (XDM PLC can connect 16 modules)

Items	Content
Analog input signal	K, S, E, N, B, T, J type thermocouple
Temperature measurement range	0°C~1000°C
Digital output range	0~10000, 16 bits with sign bit, binary
Control precision	±0.5°C
Resolution	0.1°C
Integrate precision	1% (relative max value)
Conversion speed	20ms per channel
Analog power	DC24V ±10%, 50mA
Install format	Fixed with M3 screws or directly installed on orbit of DIN46277 (Width: 35mm)
Dimension	63mm×108mm×79.9mm

Note:

1. If no signal input, the channel data is 0
2. According to the actual requirement to connect the thermocouple
3. The cover of device which installs thermocouple should be connected to the ground.

9-2. Terminals

	24V-	COM0	COM1	COM2	Y3	Y5
	24V+	●	Y0	Y1	Y2	Y4

	TC0+	TC1+	TC2+	TC3+	TC4+	TC5+
	TC0-	TC1-	TC2-	TC3-	TC4-	TC5-

Channel	Terminal name	Signal name
CH0	TC0+	0CH thermocouple input +
	TC0-	0CH thermocouple input -
CH1	TC1+	1CH thermocouple input +
	TC1-	1CH thermocouple input -
CH2	TC2+	2CH thermocouple input +
	TC2-	2CH thermocouple input -
CH3	TC3+	3CH thermocouple input +
	TC3-	3CH thermocouple input -
CH4	TC4+	4CH thermocouple input +
	TC4-	4CH thermocouple input -
CH5	TC5+	5CH thermocouple input +
	TC5-	5CH thermocouple input -
CH0	Y0	0CH output
	COM0	0CH common terminal of output
CH1	Y1	1CH output
	COM1	1CH common terminal of output
CH2	Y2	2CH output
	COM2	2CH common terminal of output
CH3	Y3	3CH output
	COM3	3CH common terminal of output
CH4	Y4	4CH output
	COM4	4CH common terminal of output
CH5	Y5	5CH output
	COM5	5CH common terminal of output
-	24V+	+24V power supply
	24V-	Common terminal of power supply

9-3. I/O address assignment

XD series analog module will not occupy I/O unit, the conversion value will be sent to PLC register. Each channel related PLC register address are shown as below:

Parameters	Explanation				
	Channel	Ch0	Ch1	Ch5
Display temperature Unit: 0.1 °C	Module 1	ID10000	ID10001	ID1000×	ID10005
	Module 2	ID10100	ID10101	ID10X0×	ID10105
	ID10X00	ID10X01	ID10X0×	ID10X05
	Module 16	ID11500	ID11501	ID1150×	ID11505
PID output (return to the X input of PLC)	Module 1	X10000	X10001	X1000×	X10005
	Module 2	X10100	X10101	X1010×	X10105
	X10×00	X10×01	X10×0×	X10×05
	Module 16	X11700	X11701	X1170×	X11705
Connection state of thermocouple(0 is connection, 1 is disconnection)	Module 1	X10010	X10011	X1001×	X10015
	Module 2	X10110	X10111	X1011×	X10115
	X10××0	X10××1	X10×××	X10××5
	Module 16	X11710	X11711	X1171×	X11715
Enable signal	Module 1	Y10000	Y10001	Y1000×	Y10005
	Module 2	Y10100	Y10101	Y1010×	Y10105
	Y1××00	Y1××01	Y1××0×	Y1××05
	Module 16	Y11700	Y11701	Y1170×	Y11705
PID auto-tune error signal bit(0 is normal, 1 is error)	Module 1	X10020	X10021	X1002X	X10025
	Module 2	X10120	X10121	X1012×	X10125
	X1××20	X1××21	X1××2×	X1××25
	Module 16	X11720	X11721	X1172×	X11725
PID control bit	Auto-tune triggered signal, start to auto-tune mode when set to 1 After auto-tune, PID parameters and temperature control period value are refreshed, the bit value is cleared to be 0. The user can read the bit to know the state. 1 means auto-tune is ongoing. 0 means auto-tune has finished.				
PID output (The result)	Digital quantity output range is 0~4095. When the PID output is analog quantity (such as steam valve open degree or silicon-controlled conduction angle), the value can be transmitted to the analog quantity output module in order to realize the control demand.				
PID parameters (P, I, D)	The best PID parameters got from the PID auto-tune. If the current PID parameters cannot meet the control requirements, users can set the experience PID parameters to make the module work according to the user setting value.				
PID calculation range (Diff) Unit: 0.1°C	PID arithmetic is effective in the range of T (setting temperature) ±Diff. In real temperature control environment, when the temperature is lower than T- Diff, the PID output is the maximum value; when the temperature is higher than T+Diff, the PID output is the minimum value.				

Temperature difference value δ Unit: 0.1°C	(sampling temperature value + temperature difference value δ) / 10 = display temperature. At the time the display temperature is the most close to the real temperature. This parameter is a sign value with the unit of 0.1°C, the value is retained when th power is cut off, the defaulted value is 0.
Set temperature Unit: 0.1°C	The target temperature of the control system. Range from 0~1000°C, precision degree is 0.1°C.
Temperature control period Unit: 0.1s	The temperature control period range from 0.5 to 200 seconds, the minimum precision is 0.1 second. The set value = real value \times 10. For example: if the real temperature control period is 0.5 seconds, user should set 5 seconds in the module.
Adjusting environment temperature Unit: 0.1°C	If user realizes that the environment temperature is different from display temperature, they can write the correct environment temperature into the module. Then the module will calculate the temperature difference δ and save it. Temperature difference δ = adjusting environment temperature – sampling temperature. Unit: 0.1°C. For example, under the caloric balance condition, users measured the environment temperature is 60°C with mercury thermometer, but the display temperature is 55°C (sampling temperature is 550), temperature difference δ is 50. At this time, users can set the parameter to be 600, then the temperature difference δ is 50 (5 °C). Display temperature = (550 + 50) / 10 = 60 °C. **Attention: when setting the adjusting environment temperature, make sure it is the same as environment temperature. It is very important because the incorrect parameter will result in mistake of calculating temperature difference δ and affect the display temperature.
auto-tune output range	The auto-tune output unit is percent. 100 means the duty ratio is 100% of the full-scale output, 80 means the duty ratio is 80% of the full-scale output.

FROM and TO instructions

(3) Parameter write insruction TO

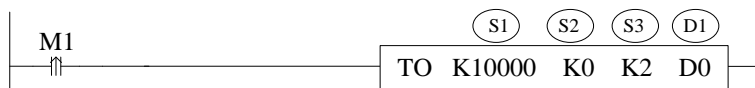

Function: write the PLC register data to module address, the operate unit is word.

Operand:

S1: target module number, range: 10000~10015. Operand: K, TD, CD, D, HD, FD

S2: first address of module. Operand: K, TD, CD, D, HD, FD

S3: write in register numbers. Operand: K, TD, CD, D, HD, FD

D1: first address of PLC. Operand: TD, CD, D, HD, FD

(4) Parameter read instruction FROM



Function: read the module data to the PLC regsiter, the operate unit is word.

S1: target module number, range: 10000~10015. Operand: K, TD, CD, D, HD, FD

S2: first address of module. Operand: K, TD, CD, D, HD, FD

S3: read register numbers. Operand: K, TD, CD, D, HD, FD

D1: first address of PLC. Operand: TD, CD, D, HD, FD

Note:

3. FROM and TO only can be programmed in the sequence block, one program only supports 8 sequence blocks.
4. The module number range is 0 to 15 for the software version v3.3 and below.

Related address definition:

The address of the read/write parameters:

From_To data	CH1	CH2	CH3	CH4	CH5	CH6	R/W	
Auto-tune enable	K0	K0	K0	K0	K0	K0	RW	
PID output	K1	K2	K3	K4	K5	K6	R	
Setting	K7	K8	K9	K10	K11	K12	RW	
PID	Kp	K13	K17	K21	K25	K29	K33	RW
	Ki	K14	K18	K22	K26	K30	K34	RW
	Kd	K15	K19	K23	K27	K31	K35	RW
	Diff	K16	K20	K24	K28	K32	K36	RW
Temperature control period (unit: 0.1s)	K37	K38	K39	K40	K41	K42	RW	
Output range (0~100)	K43	K44	K45	K46	K47	K48	RW	
Temperature deviation calibration	K49	K50	K51	K52	K53	K54	RW	
Present actual temperature, can be used to calibrate	K55	K56	K57	K58	K59	K60	W	

Besides, the module can save the setting temperature, PID parameters, temperature difference value, temperature control period, auto-tune output range, etc. The parameters will be saved after auto-tune or user modification, and be operated after re-power on.

Module 1			Module 2		
Channel	Present temperature	PID start/stop bit	Channe	Present temperature	PID start/stop bit
0CH	ID10000	Y10000	0CH	ID10100	Y10100
1CH	ID10001	Y10001	1CH	ID10101	Y10101
2CH	ID10002	Y10002	2CH	ID10102	Y10102
3CH	ID10003	Y10003	3CH	ID10103	Y10103
4CH	ID10004	Y10004	4CH	ID10104	Y10104
5CH	ID10005	Y10005	5CH	ID10105	Y10105

Module 3			Module 4		
Channel	Present temperature	PID start/stop bit	Channel	Present temperature	PID start/stop bit
0CH	ID10200	Y10200	0CH	ID10300	Y10300

1CH	ID10201	Y10201	1CH	ID10301	Y10301
2CH	ID10202	Y10202	2CH	ID10302	Y10302
3CH	ID10203	Y10203	3CH	ID10303	Y10303
4CH	ID10204	Y10204	4CH	ID10304	Y10304
5CH	ID10205	Y10205	5CH	ID10305	Y10305

Module 5			Module 6		
Channel	Present temperature	PID start/stop bit	Channel	Present temperature	PID start/stop bit
0CH	ID10400	Y10400	0CH	ID10500	Y10500
1CH	ID10401	Y10401	1CH	ID10501	Y10501
2CH	ID10402	Y10402	2CH	ID10502	Y10502
3CH	ID10403	Y10403	3CH	ID10503	Y10503
4CH	ID10404	Y10404	4CH	ID10504	Y10504
5CH	ID10405	Y10405	5CH	ID10505	Y10505

Module 7			Module 8		
Channel	Present temperature	PID start/stop bit	Channel	Present temperature	PID start/stop bit
0CH	ID10600	Y10600	0CH	ID10700	Y10700
1CH	ID10601	Y10601	1CH	ID10701	Y10701
2CH	ID10602	Y10602	2CH	ID10702	Y10702
3CH	ID10603	Y10603	3CH	ID10703	Y10703
4CH	ID10604	Y10604	4CH	ID10704	Y10704
5CH	ID10605	Y10605	5CH	ID10705	Y10705

Module 9			Module 10		
Channel	Present temperature	PID start/stop bit	Channel	Present temperature	PID start/stop bit
0CH	ID10800	Y11000	0CH	ID10900	Y11100
1CH	ID10801	Y11001	1CH	ID10901	Y11101
2CH	ID10802	Y11002	2CH	ID10902	Y11102
3CH	ID10803	Y11003	3CH	ID10903	Y11103
4CH	ID10804	Y11004	4CH	ID10904	Y11104
5CH	ID10805	Y11005	5CH	ID10905	Y11105

Module 11			Module 12		
Channel	Present temperature	PID start/stop bit	Channel	Present temperature	PID start/stop bit
0CH	ID11000	Y11200	0CH	ID11100	Y11300
1CH	ID11001	Y11201	1CH	ID11101	Y11301

2CH	ID11002	Y11202	2CH	ID11102	Y11302
3CH	ID11003	Y11203	3CH	ID11103	Y11303
4CH	ID11004	Y11204	4CH	ID11104	Y11304
5CH	ID11005	Y11205	5CH	ID11105	Y11305

Module 13			Module 14		
Channel	Present temperature	PID start/stop bit	Channel	Present temperature	PID start/stop bit
0CH	ID11200	Y11400	0CH	ID11300	Y11500
1CH	ID11201	Y11401	1CH	ID11301	Y11501
2CH	ID11202	Y11402	2CH	ID11302	Y11502
3CH	ID11203	Y11403	3CH	ID11303	Y11503
4CH	ID11204	Y11404	4CH	ID11304	Y11504
5CH	ID11205	Y11405	5CH	ID11305	Y11505

Module 15			Module 16		
Channel	Present temperature	PID start/stop bit	Channel	Present temperature	PID start/stop bit
0CH	ID11400	Y11600	0CH	ID11500	Y11700
1CH	ID11401	Y11601	1CH	ID11501	Y11701
2CH	ID11402	Y11602	2CH	ID11502	Y11702
3CH	ID11403	Y11603	3CH	ID11503	Y11703
4CH	ID11404	Y11604	4CH	ID11504	Y11704
5CH	ID11405	Y11605	5CH	ID11505	Y11705

Description:

Start signal (Y): When Y is 0, close PID control; when Y is 1, start PID control.

9-4. Working mode

There are two ways to set the working mode:

1. XDPpro software
2. Flash registers of PLC

XDPpro software:

Open the XDPpro software, click configure/expansion module settings:

Set the model and channel parameters in the following window. Then click write to PLC.

Please restart the PLC after setting.

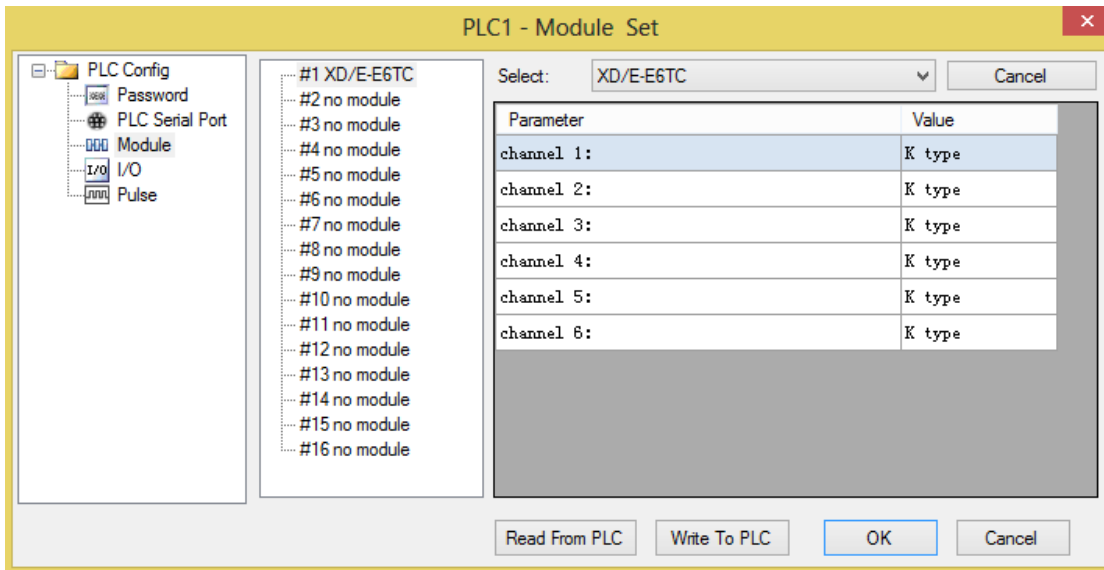

Flash registers:

Set the filter time and control cycle through SFD registers of PLC:

Module no.	SFD address	Module no.	SFD address
#1	SFD350~SFD359	#9	SFD430~SFD439
#2	SFD360~SFD369	#10	SFD440~SFD449
#3	SFD370~SFD379	#11	SFD450~SFD459
#4	SFD380~SFD389	#12	SFD460~SFD469
#5	SFD390~SFD399	#13	SFD470~SFD479
#6	SFD400~SFD409	#14	SFD480~SFD489
#7	SFD410~SFD419	#15	SFD490~SFD499
#8	SFD420~SFD429	#16	SFD500~SFD509

SFD bit definition:

Filter mode and control cycle:

The module can set two working modes: filter mode and control cycle.

Control cycle: when the module is doing PID control, the output terminal will control the heating process in

certain period according to duty ratio calculated from PID output value. The certain period is control cycle.

Expansion module no.1 setting:

	Bit7	Bit6	Bit5	Bit4	Bit3	Bit2	Bit1	Bit0	Explanation
Byte0	AD channel 2, channel 1 filter time								AD filter time
Byte1	AD channel 4, channel 3 filter time								
Byte2	AD channel 6, channel 5 filter time								
Byte3~Byte19	Reserved								

9-5. Exterior connection

About the exterior connection, please pay attention to the following items:

- When connect to +24V power, please use the 24V power supply of PLC to avoid interference.
- To avoid interference, shielding measure is necessary for signal cables.

Input connection:

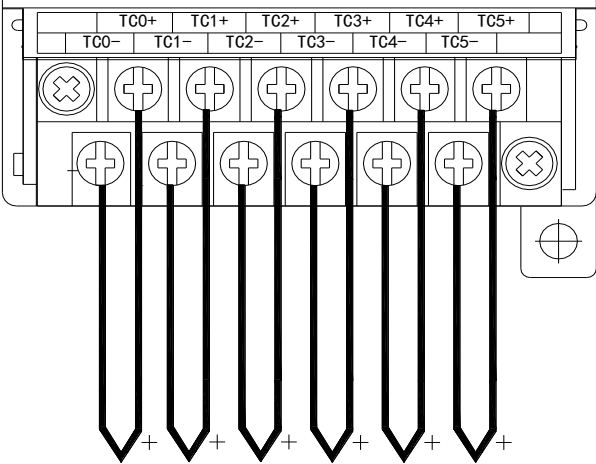

Output circuit:

- Output terminal
For transistor output terminals, please use DC5V~30V power supply.
- Circuit insulation
PLC internal circuit and output transistor is optical insulation with optical coupling device. Each public module is separate.
- Response time
The time is less than 0.2ms from PLC driving (or cut) optical coupling circuit to transistor ON/OFF.
- Output circuit
Each point current is 0.15A to avoid over-heating.

- Open circuit leak current
Below 0.1mA.

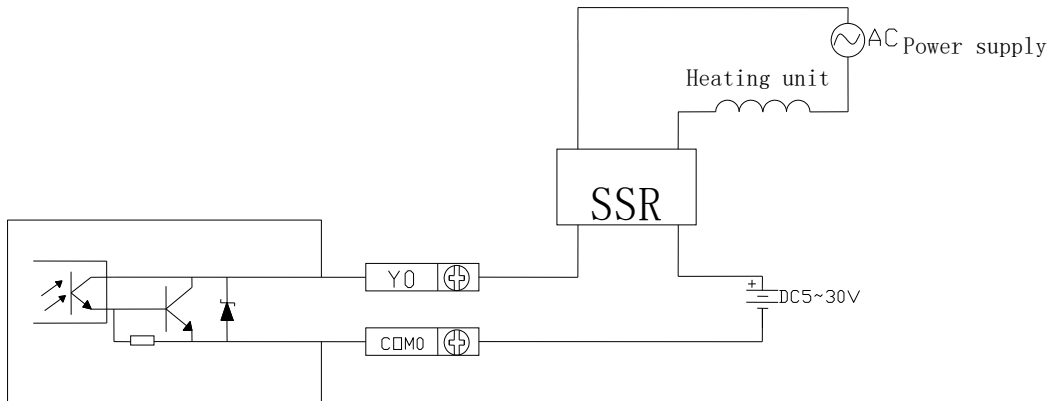

9-6. Programming

Example: programming for the first channel.

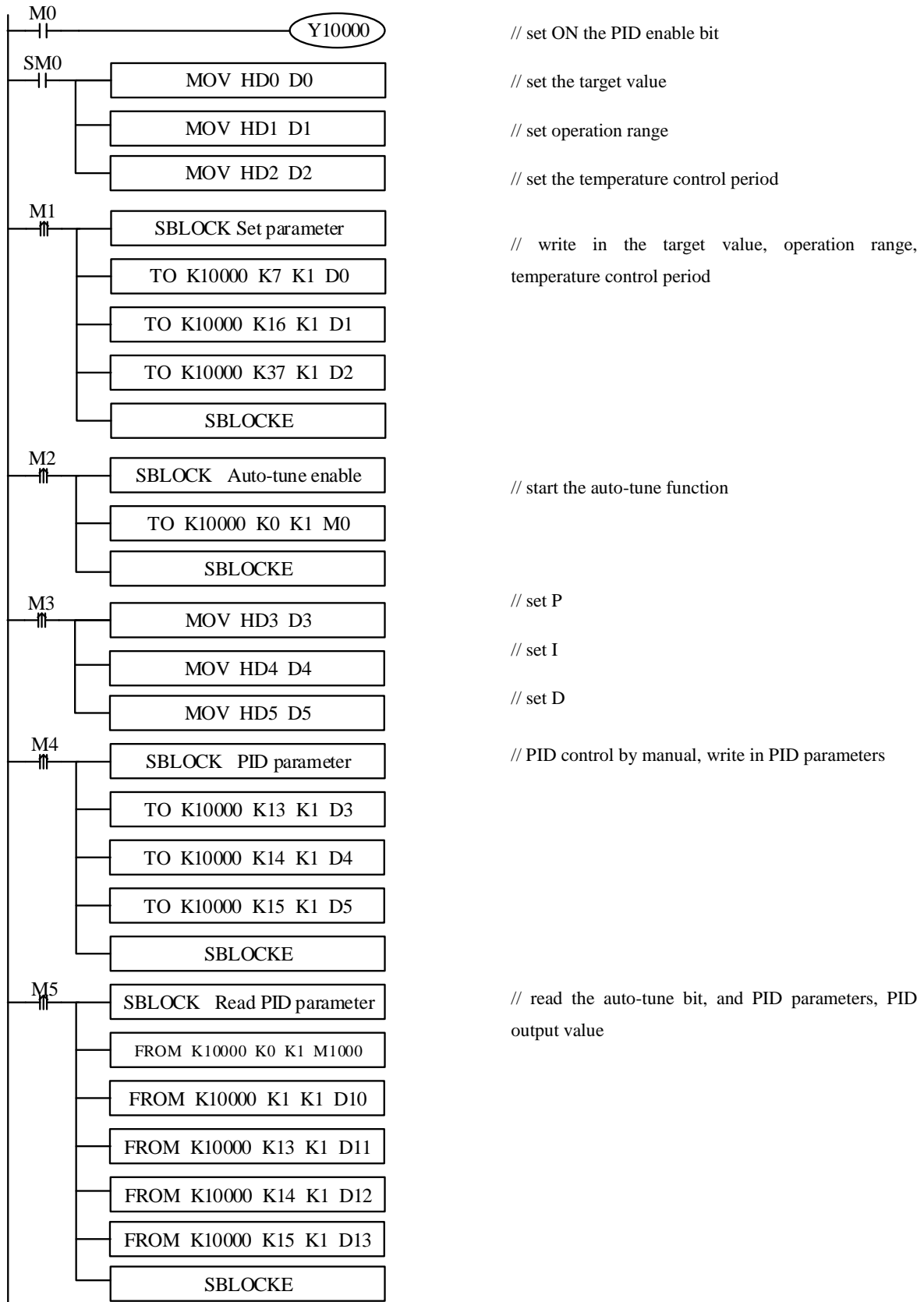

Explanation:

- M0 set ON PID enable bit
- SM0 set the target value, operation range, temperature control period
- M1 write in target value, operation range, temperature control period
- M2 start the auto-tune
- M3 set manual P, I, D parameters
- M4 write in manual P, I, D parameters
- M5 read auto-tune bit, PID parameters, PID output value

Y10000 channel 0 PID enable

- HD0 set target value
- HD1 operation range
- HD2 temperature control period
- HD3 P
- HD4 I
- HD5 D

10. I/O expansion module XD-EnXmY

10-1. Specifications

XD-EnXmY is the extension module of XD series, up to 10 XD-EnXmY modules can be connected to XD3 series PLC(up to 16 modules for XDM series PLC) . This module has rich types, small size, and more I/O points which can meet more requirements.

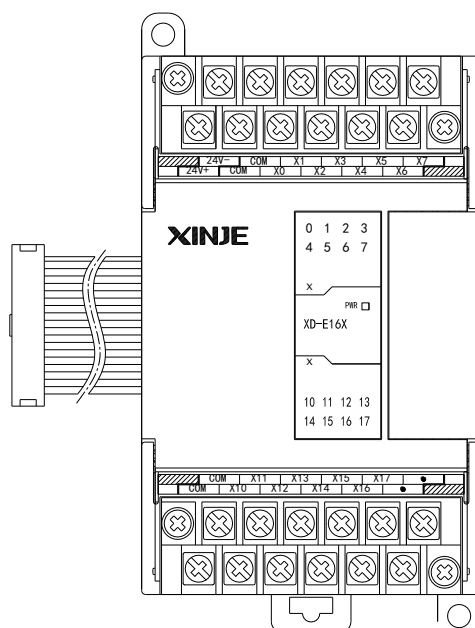

Module types

Model		Function
NPN input	PNP input	
XD-E8X	XD-E8PX	8 channels digital input
XD-E8YR	-	8 channels relay output
XD-E8YT	-	8 channels transistor output
XD-E8X8YR	XD-E8PX8YR	8 channels digital input, 8 channels relay output
XD-E8X8YT	XD-E8PX8YT	8 channels digital input, 8 channels transistor output
XD-E16X	XD-E16PX	16 channels digital input
XD-E16YR	-	16 channels relay output
XD-E16YT	-	16 channels transistor output
XD-E16X16YR-E	XD-E16PX16YR-E	16 channels digital input, 16 channels relay output, AC220V
XD-E16X16YR-C	XD-E16PX16YR-C	16 channels digital input, 16 channels relay output, DC24V
XD-E16X16YT-E	XD-E16PX16YT-E	16 channels digital input, 16 channels transistor output, AC220V
XD-E16X16YT-C	XD-E16PX16YT-C	16 channels digital input, 16 channels transistor output, DC24V
XD-E32YR-E	-	32 channels relay output, AC220V
XD-E32YR-C	-	32 channels relay output, DC24V
XD-E32YT-E	-	32 channels transistor output, AC220V
XD-E32YT-C	-	32 channels transistor output, DC24V
XD-E32X-E	XD-E32PX-E	32 channels digital input, AC220V
XD-E32X-C	XD-E32PX-C	32 channels digital input, DC24V

Module Specifications

Items	Specifications
Input voltage (Power supply)	DC24V \pm 10% (32 points module is AC220V \pm 10%)
Application environment	No corrosive gas
Environment temperature	0°C~60°C
Environment humidity	5~95%
Installation	Fixed with M3 screws or directly installed on DIN46277 rail (Width: 35mm)
Dimension	8~16 points module: 63mm \times 108mm \times 79.9mm 32 points module: 139mm \times 110mm \times 73.3mm

10-2. Terminals

The terminals distributions of NPN and PNP input are the same.

- (1) XD-E8X

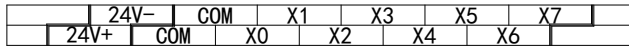

(2) XD-E8YR, XD-E8YT

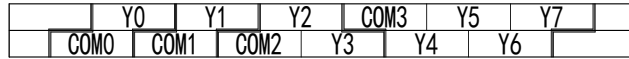

(3) XD-E8X8YR, XD-E8X8YT

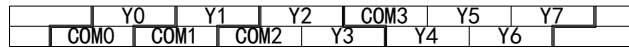
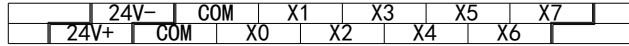

(4) XD-E16X

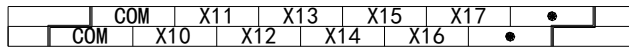
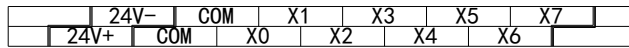

(5) XD-E16YR, XD-E16YT

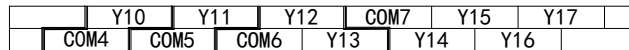
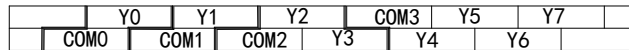

(6) XD-E16X16YR/T-E

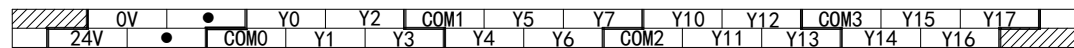
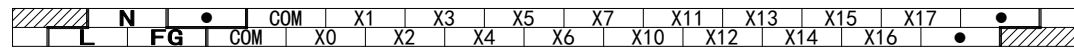

(7) XD-E16X16YR/T-C

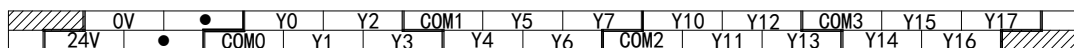
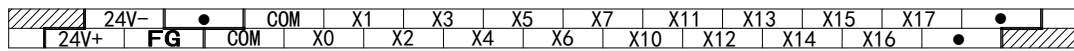

(8) XD-E32YR/T-E

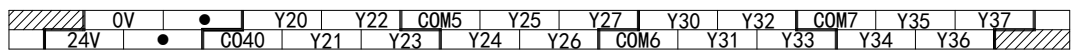
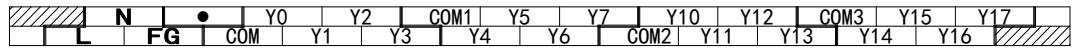

(9) XD-E32YR/T-C

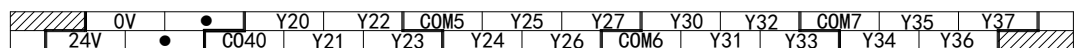
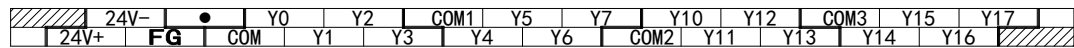

(10) XD-E32X-E

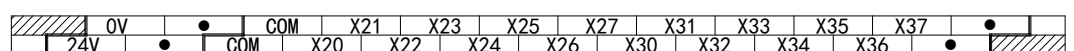
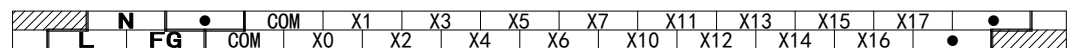

(11) XD-E32X-C

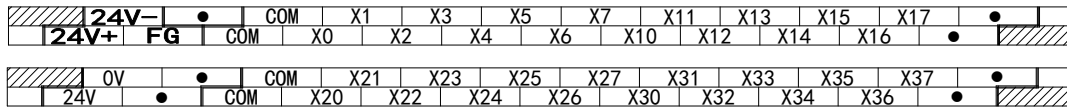

Caution: Maybe the common terminal of each module is different from above pictures; please see the label of actual objects.

10-3. I/O address assignment

XD3 series can expand 10 modules, the address of I/O terminals are shown as below:
 (Caution: Take NPN type as an example, the terminals definition, address, suitable module of PNP are the same as NPN)

- **XD-E8X8YR, XD-E8X8YT**

Expansion module no.1 to no.16 terminal address:

	X0	X1	X2	X3	X4	X5	X6	X7
Expansion module no.1	X10000	X10001	X10002	X10003	X10004	X10005	X10006	X10007
Expansion module no.2	X10100	X10101	X10102	X10103	X10104	X10105	X10106	X10107
Expansion module no.3	X10200	X10201	X10202	X10203	X10204	X10205	X10206	X10207
Expansion module no.4	X10300	X10301	X10302	X10303	X10304	X10305	X10306	X10307
Expansion module no.5	X10400	X10401	X10402	X10403	X10404	X10405	X10406	X10407
Expansion module no.6	X10500	X10501	X10502	X10503	X10504	X10505	X10506	X10507
Expansion module no.7	X10600	X10601	X10602	X10603	X10604	X10605	X10606	X10607
Expansion module no.8	X10700	X10701	X10702	X10703	X10704	X10705	X10706	X10707
Expansion module no.9	X11000	X11001	X11002	X11003	X11004	X11005	X11006	X11007
Expansion module no.10	X11100	X11101	X11102	X11103	X11104	X11105	X11106	X11107
Expansion module no.11	X11200	X11201	X11202	X11203	X11204	X11205	X11206	X11207
Expansion module no.12	X11300	X11301	X11302	X11303	X11304	X11305	X11306	X11307
Expansion module no.13	X11400	X11401	X11402	X11403	X11404	X11405	X11406	X11407
Expansion module no.14	X11500	X11501	X11502	X11503	X11504	X11505	X11506	X11507
Expansion module no.15	X11600	X11601	X11602	X11603	X11604	X11605	X11606	X11607
Expansion module no.16	X11700	X11701	X11702	X11703	X11704	X11705	X11706	X11707

	Y0	Y1	Y2	Y3	Y4	Y5	Y6	Y7
Expansion module no.1	Y10000	Y10001	Y10002	Y10003	Y10004	Y10005	Y10006	Y10007
Expansion module no.2	Y10100	Y10101	Y10102	Y10103	Y10104	Y10105	Y10106	Y10107
Expansion module no.3	Y10200	Y10201	Y10202	Y10203	Y10204	Y10205	Y10206	Y10207
Expansion module no.4	Y10300	Y10301	Y10302	Y10303	Y10304	Y10305	Y10306	Y10307
Expansion module no.5	Y10400	Y10401	Y10402	Y10403	Y10404	Y10405	Y10406	Y10407

Expansion module no.6	Y10500	Y10501	Y10502	Y10503	Y10504	Y10505	Y10506	Y10507
Expansion module no.7	Y10600	Y10601	Y10602	Y10603	Y10604	Y10605	Y10606	Y10607
Expansion module no.8	Y10700	Y10701	Y10702	Y10703	Y10704	Y10705	Y10706	Y10707
Expansion module no.9	Y11000	Y11001	Y11002	Y11003	Y11004	Y11005	Y11006	Y11007
Expansion module no.10	Y11100	Y11101	Y11102	Y11103	Y11104	Y11105	Y11106	Y11107
Expansion module no.11	Y11200	Y11201	Y11202	Y11203	Y11204	Y11205	Y11206	Y11207
Expansion module no.12	Y11300	Y11301	Y11302	Y11303	Y11304	Y11305	Y11306	Y11307
Expansion module no.13	Y11400	Y11401	Y11402	Y11403	Y11404	Y11405	Y11406	Y11407
Expansion module no.14	Y11500	Y11501	Y11502	Y11503	Y11504	Y11505	Y11506	Y11507
Expansion module no.15	Y11600	Y11601	Y11602	Y11603	Y11604	Y11605	Y11606	Y11607
Expansion module no.16	Y11700	Y11701	Y11702	Y11703	Y11704	Y11705	Y11706	Y11707

- **XD-E8X**

Expansion module no.1 to no.16 terminal address:

	X0	X1	X2	X3	X4	X5	X6	X7
Expansion module no.1	X10000	X10001	X10002	X10003	X10004	X10005	X10006	X10007
Expansion module no.2	X10100	X10101	X10102	X10103	X10104	X10105	X10106	X10107
Expansion module no.3	X10200	X10201	X10202	X10203	X10204	X10205	X10206	X10207
Expansion module no.4	X10300	X10301	X10302	X10303	X10304	X10305	X10306	X10307
Expansion module no.5	X10400	X10401	X10402	X10403	X10404	X10405	X10406	X10407
Expansion module no.6	X10500	X10501	X10502	X10503	X10504	X10505	X10506	X10507
Expansion module no.7	X10600	X10601	X10602	X10603	X10604	X10605	X10606	X10607
Expansion module no.8	X10700	X10701	X10702	X10703	X10704	X10705	X10706	X10707
Expansion module no.9	X11000	X11001	X11002	X11003	X11004	X11005	X11006	X11007
Expansion module no.10	X11100	X11101	X11102	X11103	X11104	X11105	X11106	X11107
Expansion module no.11	X11200	X11201	X11202	X11203	X11204	X11205	X11206	X11207
Expansion module no.12	X11300	X11301	X11302	X11303	X11304	X11305	X11306	X11307
Expansion module no.13	X11400	X11401	X11402	X11403	X11404	X11405	X11406	X11407
Expansion module no.14	X11500	X11501	X11502	X11503	X11504	X11505	X11506	X11507
Expansion module no.15	X11600	X11601	X11602	X11603	X11604	X11605	X11606	X11607
Expansion module no.16	X11700	X11701	X11702	X11703	X11704	X11705	X11706	X11707

- **XD-E8YR, XD-E8YT**

Expansion module no.1 to no.16 terminal address:

	Y0	Y1	Y2	Y3	Y4	Y5	Y6	Y7
Expansion module no.1	Y10000	Y10001	Y10002	Y10003	Y10004	Y10005	Y10006	Y10007
Expansion module no.2	Y10100	Y10101	Y10102	Y10103	Y10104	Y10105	Y10106	Y10107
Expansion module no.3	Y10200	Y10201	Y10202	Y10203	Y10204	Y10205	Y10206	Y10207
Expansion module no.4	Y10300	Y10301	Y10302	Y10303	Y10304	Y10305	Y10306	Y10307
Expansion module no.5	Y10400	Y10401	Y10402	Y10403	Y10404	Y10405	Y10406	Y10407
Expansion module no.6	Y10500	Y10501	Y10502	Y10503	Y10504	Y10505	Y10506	Y10507
Expansion module no.7	Y10600	Y10601	Y10602	Y10603	Y10604	Y10605	Y10606	Y10607
Expansion module no.8	Y10700	Y10701	Y10702	Y10703	Y10704	Y10705	Y10706	Y10707
Expansion module no.9	Y11000	Y11001	Y11002	Y11003	Y11004	Y11005	Y11006	Y11007
Expansion module no.10	Y11100	Y11101	Y11102	Y11103	Y11104	Y11105	Y11106	Y11107
Expansion module no.11	Y11200	Y11201	Y11202	Y11203	Y11204	Y11205	Y11206	Y11207
Expansion module no.12	Y11300	Y11301	Y11302	Y11303	Y11304	Y11305	Y11306	Y11307
Expansion module no.13	Y11400	Y11401	Y11402	Y11403	Y11404	Y11405	Y11406	Y11407
Expansion module no.14	Y11500	Y11501	Y11502	Y11503	Y11504	Y11505	Y11506	Y11507
Expansion module no.15	Y11600	Y11601	Y11602	Y11603	Y11604	Y11605	Y11606	Y11607
Expansion module no.16	Y11700	Y11701	Y11702	Y11703	Y11704	Y11705	Y11706	Y11707

● **XD-E16X**

Expansion module no.1 to no.16 input terminal address:

	Expansion module no.1	Expansion module no.2	Expansion module no.3	Expansion module no.4	Expansion module no.5	Expansion module no.6	Expansion module no.7	Expansion module no.8	Expansion module no.9	Expansion module no.10
X0	X10000	X10100	X10200	X10300	X10400	X10500	X10600	X10700	X11000	X11100
X1	X10001	X10101	X10201	X10301	X10401	X10501	X10601	X10701	X11001	X11101
X2	X10002	X10102	X10202	X10302	X10402	X10502	X10602	X10702	X11002	X11102
X3	X10003	X10103	X10203	X10303	X10403	X10503	X10603	X10703	X11003	X11103
X4	X10004	X10104	X10204	X10304	X10404	X10504	X10604	X10704	X11004	X11104
X5	X10005	X10105	X10205	X10305	X10405	X10505	X10605	X10705	X11005	X11105
X6	X10006	X10106	X10206	X10306	X10406	X10506	X10606	X10706	X11006	X11106
X7	X10007	X10107	X10207	X10307	X10407	X10507	X10607	X10707	X11007	X11107
X10	X10010	X10110	X10210	X10310	X10410	X10510	X10610	X10710	X11010	X11110
X11	X10011	X10111	X10211	X10311	X10411	X10511	X10611	X10711	X11011	X11111
X12	X10012	X10112	X10212	X10312	X10412	X10512	X10612	X10712	X11012	X11112
X13	X10013	X10113	X10213	X10313	X10413	X10513	X10613	X10713	X11013	X11113
X14	X10014	X10114	X10214	X10314	X10414	X10514	X10614	X10714	X11014	X11114

X15	X10015	X10115	X10215	X10315	X10415	X10515	X10615	X10715	X11015	X11115
X16	X10016	X10116	X10216	X10316	X10416	X10516	X10616	X10716	X11016	X11116
X17	X10017	X10117	X10217	X10317	X10417	X10517	X10617	X10717	X11017	X11117
	Expansion module no.11	Expansion module no.12	Expansion module no.13	Expansion module no.14	Expansion module no.15	Expansion module no.16				
X0	X11200	X11300	X11400	X11500	X11600	X11700				
X1	X11201	X11301	X11401	X11501	X11600	X11701				
X2	X11202	X11302	X11402	X11502	X11602	X11702				
X3	X11203	X11303	X11403	X11503	X11603	X11703				
X4	X11204	X11304	X11404	X11504	X11604	X11704				
X5	X11205	X11305	X11405	X11505	X11605	X11705				
X6	X11206	X11306	X11406	X11506	X11606	X11706				
X7	X11207	X11307	X11407	X11507	X11607	X11707				
X10	X11210	X11310	X11410	X11510	X11610	X11710				
X11	X11211	X11311	X11411	X11511	X11611	X11711				
X12	X11212	X11312	X11412	X11512	X11612	X11712				
X13	X11213	X11313	X11413	X11513	X11613	X11713				
X14	X11214	X11314	X11414	X11514	X11614	X11714				
X15	X11215	X11315	X11415	X11515	X11615	X11715				
X16	X11216	X11316	X11416	X11516	X11616	X11716				
X17	X11217	X11317	X11417	X11517	X11617	X11717				

● **XD-E16Y**

Expansion module no.1 to no.16 input terminal address:

	Expansion module no.1	Expansion module no.2	Expansion module no.3	Expansion module no.4	Expansion module no.5	Expansion module no.6	Expansion module no.7	Expansion module no.8	Expansion module no.9	Expansion module no.10
Y0	Y10000	Y10100	Y10200	Y10300	Y10400	Y10500	Y10600	Y10700	Y11000	Y11100
Y1	Y10001	Y10101	Y10201	Y10301	Y10401	Y10501	Y10601	Y10701	Y11001	Y11101
Y2	Y10002	Y10102	Y10202	Y10302	Y10402	Y10502	Y10602	Y10702	Y11002	Y11102
Y3	Y10003	Y10103	Y10203	Y10303	Y10403	Y10503	Y10603	Y10703	Y11003	Y11103
Y4	Y10004	Y10104	Y10204	Y10304	Y10404	Y10504	Y10604	Y10704	Y11004	Y11104
Y5	Y10005	Y10105	Y10205	Y10305	Y10405	Y10505	Y10605	Y10705	Y11005	Y11105
Y6	Y10006	Y10106	Y10206	Y10306	Y10406	Y10506	Y10606	Y10706	Y11006	Y11106
Y7	Y10007	Y10107	Y10207	Y10307	Y10407	Y10507	Y10607	Y10707	Y11007	Y11107
Y10	Y10010	Y10110	Y10210	Y10310	Y10410	Y10510	Y10610	Y10710	Y11010	Y11110
Y11	Y10011	Y10111	Y10211	Y10311	Y10411	Y10511	Y10611	Y10711	Y11011	Y11111
Y12	Y10012	Y10112	Y10212	Y10312	Y10412	Y10512	Y10612	Y10712	Y11012	Y11112

Y13	Y10013	Y10113	Y10213	Y10313	Y10413	Y10513	Y10613	Y10713	Y11013	Y11113
Y14	Y10014	Y10114	Y10214	Y10314	Y10414	Y10514	Y10614	Y10714	Y11014	Y11114
Y15	Y10015	Y10115	Y10215	Y10315	Y10415	Y10515	Y10615	Y10715	Y11015	Y11115
Y16	Y10016	Y10116	Y10216	Y10316	Y10416	Y10516	Y10616	Y10716	Y11016	Y11116
Y17	Y10017	Y10117	Y10217	Y10317	Y10417	Y10517	Y10617	Y10717	Y11017	Y11117
	Expansion module no.11	Expansion module no.12	Expansion module no.13	Expansion module no.14	Expansion module no.15	Expansion module no.16				
Y0	Y11200	Y11300	Y11400	Y11500	Y11600	Y11700				
Y1	Y11201	Y11301	Y11401	Y11501	Y11600	Y11701				
Y2	Y11202	Y11302	Y11402	Y11502	Y11602	Y11702				
Y3	Y11203	Y11303	Y11403	Y11503	Y11603	Y11703				
Y4	Y11204	Y11304	Y11404	Y11504	Y11604	Y11704				
Y5	Y11205	Y11305	Y11405	Y11505	Y11605	Y11705				
Y6	Y11206	Y11306	Y11406	Y11506	Y11606	Y11706				
Y7	Y11207	Y11307	Y11407	Y11507	Y11607	Y11707				
Y10	Y11210	Y11310	Y11410	Y11510	Y11610	Y11710				
Y11	Y11211	Y11311	Y11411	Y11511	Y11611	Y11711				
Y12	Y11212	Y11312	Y11412	Y11512	Y11612	Y11712				
Y13	Y11213	Y11313	Y11413	Y11513	Y11613	Y11713				
Y14	Y11214	Y11314	Y11414	Y11514	Y11614	Y11714				
Y15	Y11215	Y11315	Y11415	Y11515	Y11615	Y11715				
Y16	Y11216	Y11316	Y11416	Y11516	Y11616	Y11716				
Y17	Y11217	Y11317	Y11417	Y11517	Y11617	Y11717				

● **XD-E16X16Y**

Expansion module no.1 to no.16 input terminal address:

	Expansion module no.1	Expansion module no.2	Expansion module no.3	Expansion module no.4	Expansion module no.5	Expansion module no.6	Expansion module no.7	Expansion module no.8	Expansion module no.9	Expansion module no.10
X0	X10000	X10100	X10200	X10300	X10400	X10500	X10600	X10700	X11000	X11100
X1	X10001	X10101	X10201	X10301	X10401	X10501	X10601	X10701	X11001	X11101
X2	X10002	X10102	X10202	X10302	X10402	X10502	X10602	X10702	X11002	X11102
X3	X10003	X10103	X10203	X10303	X10403	X10503	X10603	X10703	X11003	X11103
X4	X10004	X10104	X10204	X10304	X10404	X10504	X10604	X10704	X11004	X11104
X5	X10005	X10105	X10205	X10305	X10405	X10505	X10605	X10705	X11005	X11105
X6	X10006	X10106	X10206	X10306	X10406	X10506	X10606	X10706	X11006	X11106
X7	X10007	X10107	X10207	X10307	X10407	X10507	X10607	X10707	X11007	X11107
X10	X10010	X10110	X10210	X10310	X10410	X10510	X10610	X10710	X11010	X11110

X11	X10011	X10111	X10211	X10311	X10411	X10511	X10611	X10711	X11011	X11111
X12	X10012	X10112	X10212	X10312	X10412	X10512	X10612	X10712	X11012	X11112
X13	X10013	X10113	X10213	X10313	X10413	X10513	X10613	X10713	X11013	X11113
X14	X10014	X10114	X10214	X10314	X10414	X10514	X10614	X10714	X11014	X11114
X15	X10015	X10115	X10215	X10315	X10415	X10515	X10615	X10715	X11015	X11115
X16	X10016	X10116	X10216	X10316	X10416	X10516	X10616	X10716	X11016	X11116
X17	X10017	X10117	X10217	X10317	X10417	X10517	X10617	X10717	X11017	X11117
	Expansion module no.11	Expansion module no.12	Expansion module no.13	Expansion module no.14	Expansion module no.15	Expansion module no.16				
X0	X11200	X11300	X11400	X11500	X11600	X11700				
X1	X11201	X11301	X11401	X11501	X11600	X11701				
X2	X11202	X11302	X11402	X11502	X11602	X11702				
X3	X11203	X11303	X11403	X11503	X11603	X11703				
X4	X11204	X11304	X11404	X11504	X11604	X11704				
X5	X11205	X11305	X11405	X11505	X11605	X11705				
X6	X11206	X11306	X11406	X11506	X11606	X11706				
X7	X11207	X11307	X11407	X11507	X11607	X11707				
X10	X11210	X11310	X11410	X11510	X11610	X11710				
X11	X11211	X11311	X11411	X11511	X11611	X11711				
X12	X11212	X11312	X11412	X11512	X11612	X11712				
X13	X11213	X11313	X11413	X11513	X11613	X11713				
X14	X11214	X11314	X11414	X11514	X11614	X11714				
X15	X11215	X11315	X11415	X11515	X11615	X11715				
X16	X11216	X11316	X11416	X11516	X11616	X11716				
X17	X11217	X11317	X11417	X11517	X11617	X11717				

	Expansion module no.1	Expansion module no.2	Expansion module no.3	Expansion module no.4	Expansion module no.5	Expansion module no.6	Expansion module no.7	Expansion module no.8	Expansion module no.9	Expansion module no.10
Y0	Y10000	Y10100	Y10200	Y10300	Y10400	Y10500	Y10600	Y10700	Y11000	Y11100
Y1	Y10001	Y10101	Y10201	Y10301	Y10401	Y10501	Y10601	Y10701	Y11001	Y11101
Y2	Y10002	Y10102	Y10202	Y10302	Y10402	Y10502	Y10602	Y10702	Y11002	Y11102
Y3	Y10003	Y10103	Y10203	Y10303	Y10403	Y10503	Y10603	Y10703	Y11003	Y11103
Y4	Y10004	Y10104	Y10204	Y10304	Y10404	Y10504	Y10604	Y10704	Y11004	Y11104
Y5	Y10005	Y10105	Y10205	Y10305	Y10405	Y10505	Y10605	Y10705	Y11005	Y11105
Y6	Y10006	Y10106	Y10206	Y10306	Y10406	Y10506	Y10606	Y10706	Y11006	Y11106
Y7	Y10007	Y10107	Y10207	Y10307	Y10407	Y10507	Y10607	Y10707	Y11007	Y11107
Y10	Y10010	Y10110	Y10210	Y10310	Y10410	Y10510	Y10610	Y10710	Y11010	Y11110
Y11	Y10011	Y10111	Y10211	Y10311	Y10411	Y10511	Y10611	Y10711	Y11011	Y11111
Y12	Y10012	Y10112	Y10212	Y10312	Y10412	Y10512	Y10612	Y10712	Y11012	Y11112

Y13	Y10013	Y10113	Y10213	Y10313	Y10413	Y10513	Y10613	Y10713	Y11013	Y11113
Y14	Y10014	Y10114	Y10214	Y10314	Y10414	Y10514	Y10614	Y10714	Y11014	Y11114
Y15	Y10015	Y10115	Y10215	Y10315	Y10415	Y10515	Y10615	Y10715	Y11015	Y11115
Y16	Y10016	Y10116	Y10216	Y10316	Y10416	Y10516	Y10616	Y10716	Y11016	Y11116
Y17	Y10017	Y10117	Y10217	Y10317	Y10417	Y10517	Y10617	Y10717	Y11017	X11117
	Expansion module no.11	Expansion module no.12	Expansion module no.13	Expansion module no.14	Expansion module no.15	Expansion module no.16				
Y0	Y11200	Y11300	Y11400	Y11500	Y11600	Y11700				
Y1	Y11201	Y11301	Y11401	Y11501	Y11600	Y11701				
Y2	Y11202	Y11302	Y11402	Y11502	Y11602	Y11702				
Y3	Y11203	Y11303	Y11403	Y11503	Y11603	Y11703				
Y4	Y11204	Y11304	Y11404	Y11504	Y11604	Y11704				
Y5	Y11205	Y11305	Y11405	Y11505	Y11605	Y11705				
Y6	Y11206	Y11306	Y11406	Y11506	Y11606	Y11706				
Y7	Y11207	Y11307	Y11407	Y11507	Y11607	Y11707				
Y10	Y11210	Y11310	Y11410	Y11510	Y11610	Y11710				
Y11	Y11211	Y11311	Y11411	Y11511	Y11611	Y11711				
Y12	Y11212	Y11312	Y11412	Y11512	Y11612	Y11712				
Y13	Y11213	Y11313	Y11413	Y11513	Y11613	Y11713				
Y14	Y11214	Y11314	Y11414	Y11514	Y11614	Y11714				
Y15	Y11215	Y11315	Y11415	Y11515	Y11615	Y11715				
Y16	Y11216	Y11316	Y11416	Y11516	Y11616	Y11716				
Y17	Y11217	Y11317	Y11417	Y11517	Y11617	Y11717				

● **XD-E32Y**

Expansion module no.1 to no.16 input terminal address:

	Expansion module no.1	Expansion module no.2	Expansion module no.3	Expansion module no.4	Expansion module no.5	Expansion module no.6	Expansion module no.7	Expansion module no.8	Expansion module no.9	Expansion module no.10
Y0	Y10000	Y10100	Y10200	Y10300	Y10400	Y10500	Y10600	Y10700	Y11000	Y11100
Y1	Y10001	Y10101	Y10201	Y10301	Y10401	Y10501	Y10601	Y10701	Y11001	Y11101
Y2	Y10002	Y10102	Y10202	Y10302	Y10402	Y10502	Y10602	Y10702	Y11002	Y11102
Y3	Y10003	Y10103	Y10203	Y10303	Y10403	Y10503	Y10603	Y10703	Y11003	Y11103
Y4	Y10004	Y10104	Y10204	Y10304	Y10404	Y10504	Y10604	Y10704	Y11004	Y11104
Y5	Y10005	Y10105	Y10205	Y10305	Y10405	Y10505	Y10605	Y10705	Y11005	Y11105
Y6	Y10006	Y10106	Y10206	Y10306	Y10406	Y10506	Y10606	Y10706	Y11006	Y11106
Y7	Y10007	Y10107	Y10207	Y10307	Y10407	Y10507	Y10607	Y10707	Y11007	Y11107
Y10	Y10010	Y10110	Y10210	Y10310	Y10410	Y10510	Y10610	Y10710	Y11010	Y11110

Y11	Y10011	Y10111	Y10211	Y10311	Y10411	Y10511	Y10611	Y10711	Y11011	Y11111
Y12	Y10012	Y10112	Y10212	Y10312	Y10412	Y10512	Y10612	Y10712	Y11012	Y11112
Y13	Y10013	Y10113	Y10213	Y10313	Y10413	Y10513	Y10613	Y10713	Y11013	Y11113
Y14	Y10014	Y10114	Y10214	Y10314	Y10414	Y10514	Y10614	Y10714	Y11014	Y11114
Y15	Y10015	Y10115	Y10215	Y10315	Y10415	Y10515	Y10615	Y10715	Y11015	Y11115
Y16	Y10016	Y10116	Y10216	Y10316	Y10416	Y10516	Y10616	Y10716	Y11016	Y11116
Y17	Y10017	Y10117	Y10217	Y10317	Y10417	Y10517	Y10617	Y10717	Y11017	X11117
Y20	Y10020	Y10120	Y10220	Y10320	Y10420	Y10520	Y10620	Y10720	Y11020	Y11120
Y21	Y10021	Y10121	Y10221	Y10321	Y10421	Y10521	Y10621	Y10721	Y11021	Y11121
Y22	Y10022	Y10122	Y10222	Y10322	Y10422	Y10522	Y10622	Y10722	Y11022	Y11122
Y23	Y10023	Y10123	Y10223	Y10323	Y10423	Y10523	Y10623	Y10723	Y11023	Y11123
Y24	Y10024	Y10124	Y10224	Y10324	Y10424	Y10524	Y10624	Y10724	Y11024	Y11124
Y25	Y10025	Y10125	Y10225	Y10325	Y10425	Y10525	Y10625	Y10725	Y11025	Y11125
Y26	Y10026	Y10126	Y10226	Y10326	Y10426	Y10526	Y10626	Y10726	Y11026	Y11126
Y27	Y10027	Y10127	Y10227	Y10327	Y10427	Y10527	Y10627	Y10727	Y11027	Y11127
Y30	Y10030	Y10130	Y10230	Y10330	Y10430	Y10530	Y10630	Y10730	Y11030	Y11130
Y31	Y10031	Y10131	Y10231	Y10331	Y10431	Y10531	Y10631	Y10731	Y11031	Y11131
Y32	Y10032	Y10132	Y10232	Y10332	Y10432	Y10532	Y10632	Y10732	Y11032	Y11132
Y33	Y10033	Y10133	Y10233	Y10333	Y10433	Y10533	Y10633	Y10733	Y11033	Y11133
Y34	Y10034	Y10134	Y10234	Y10334	Y10434	Y10534	Y10634	Y10734	Y11034	Y11134
Y35	Y10035	Y10135	Y10235	Y10335	Y10435	Y10535	Y10635	Y10735	Y11035	Y11135
Y36	Y10036	Y10136	Y10236	Y10336	Y10436	Y10536	Y10636	Y10736	Y11036	Y11136
Y37	Y10037	Y10137	Y10237	Y10337	Y10437	Y10537	Y10637	Y10737	Y11037	Y11137
	Expansion module no.11	Expansion module no.12	Expansion module no.13	Expansion module no.14	Expansion module no.15	Expansion module no.16				
Y0	Y11200	Y11300	Y11400	Y11500	Y11600	Y11700				
Y1	Y11201	Y11301	Y11401	Y11501	Y11601	Y11701				
Y2	Y11202	Y11302	Y11402	Y11502	Y11602	Y11702				
Y3	Y11203	Y11303	Y11403	Y11503	Y11603	Y11703				
Y4	Y11204	Y11304	Y11404	Y11504	Y11604	Y11704				
Y5	Y11205	Y11305	Y11405	Y11505	Y11605	Y11705				
Y6	Y11206	Y11306	Y11406	Y11506	Y11606	Y11706				
Y7	Y11207	Y11307	Y11407	Y11507	Y11607	Y11707				
Y10	Y11210	Y11310	Y11410	Y11510	Y11610	Y11710				
Y11	Y11211	Y11311	Y11411	Y11511	Y11611	Y11711				
Y12	Y11212	Y11312	Y11412	Y11512	Y11612	Y11712				
Y13	Y11213	Y11313	Y11413	Y11513	Y11613	Y11713				
Y14	Y11214	Y11314	Y11414	Y11514	Y11614	Y11714				
Y15	Y11215	Y11315	Y11415	Y11515	Y11615	Y11715				
Y16	Y11216	Y11316	Y11416	Y11516	Y11616	Y11716				
Y17	X11217	X11317	X11417	X11517	X11617	X11717				

Y20	Y11220	Y11320	Y11420	Y11520	Y11620	Y11720				
Y21	Y11221	Y11321	Y11421	Y11521	Y11621	Y11721				
Y22	Y11222	Y11322	Y11422	Y11522	Y11622	Y11722				
Y23	Y11223	Y11323	Y11423	Y11523	Y11623	Y11723				
Y24	Y11224	Y11324	Y11424	Y11524	Y11624	Y11724				
Y25	Y11225	Y11325	Y11425	Y11525	Y11625	Y11725				
Y26	Y11226	Y11326	Y11426	Y11526	Y11626	Y11726				
Y27	Y11227	Y11327	Y11427	Y11527	Y11627	Y11727				
Y30	Y11230	Y11330	Y11430	Y11530	Y11630	Y11730				
Y31	Y11231	Y11331	Y11431	Y11531	Y11631	Y11731				
Y32	Y11232	Y11332	Y11432	Y11532	Y11632	Y11732				
Y33	Y11233	Y11333	Y11433	Y11533	Y11633	Y11733				
Y34	Y11234	Y11334	Y11434	Y11534	Y11634	Y11734				
Y35	Y11235	Y11335	Y11435	Y11535	Y11635	Y11735				
Y36	Y11236	Y11336	Y11436	Y11536	Y11636	Y11736				
Y37	Y11237	Y11337	Y11437	Y11537	Y11637	Y11737				

● **XD-E32X**

Expansion module no.1 to no.16 input terminal address:

	Expansion module no.1	Expansion module no.2	Expansion module no.3	Expansion module no.4	Expansion module no.5	Expansion module no.6	Expansion module no.7	Expansion module no.8	Expansion module no.9	Expansion module no.10
X0	X10000	X10100	X10200	X10300	X10400	X10500	X10600	X10700	X11000	X11100
X1	X10001	X10101	X10201	X10301	X10401	X10501	X10601	X10701	X11001	X11101
X2	X10002	X10102	X10202	X10302	X10402	X10502	X10602	X10702	X11002	X11102
X3	X10003	X10103	X10203	X10303	X10403	X10503	X10603	X10703	X11003	X11103
X4	X10004	X10104	X10204	X10304	X10404	X10504	X10604	X10704	X11004	X11104
X5	X10005	X10105	X10205	X10305	X10405	X10505	X10605	X10705	X11005	X11105
X6	X10006	X10106	X10206	X10306	X10406	X10506	X10606	X10706	X11006	X11106
X7	X10007	X10107	X10207	X10307	X10407	X10507	X10607	X10707	X11007	X11107
X10	X10010	X10110	X10210	X10310	X10410	X10510	X10610	X10710	X11010	X11110
X11	X10011	X10111	X10211	X10311	X10411	X10511	X10611	X10711	X11011	X11111
X12	X10012	X10112	X10212	X10312	X10412	X10512	X10612	X10712	X11012	X11112
X13	X10013	X10113	X10213	X10313	X10413	X10513	X10613	X10713	X11013	X11113
X14	X10014	X10114	X10214	X10314	X10414	X10514	X10614	X10714	X11014	X11114
X15	X10015	X10115	X10215	X10315	X10415	X10515	X10615	X10715	X11015	X11115
X16	X10016	X10116	X10216	X10316	X10416	X10516	X10616	X10716	X11016	X11116
X17	X10017	X10117	X10217	X10317	X10417	X10517	X10617	X10717	X11017	X11117
X20	X10020	X10120	X10220	X10320	X10420	X10520	X10620	X10720	X11020	X11120

X21	X10021	X10121	X10221	X10321	X10421	X10521	X10621	X10721	X11021	X11121
X22	X10022	X10122	X10222	X10322	X10422	X10522	X10622	X10722	X11022	X11122
X23	X10023	X10123	X10223	X10323	X10423	X10523	X10623	X10723	X11023	X11123
X24	X10024	X10124	X10224	X10324	X10424	X10524	X10624	X10724	X11024	X11124
X25	X10025	X10125	X10225	X10325	X10425	X10525	X10625	X10725	X11025	X11125
X26	X10026	X10126	X10226	X10326	X10426	X10526	X10626	X10726	X11026	X11126
X27	X10027	X10127	X10227	X10327	X10427	X10527	X10627	X10727	X11027	X11127
X30	X10030	X10130	X10230	X10330	X10430	X10530	X10630	X10730	X11030	X11130
X31	X10031	X10131	X10231	X10331	X10431	X10531	X10631	X10731	X11031	X11131
X32	X10032	X10132	X10232	X10332	X10432	X10532	X10632	X10732	X11032	X11132
X33	X10033	X10133	X10233	X10333	X10433	X10533	X10633	X10733	X11033	X11133
X34	X10034	X10134	X10234	X10334	X10434	X10534	X10634	X10734	X11034	X11134
X35	X10035	X10135	X10235	X10335	X10435	X10535	X10635	X10735	X11035	X11135
X36	X10036	X10136	X10236	X10336	X10436	X10536	X10636	X10736	X11036	X11136
X37	X10037	X10137	X10237	X10337	X10437	X10537	X10637	X10737	X11037	X11137
	Expansion module no.11	Expansion module no.12	Expansion module no.13	Expansion module no.14	Expansion module no.15	Expansion module no.16				
X0	X11200	X11300	X11400	X11500	X11600	X11700				
X1	X11201	X11301	X11401	X11501	X11601	X11701				
X2	X11202	X11302	X11402	X11502	X11602	X11702				
X3	X11203	X11303	X11403	X11503	X11603	X11703				
X4	X11204	X11304	X11404	X11504	X11604	X11704				
X5	X11205	X11305	X11405	X11505	X11605	X11705				
X6	X11206	X11306	X11406	X11506	X11606	X11706				
X7	X11207	X11307	X11407	X11507	X11607	X11707				
X10	X11210	X11310	X11410	X11510	X11610	X11710				
X11	X11211	X11311	X11411	X11511	X11611	X11711				
X12	X11212	X11312	X11412	X11512	X11612	X11712				
X13	X11213	X11313	X11413	X11513	X11613	X11713				
X14	X11214	X11314	X11414	X11514	X11614	X11714				
X15	X11215	X11315	X11415	X11515	X11615	X11715				
X16	X11216	X11316	X11416	X11516	X11616	X11716				
X17	X11217	X11317	X11417	X11517	X11617	X11717				
X20	X11220	X11320	X11420	X11520	X11620	X11720				
X21	X11221	X11321	X11421	X11521	X11621	X11721				
X22	X11222	X11322	X11422	X11522	X11622	X11722				
X23	X11223	X11323	X11423	X11523	X11623	X11723				
X24	X11224	X11324	X11424	X11524	X11624	X11724				
X25	X11225	X11325	X11425	X11525	X11625	X11725				
X26	X11226	X11326	X11426	X11526	X11626	X11726				
X27	X11227	X11327	X11427	X11527	X11627	X11727				

X30	X11230	X11330	X11430	X11530	X11630	X11730				
X31	X11231	X11331	X11431	X11531	X11631	X11731				
X32	X11232	X11332	X11432	X11532	X11632	X11732				
X33	X11233	X11333	X11433	X11533	X11633	X11733				
X34	X11234	X11334	X11434	X11534	X11634	X11734				
X35	X11235	X11335	X11435	X11535	X11635	X11735				
X36	X11236	X11336	X11436	X11536	X11636	X11736				
X37	X11237	X11337	X11437	X11537	X11637	X11737				

10-4. External connection

(1) The input terminal connection diagram:

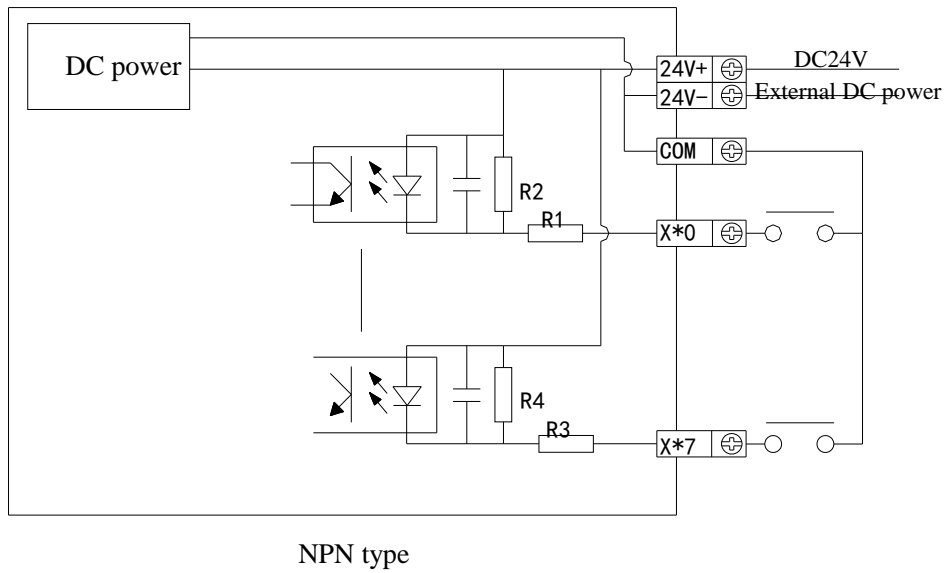

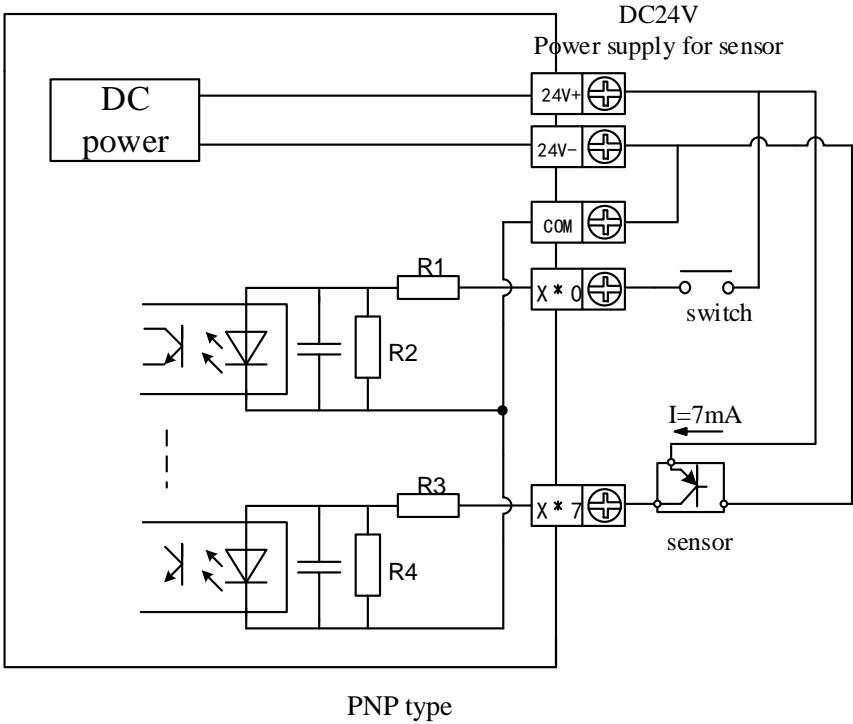

(2) The output terminal connection diagram:

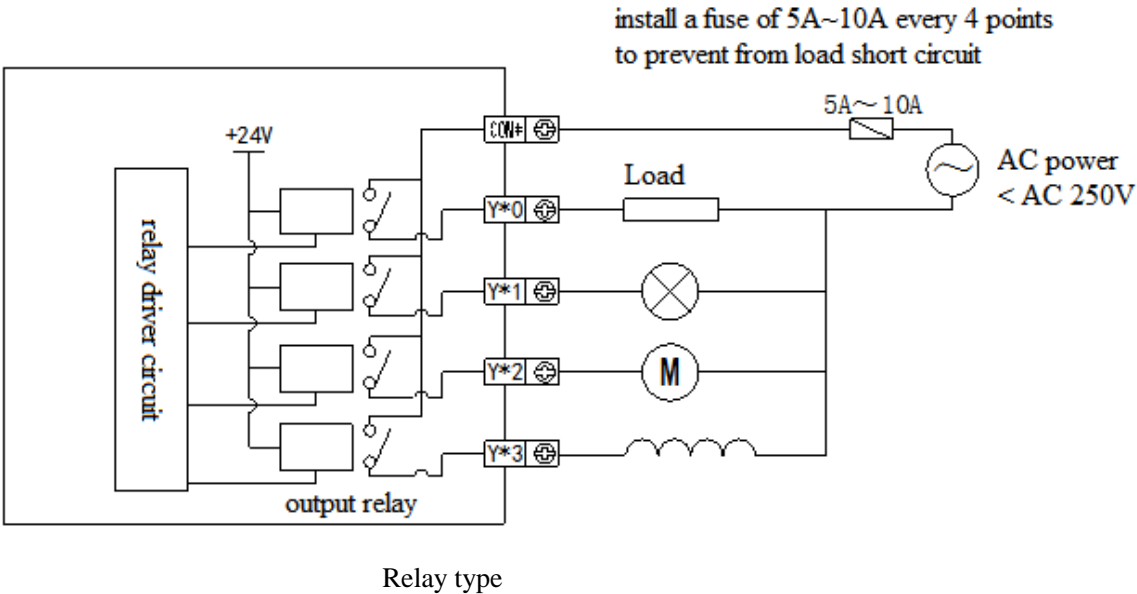

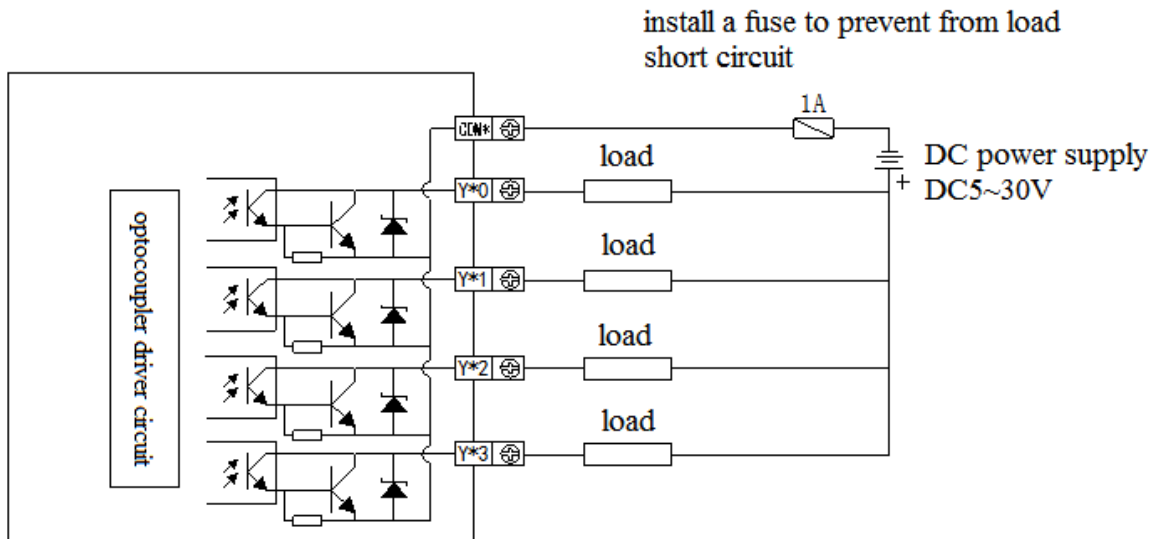

Transistor type

10-5. Module parameters

There are two parameters for the module: positive or negative logic, filter time.

There are two setting methods:

- (1) XDPpro software

Open the XDPpro software, click configure/expansion module settings:

Set the model and channel parameters in the following window. Then click write to PLC.

Please restart the PLC after setting.

Note: please select XD/E-8X8Y for configuring XD-E8X, XD-E8YR, XD-E8YT.

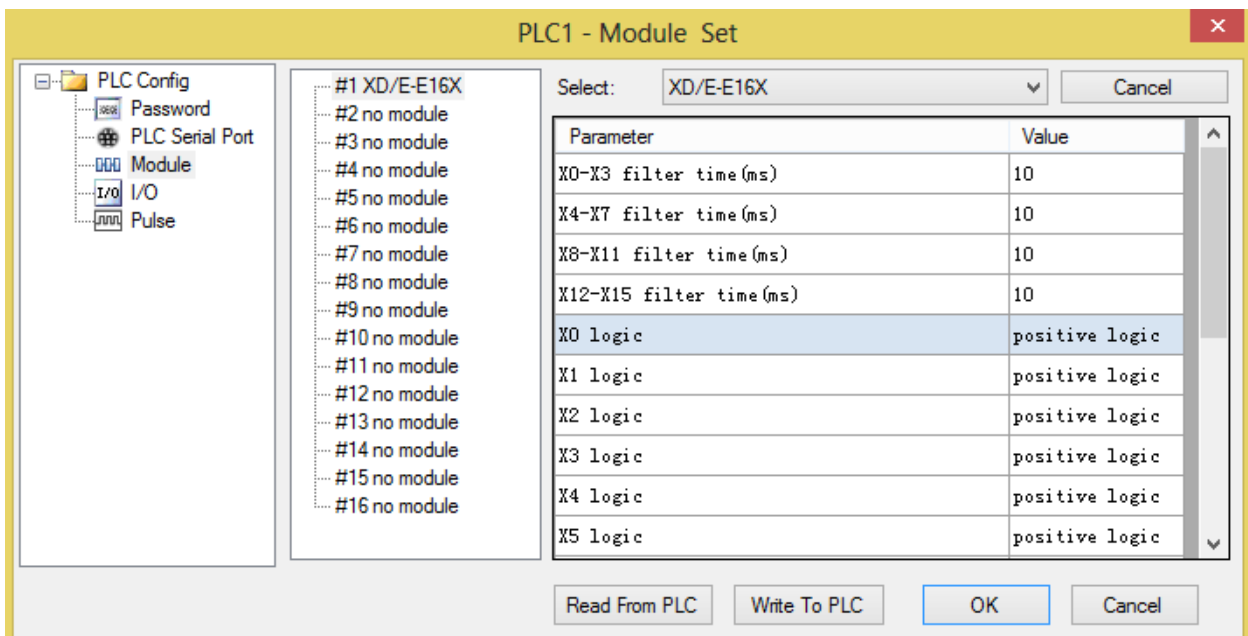

(2) Set through SFD register

Module no.	SFD address	Module no.	SFD address
#1	SFD350~SFD359	#9	SFD430~SFD439
#2	SFD360~SFD369	#10	SFD440~SFD449
#3	SFD370~SFD379	#11	SFD450~SFD459
#4	SFD380~SFD389	#12	SFD460~SFD469
#5	SFD390~SFD399	#13	SFD470~SFD479
#6	SFD400~SFD409	#14	SFD480~SFD489
#7	SFD410~SFD419	#15	SFD490~SFD499
#8	SFD420~SFD429	#16	SFD500~SFD509

The first 20 bytes definitions:

■ **XD-E8X8YR, XD-E8X8YT**

	Byte0	Byte1	Byte2	Byte3	Byte4	Byte5	Byte6~ Byte19
Bit7	X0~X3 filter time	X4~X7 filter time	-	-	-	-	-
Bit6			X3 logic	X7 logic	Y3 logic	Y7 logic	-
Bit5			-	-	-	-	-
Bit4			X2 logic	X6 logic	Y2 logic	Y6 logic	-
Bit3			-	-	-	-	-
Bit2			X1 logic	X5 logic	Y1 logic	Y5 logic	-
Bit1			-	-	-	-	-
Bit0			X0 logic	X4 logic	Y0 logic	Y4 logic	-
note	filter time (ms) setting range: 1~5, 10, 15, 20, 25, 30, 35, 40, 45, 50. Default value is 10ms.		0 is positive logic 1 is negative logic				-

■ XD-E8YR, XD-E8YT

	Byte0	Byte1	Byte2	Byte3	Byte4	Byte5	Byte6~Byte19
Bit7	-	-	-	-	-	-	-
Bit6			-	-	Y3 logic	Y7 logic	-
Bit5			-	-	-	-	-
Bit4			-	-	Y2 logic	Y6 logic	-
Bit3			-	-	-	-	-
Bit2			-	-	Y1 logic	Y5 logic	-
Bit1			-	-	-	-	-
Bit0			-	-	Y0 logic	Y4 logic	-
note	filter time (ms) setting range: 1~5, 10, 15, 20, 25, 30, 35, 40, 45, 50. Default value is 10ms.		0 is positive logic 1 is negative logic			-	

■ XD-E8X

	Byte0	Byte1	Byte2	Byte3	Byte4	Byte5	Byte6~Byte19
Bit7	X0~X3 filter time	X4~X7 filter time	-	-	-	-	-
Bit6			X3 logic	X7 logic	-	-	-
Bit5			-	-	-	-	-
Bit4			X2 logic	X6 logic	-	-	-
Bit3			-	-	-	-	-
Bit2			X1 logic	X5 logic	-	-	-
Bit1			-	-	-	-	-
Bit0			X0 logic	X4 logic	-	-	-
note	filter time (ms) setting range: 1~5, 10, 15, 20, 25, 30, 35, 40, 45, 50. Default value is 10ms.		0 is positive logic 1 is negative logic			-	

■ XD-E16X

	Byte0	Byte1	Byte2	Byte3	Byte 4	Byte 5	Byte 6	Byte 7	Byte8~Byte19
Bit7	X0~X3 filter time	X4~X7 filter time	X10~X13 filter time	X14~X17 Filter time	-	-	-	-	-
Bit6					X3 logic	X7 logic	X13 logic	X17 logic	-
Bit5					-	-	-	-	-
Bit4					X2 logic	X6 logic	X12 logic	X16 logic	-
Bit3					-	-	-	-	-

Bit2					X1 logic	X5 logic	X11 logic	X15 logic	-
Bit1					-	-	-	-	-
Bit0					X0 logic	X4 logic	X10 logic	X14 logic	-
note	filter time (ms) setting range: 1~5, 10, 15, 20, 25, 30, 35, 40, 45, 50. Default value is 10ms.				0 is positive logic 1 is negative logic				-

■ **XD-E16X16Y**

	Bit0	Bit1	Bit2	Bit3	Bit4	Bit5	Bit6	Bit7	Notes
Byte0	X0~X3 filter time								filter time (ms) setting range: 1~5, 10, 15, 20, 25, 30, 35, 40, 45, 50. Default value is 10ms.
Byte1	X4~X7 filter time								
Byte2	X10~X13 filter time								
Byte3	X14~X17 filter time								
Byte4	X0 logic	-	X1 logic	-	X2 logic	-	X3 logic	-	0 is positive logic 1 is negative logic
Byte5	X4 logic	-	X5 logic	-	X6 logic	-	X7 logic	-	
Byte6	X10 logic	-	X11 logic	-	X12 logic	-	X13 logic	-	
Byte7	X14 logic	-	X15 logic	-	X16 logic	-	X17 logic	-	
Byte8	Y0 logic	-	Y1 logic	-	Y2 logic	-	Y3 logic	-	
Byte9	Y4 logic	-	Y5 logic	-	Y6 logic	-	Y7 logic	-	
Byte10	Y10 logic	-	Y11 logic	-	Y12 logic	-	Y13 logic	-	
Byte11	Y14 logic	-	Y15 logic	-	Y16 logic	-	Y17 logic	-	
Byte 12~19	-	-	-	-	-	-	-	-	

■ **XD-E16Y/XD-E32Y**

	Bit0	Bit1	Bit2	Bit3	Bit4	Bit5	Bit6	Bit7	Notes
Byte0	Y0 logic	-	Y1 logic	-	Y2 logic	-	Y3 logic	-	0 is positive logic 1 is negative logic
Byte1	Y4 logic	-	Y5 logic	-	Y6 logic	-	Y7 logic	-	
Byte2	Y10 logic	-	Y11 logic	-	Y12 logic	-	Y13 logic	-	
Byte3	Y14 logic	-	Y15 logic	-	Y16 logic	-	Y17 logic	-	
Byte4	Y20 logic	-	Y21 logic	-	Y22 logic	-	Y23 logic	-	
Byte5	Y24 logic	-	Y25 logic	-	Y26 logic	-	Y27 logic	-	

Byte6	Y30 logic	-	Y31 logic	-	Y32 logic	-	Y33 logic	-	
Byte7	Y34 logic	-	Y35 logic	-	Y36 logic	-	Y37 logic	-	
Byte8~19	-	-	-	-	-	-	-	-	

■ **XD-E32X**

	Bit0	Bit1	Bit2	Bit3	Bit4	Bit5	Bit6	Bit7	Notes
Byte0	X0~X3 filter time								filter time (ms) setting range: 1~5, 10, 15, 20, 25, 30, 35, 40, 45, 50. Default value is 10ms.
Byte1	X4~X7 filter time								
Byte2	X10~X13 filter time								
Byte3	X14~X17 filter time								
Byte4	X20~X23 filter time								
Byte5	X24~X27 filter time								
Byte6	X30~X33 filter time								
Byte7	X34~X37 filter time								0 is positive logic 1 is negative logic
Byte8	X0 logic	-	X1 logic	-	X2 logic	-	X3 logic	-	
Byte9	X4 logic	-	X5 logic	-	X6 logic	-	X7 logic	-	
Byte10	X10 logic	-	X11 logic	-	X12 logic	-	X13 logic	-	
Byte11	X14 logic	-	X15 logic	-	X16 logic	-	X17 logic	-	
Byte12	X20 logic	-	X21 logic	-	X22 logic	-	X23 logic	-	
Byte13	X24 logic	-	X25 logic	-	X26 logic	-	X27 logic	-	
Byte14	X30 logic	-	X31 logic	-	X32 logic	-	X33 logic	-	
Byte15	X34 logic	-	X35 logic	-	X36 logic	-	X37 logic	-	
Byte 16~19	-	-	-	-	-	-	-	-	

Note:

1. User can set the discrete input filter time, the time can be 1, 2, 3, 4, 5, 10, 15, 20, 25, 30, 35, 40, 45, 50. The default filter time is 10ms.
2. User can set the discrete input and output polarity: 0 is positive logic; 1 is negative logic.

10-6. Applications

The application example includes three devices: Xinje XD3 series PLC (slave station), expansion module XD-E8X8YR and HMI TH765-NT.

The communication between XD-E8X8YR and TH765-NT:

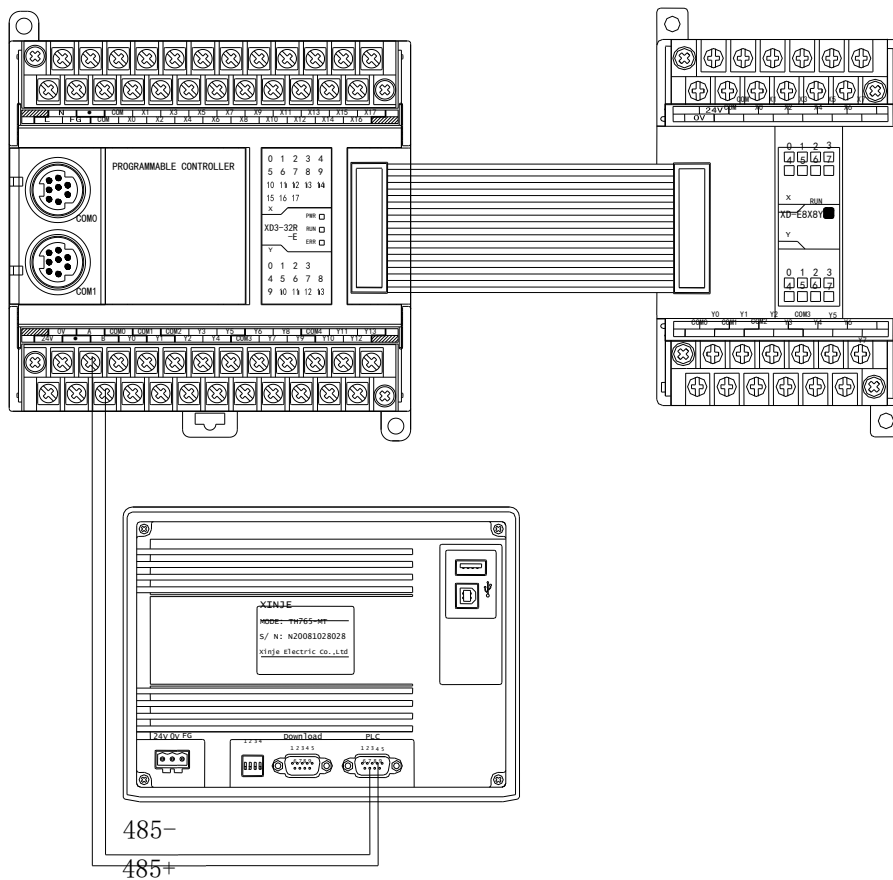

In this example, the HMI is the master station, read the input status of extension module to the HMI, writes the coil status of HMI to the extension module.

(1) Hardware connection: Connect XD-E8X8YR with XD3-32R-E, connect AB terminals of XD3-32R-E to AB terminals (PLC port) of TH765-NT.

Communication parameters setting of PLC:

Baud rate: 19200bps, Data bits: 8bits, Stop bits: 1bit, Parity: even, Modbus number: 1, restart the PLC after setting.

Touchwin software settings for TH765-NT:

PLC port device: “Modbus RTU (Panel is master)”, Baud rate: 19200bps, Data bits: 8bits, Stop bits: 1bit, Parity: even.

(2) Program application:

The corresponding relationship between expansion module address and HMI address:

HMI address	Expansion module	Related MODBUS address
PSB500	X10000	K20736
PSB501	Y10000	K24832

(3) HMI screen editing:

The screen of HMI:

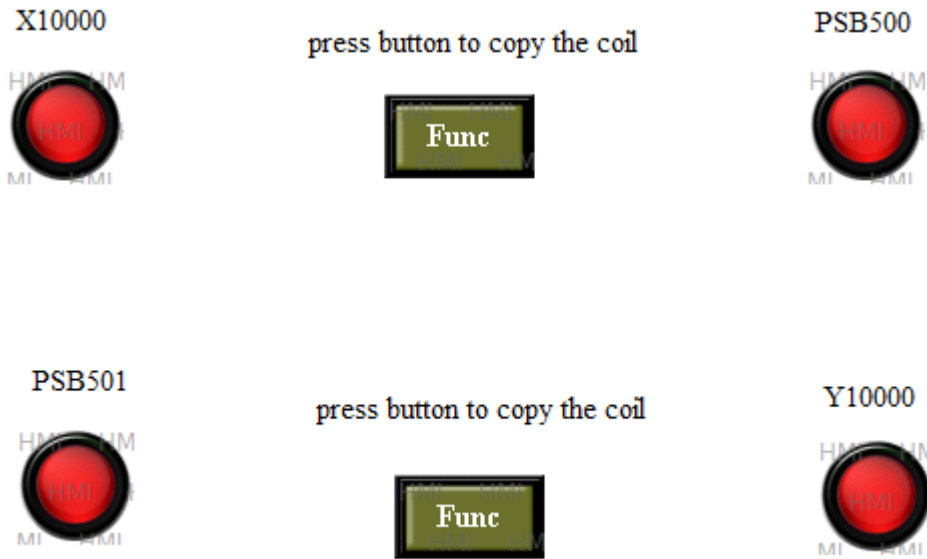

Edit the status of X10000:

Lamp X10000: the Modbus address of expansion module coil X10000 is 0x20736 (diagram A).

Function Button: copy the coil status of X10000 to PSB500 when the button is pressed (diagram B).

Lamp PSB500: HMI internal coil address is PSB500. (diagram C)

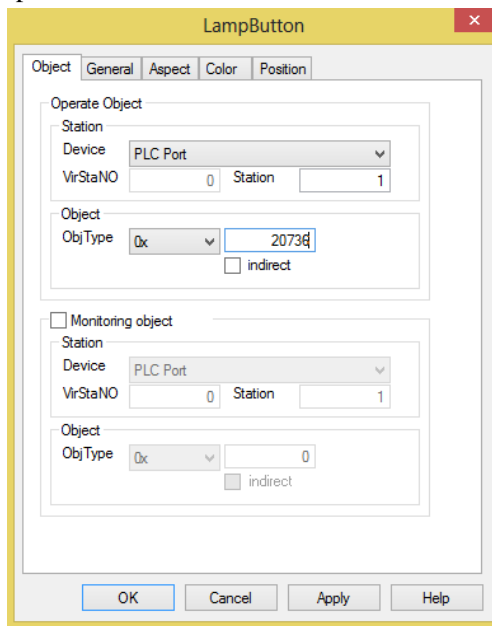

Diagram A

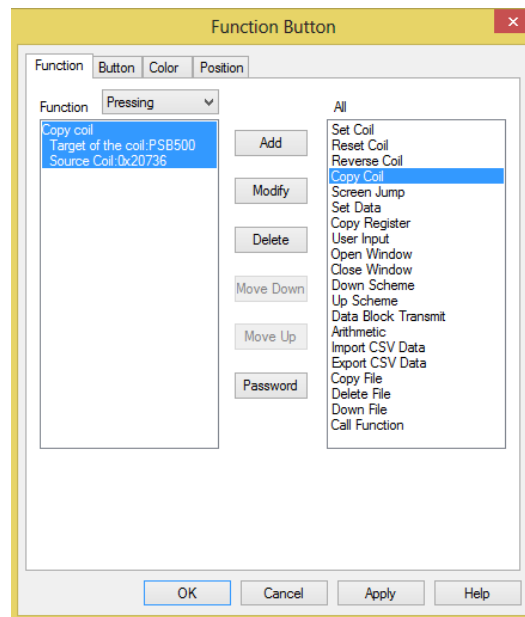

Diagram B

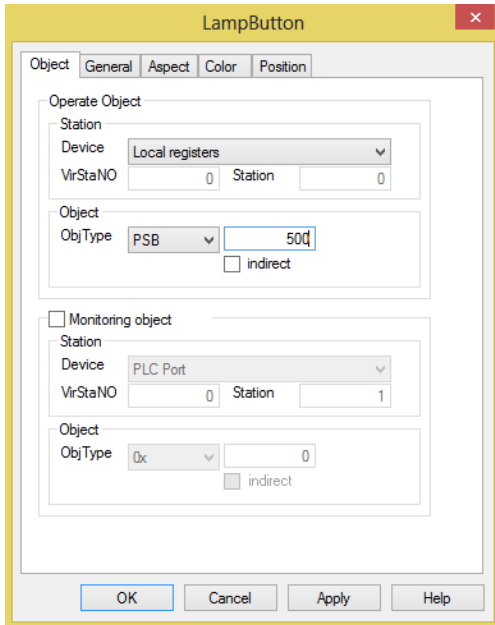

Diagram C

Edit the status of PSB501:

Lamp PSB501: the HMI internal coil address is PSB501 (diagram D);

Function Button: copy the coil status of PSB501 to Y10000 when the button is pressed (diagram E);

Lamp Y10000: the Modbus address of expansion module coil Y10000 is 0x24832 (diagram F).

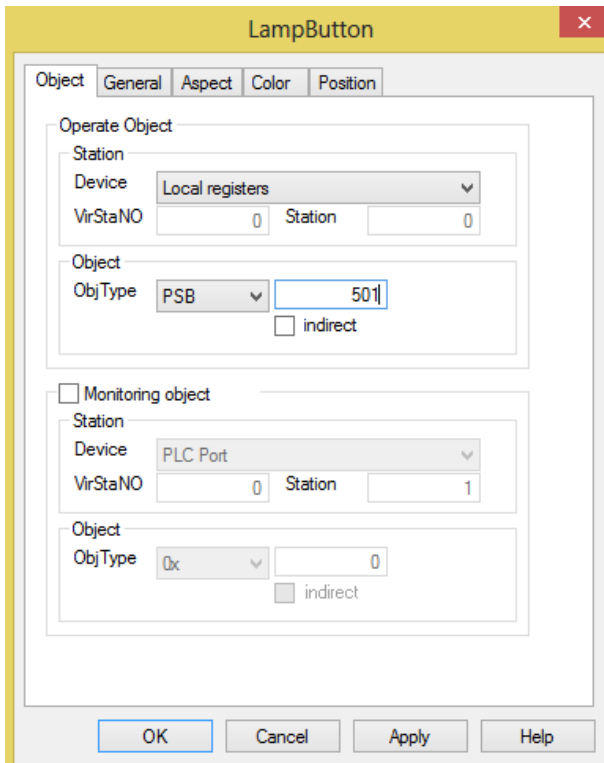

Diagram D

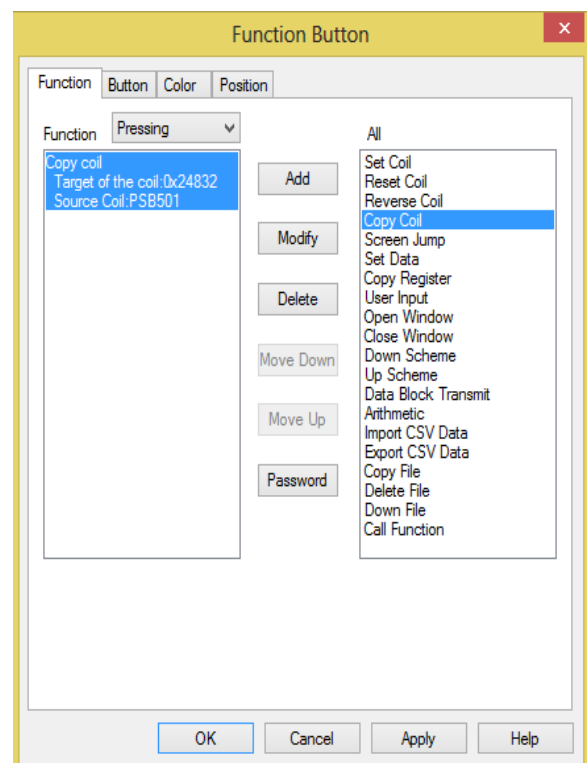

Diagram E

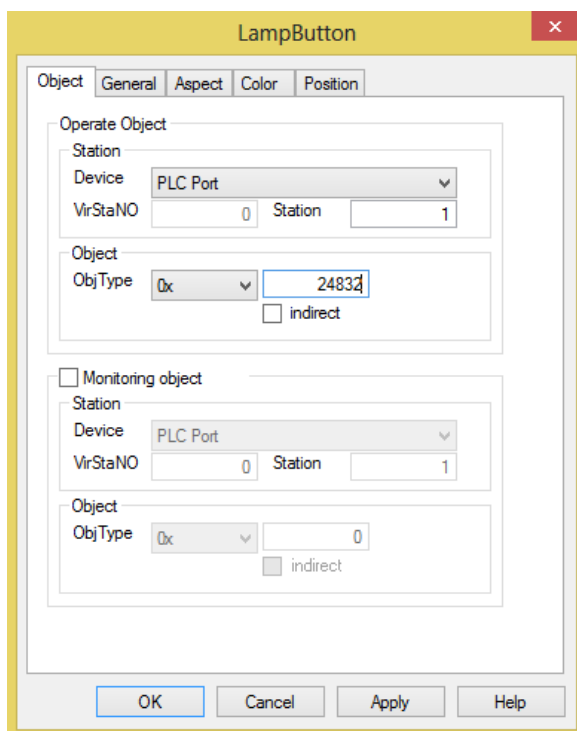

Diagram F

After editing the HMI screen, download it to the HMI and start to work.

11. Analog input/output module XD-E4AD2DA-B

11-1. Specification

XD-E4AD2DA-B transform the 4 channels analog value to digital value, 2 channels digital value to analog value, and send them to PLC.

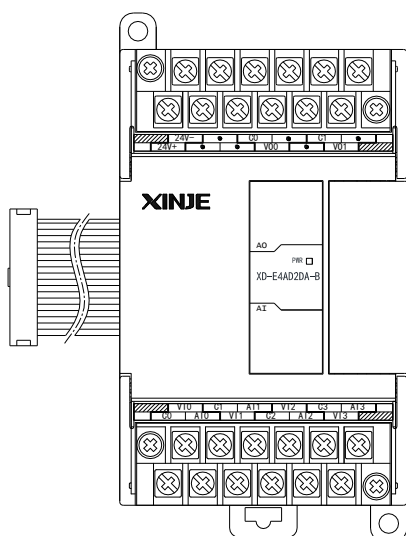

- 4 channels analog input: voltage input and current input
- 2 channels analog voltage output: -10V~10V or -5V~5V.
- 14 bits high precision analog input
- XD3 series PLC can connect 10 modules. (XDM series can connect 16 modules)

Items	Analog input (AD)		Analog output (DA)
	Voltage input	Current input	Voltage output
Analog input bound	0~5V, 0~10V	0~20mA, 4~20mA	-
Max input bound	DC ±15V	0~40mA	-
Analog output bound	-		-5~5V, -10~10V (Exterior load resistance 2KΩ~1MΩ)
Digital input bound	-		12 bits binary data (0~4095)
Digital output bound	14 bits binary data (0~16383)		-
Distinguish ratio	1/16383(14Bit)		1/4095(12Bit)
PID control value	0~4095		-
Integrate precision	1%		
Convert speed	2ms per channel		2ms per channel
Power used by analog	DC24V ±10%, 150mA		
Install format	Fixed with M3 screws or directly installed on orbit of DIN46277 (Width: 35mm)		
Exterior size	63mm×108mm×79.9mm		

11-2. Terminals

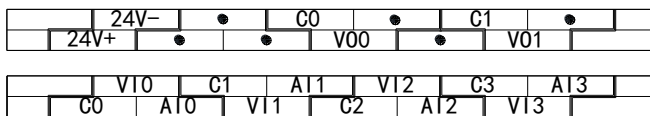

Channel	Terminal name	Signal name
CH0	AI0	Current input
	VI0	Voltage input
	C0	CH0 common terminal of analog input
CH1	AI1	Current input
	VI1	Voltage input
	C1	CH1 common terminal of analog input
CH2	AI2	Current input
	VI2	Voltage input
	C2	CH2 common terminal of analog input
CH3	AI3	Current input
	VI3	Voltage input
	C3	CH3 common terminal of analog input
CH0	VO0	Voltage output
	C0	CH0 common terminal of analog output
CH1	VO1	Voltage output
	C1	CH1 common terminal of analog output

	24V+	+24V power supply
-	24V-	Common terminal of power supply

11-3. The assignment of I/O address

XD series analog modules do not occupy I/O units; the converted data is directly transferred into PLC register,

Register address of module1:

Channel	AD signal	Channel enable bit (set ON the bit to use this channel)
0CH	ID10000	Y10000
1CH	ID10001	Y10001
2CH	ID10002	Y10002
3CH	ID10003	Y10003
Channel	DA signal	
0CH	QD10000	Y10004
1CH	QD10001	Y10005

Register address of module2:

Channel	AD signal	Channel enable bit (set ON the bit to use this channel)
0CH	ID10100	Y10100
1CH	ID10101	Y10101
2CH	ID10102	Y10102
3CH	ID10103	Y10103
Channel	DA signal	
0CH	QD10100	Y10104
1CH	QD10101	Y10105

Register address of module3:

Channel	AD signal	Channel enable bit (set ON the bit to use this channel)
0CH	ID10200	Y10200
1CH	ID10201	Y10201
2CH	ID10202	Y10202
3CH	ID10203	Y10203
Channel	DA signal	

0CH	QD10200	Y10204
1CH	QD10201	Y10205

Register address of module4:

Channel	AD signal	Channel enable bit (set ON the bit to use this channel)
0CH	ID10300	Y10300
1CH	ID10301	Y10301
2CH	ID10302	Y10302
3CH	ID10303	Y10303
Channel	DA signal	
0CH	QD10300	Y10304
1CH	QD10301	Y10305

Register address of module5:

Channel	AD signal	Channel enable bit (set ON the bit to use this channel)
0CH	ID10400	Y10400
1CH	ID10401	Y10401
2CH	ID10402	Y10402
3CH	ID10403	Y10403
Channel	DA signal	
0CH	QD10400	Y10404
1CH	QD10401	Y10405

Register address of module6:

Channel	AD signal	Channel enable bit (set ON the bit to use this channel)
0CH	ID10500	Y10500
1CH	ID10501	Y10501
2CH	ID10502	Y10502
3CH	ID10503	Y10503
Channel	DA signal	
0CH	QD10500	Y10504
1CH	QD10501	Y10505

Register address of module7:

Channel	AD signal	Channel enable bit (set ON the bit to use this channel)
0CH	ID10600	Y10600
1CH	ID10601	Y10601
2CH	ID10602	Y10602
3CH	ID10603	Y10603
Channel	DA signal	
0CH	QD10600	Y10604
1CH	QD10601	Y10605

Register address of module8:

Channel	AD signal	Channel enable bit (set ON the bit to use this channel)
0CH	ID10700	Y10700
1CH	ID10701	Y10701
2CH	ID10702	Y10702
3CH	ID10703	Y10703
Channel	DA signal	
0CH	QD10700	Y10704
1CH	QD10701	Y10705

Register address of module9:

Channel	AD signal	Channel enable bit (set ON the bit to use this channel)
0CH	ID10800	Y11000
1CH	ID10801	Y11001
2CH	ID10802	Y11002
3CH	ID10803	Y11003
Channel	DA signal	
0CH	QD10800	Y11004
1CH	QD10801	Y11005

Register address of module10:

Channel	AD signal	Channel enable bit (set ON the bit to use this channel)
0CH	ID10900	Y11100
1CH	ID10901	Y11101

2CH	ID10902	Y11102
3CH	ID10903	Y11103
Channel	DA signal	
0CH	QD10900	Y11104
1CH	QD10901	Y11105

Register address of module11:

Channel	AD signal	Channel enable bit (set ON the bit to use this channel)
0CH	ID11000	Y11200
1CH	ID11001	Y11201
2CH	ID11002	Y11202
3CH	ID11003	Y11203
Channel	DA signal	
0CH	QD11000	Y11204
1CH	QD11001	Y11205

Register address of module12:

Channel	AD signal	Channel enable bit (set ON the bit to use this channel)
0CH	ID11100	Y11300
1CH	ID11101	Y11301
2CH	ID11102	Y11302
3CH	ID11103	Y11303
Channel	DA signal	
0CH	QD11100	Y11304
1CH	QD11101	Y11305

Register address of module13:

Channel	AD signal	Channel enable bit (set ON the bit to use this channel)
0CH	ID11200	Y11400
1CH	ID11201	Y11401
2CH	ID11202	Y11402
3CH	ID11203	Y11403
Channel	DA signal	
0CH	QD11200	Y11404

1CH	QD11201	Y11405
-----	---------	--------

Register address of module14:

Channel	AD signal	Channel enable bit (set ON the bit to use this channel)
0CH	ID11300	Y11500
1CH	ID11301	Y11501
2CH	ID11302	Y11502
3CH	ID11303	Y11503
Channel	DA signal	
0CH	QD11300	Y11504
1CH	QD11301	Y11505

Register address of module15:

Channel	AD signal	Channel enable bit (set ON the bit to use this channel)
0CH	ID11400	Y11600
1CH	ID11401	Y11601
2CH	ID11402	Y11602
3CH	ID11403	Y11603
Channel	DA signal	
0CH	QD11400	Y11604
1CH	QD11401	Y11605

Register address of module16:

Channel	AD signal	Channel enable bit (set ON the bit to use this channel)
0CH	ID11500	Y11700
1CH	ID11501	Y11701
2CH	ID11502	Y11702
3CH	ID11503	Y11703
Channel	DA signal	
0CH	QD11500	Y11704
1CH	QD11501	Y11705

Note:

1. Forbid the unused channel to improve the I/O scanning speed.
2. If set off the enable bit of the input channel, this channel will not accept the data. (the data display is 0).

3. If set off the enable bit of the output channel, this channel will keep the former data.

11-4. Working mode

There are two ways to set the working mode:

1. XDPpro software
2. Flash registers of PLC

XDPpro software:

Open the XDPpro software, click configure/expansion module settings.

Set the model and channel parameters in the following window. Then click write to PLC.

Please restart the PLC after setting.

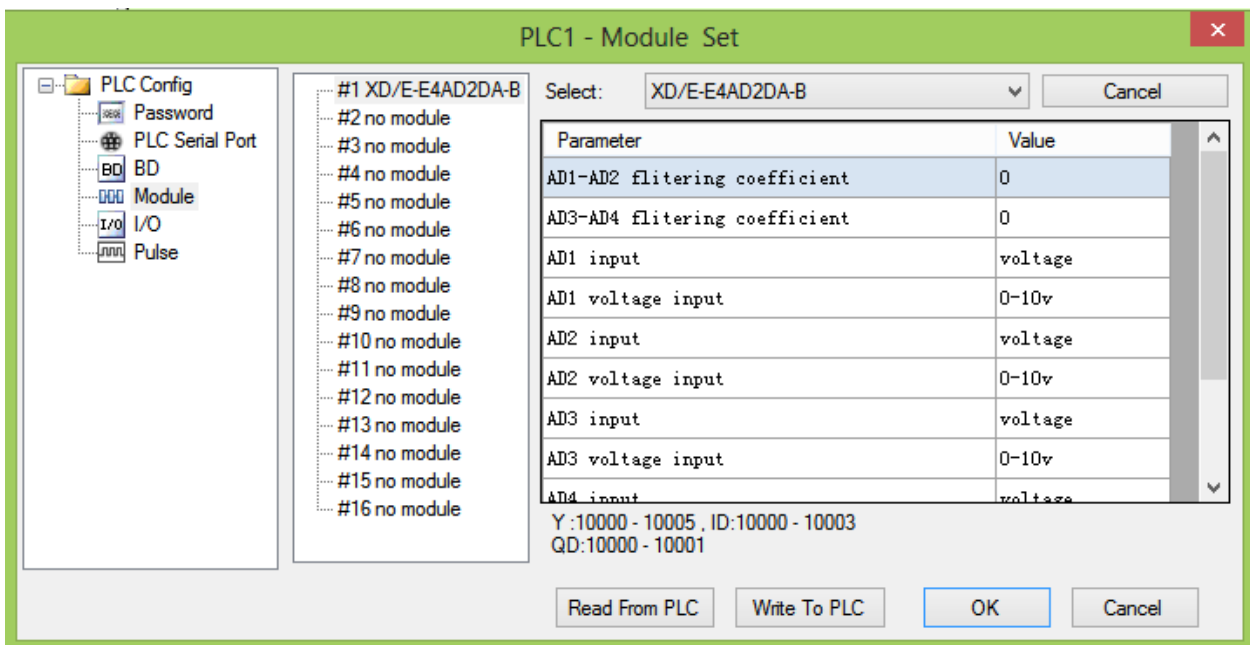

Note: first-order low-pass filter will weighted present sampling value with last time filter output to get the final filter value. The filter factor range is 0 to 255, the default value is 0 which means no filter.

Flash registers:

The module has current and voltage mode. Current has choices of 0~20mA, 4~20mA; voltage has choices of -5~5V, -10~10V. These parameters can be set through SFD registers.

Module no.	SFD address	Module no.	SFD address
#1	SFD350~SFD359	#9	SFD430~SFD439
#2	SFD360~SFD369	#10	SFD440~SFD449

#3	SFD370~SFD379	#11	SFD450~SFD459
#4	SFD380~SFD389	#12	SFD460~SFD469
#5	SFD390~SFD399	#13	SFD470~SFD479
#6	SFD400~SFD409	#14	SFD480~SFD489
#7	SFD410~SFD419	#15	SFD490~SFD499
#8	SFD420~SFD429	#16	SFD500~SFD509

Note: As shown in the preceding table, every register set 4 channels mode, each register has 16 bits, from low to high, every 4 bits set 1 channel mode.

SFD register bit definition:

Module no.1:

	Bit7	Bit6	Bit5	Bit4	Bit3	Bit2	Bit1	Bit0	Explanation
Byte0	AD channel 1, channel 2 filter time								AD filter time
Byte1	AD channel 3, channel 4 filter time								
Byte2	Bit7	Bit6	Bit5	Bit4	Bit3	Bit2	Bit1	Bit0	To define the AD and DA input range. Byte2 low 4 bits are AD channel 1, high 4 bits are AD channel 2.
	AD2				AD1				
	-	-	0: voltage input 1: current input	0: 0~10V 1: 0~5V 0: 0~20mA 1: 4~20mA	-	-	0: voltage input 1: current input	0: 0~10V 1: 0~5V 0: 0~20mA 1: 4~20mA	
Byte3	Bit7	Bit6	Bit5	Bit4	Bit3	Bit2	Bit1	Bit0	Byte3 low 4 bits are AD channel 3, high 4 bits are AD channel 4.
	AD4				AD3				
	-	-	0: voltage input 1: current input	0: 0~10V 1: 0~5V 0: 0~20mA 1: 4~20mA	-	-	0: voltage input 1: current input	0: 0~10V 1: 0~5V 0: 0~20mA 1: 4~20mA	
Byte4	Bit7	Bit6	Bit5	Bit4	Bit3	Bit2	Bit1	Bit0	Byte4 low 4 bits are DA channel 1, high 4 bits are DA channel 2.
	DA2				DA1				
	-	-	0: voltage output	0: -10~10V 1: -5~5V	-	-	0: voltage output	0: -10~10V 1: -5~5V	
Byte5 ~ Byte19	-								

For example:

Set the module no.1 AD channel 3, 2, 1, 0 working mode to 0~20mA, 4~20mA, 0~10V, 0~5V. Set the channel 1 and 2 filter factor to 255, set the channel 3 and 4 filter factor to 100. Set DA channel 1 and 0 working mode to -10~10V, -5~5V.

So the SFD register values are:

SFD350=64FFH SFD351=3210H SFD352=0001H SFD353=0000H SFD354=0000H

11-5. Exterior connection

When make exterior connection, please read the following items:

- When connect +24V power, please choose 24V power of PLC to avoid interference.
- To avoid interference, please use shield cable and single point ground for the shield layer.

Voltage input

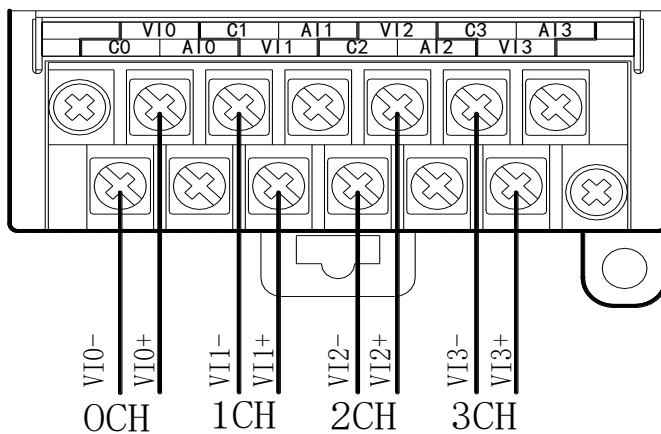

Current input

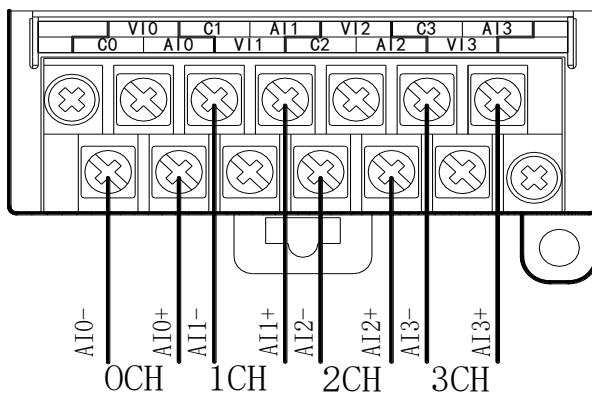

XD-E4AD2DA-B current input wiring:

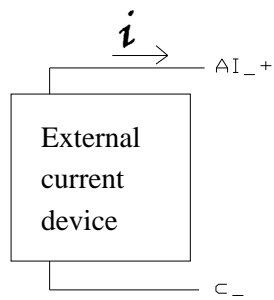

Voltage output:

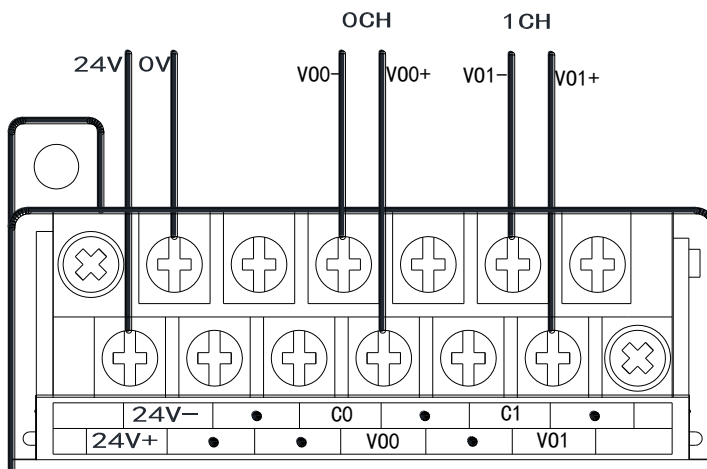

11-6. AD conversion diagram

The relationship between analog input and corresponding digital value:

0~5V analog input	0~10V analog input
0~20mA analog input	4~20mA analog input

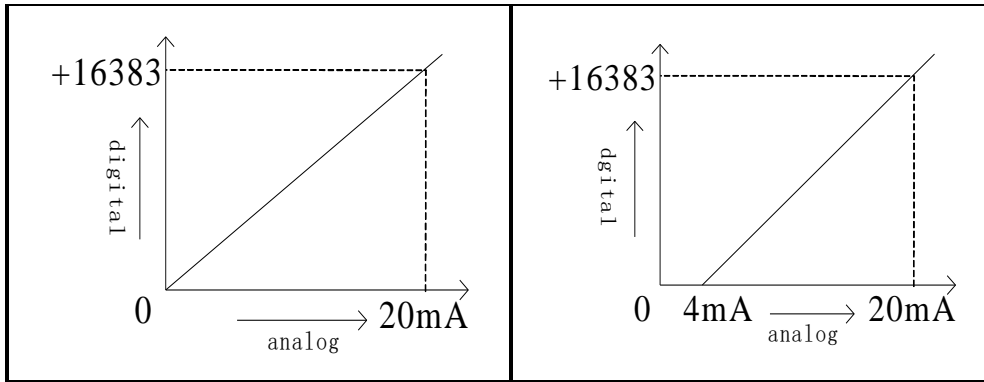

The relationship between input digital value and corresponding analog value:

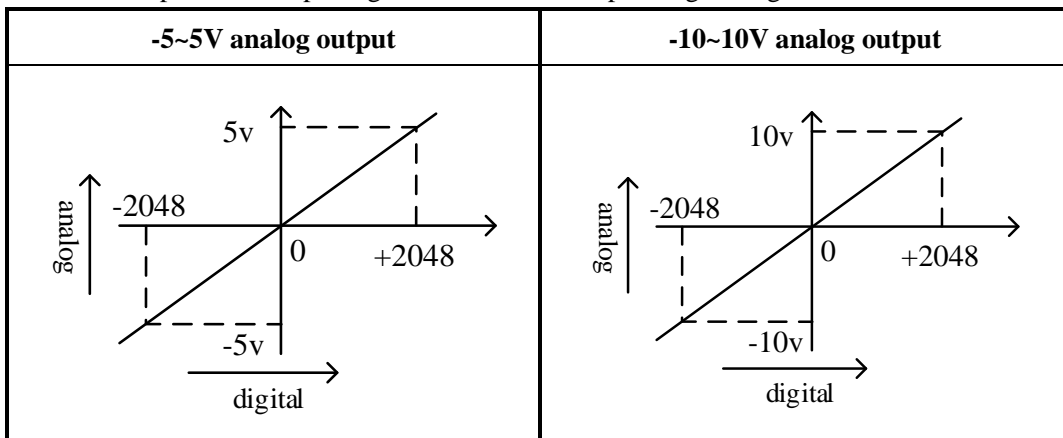

Note: When input data exceeds $K \pm 2048$, analog output will keep the value of $\pm 5V$, $\pm 10V$.

11-7. Programming

Example Real time read 4 channels data, write 2 channels data (take module no. 1 as an example)

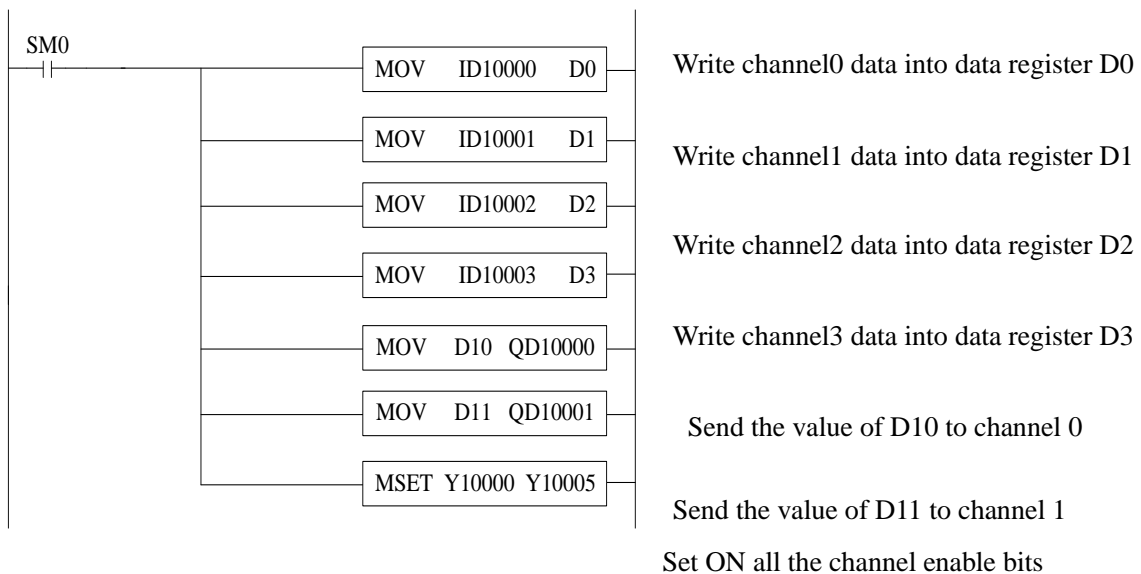

12. Analog output module XD-E4DA

12-1. Specifications

XD-E4DA module transforms 4 channels digital value to analog value and send the data to PLC.

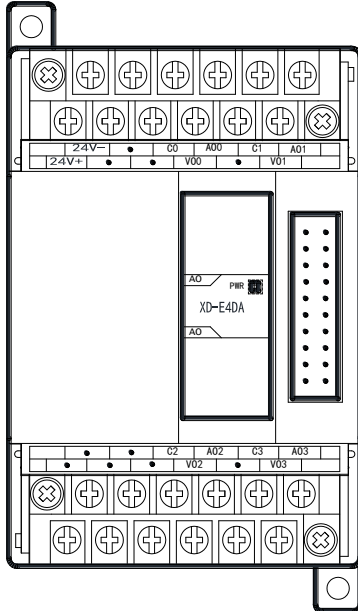

- 4 channels voltage output (0~5V/0 ~10V), current output (0~20mA/4 ~20 mA) for choice.
- Up to 10 modules can be connected to the XD3 series PLC
- Up to 16 modules can be connected to XDM series PLC

Items	Voltage output	Current output
Analog output	DC 0 to 5V, 0 to 10V (external load resistor 2K Ω ~1M Ω)	DC 0 to 20mA, 4 to 20mA (external load resistor is less than 500 Ω)
Digital input	12 bits binary value (0~4095)	
Resolution	1/4095(12 bit)	
General precision	1%	
Conversion speed	2ms per channel	
Power supply for analog using	DC24V \pm 10%,150mA	
Installation	Fix with M3 screws or install on DIN46277 (width: 35) leader directly	
Dimension	63mm \times 108mm \times 79.9mm	

12-2. Terminals

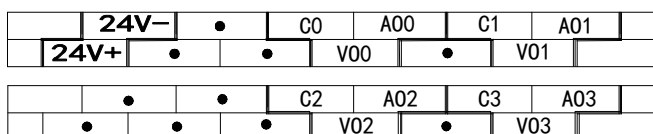

Channel	Terminal name	Signal name
CH0	AO0	Current output
	VO0	Voltage output
	C0	CH0 common terminal
CH1	AO1	Current output
	VO1	Voltage output
	C1	CH1 common terminal
CH2	AO2	Current output
	VO2	Voltage output
	C2	CH2 common terminal
CH3	AO3	Current output
	VO3	Voltage output
	C3	CH3 common terminal
-	24V+	+24V power supply
	24V-	Common terminal of power supply

12-3. I/O address assignment

XD series analog modules don't occupy I/O units, the converted value is sent to PLC register directly. The PLC registers are shown as the following:

Expansion module no.1

Channel	DA signal	Channel enable bit (set on this bit to use this channel)
0CH	QD10000	Y10000
1CH	QD10001	Y10001
2CH	QD10002	Y10002
3CH	QD10003	Y10003

Expansion module no.2

Channel	DA signal	Channel enable bit (set on this bit to use this channel)
0CH	QD10100	Y10100
1CH	QD10101	Y10101
2CH	QD10102	Y10102
3CH	QD10103	Y10103

Expansion module no.3

Channel	DA signal	Channel enable bit (set on this bit to use this channel)
0CH	QD10200	Y10200
1CH	QD10201	Y10201
2CH	QD10202	Y10202
3CH	QD10203	Y10203

Expansion module no.4

Channel	DA signal	Channel enable bit (set on this bit to use this channel)
0CH	QD10300	Y10300
1CH	QD10301	Y10301
2CH	QD10302	Y10302
3CH	QD10303	Y10303

Expansion module no.5

Channel	DA signal	Channel enable bit (set on this bit to use this channel)
0CH	QD10400	Y10400
1CH	QD10401	Y10401
2CH	QD10402	Y10402
3CH	QD10403	Y10403

Expansion module no.6

Channel	DA signal	Channel enable bit (set on this bit to use this channel)
0CH	QD10500	Y10500
1CH	QD10501	Y10501
2CH	QD10502	Y10502
3CH	QD10503	Y10503

Expansion module no.7

Channel	DA signal	Channel enable bit (set on this bit to use this channel)
0CH	QD10600	Y10600
1CH	QD10601	Y10601
2CH	QD10602	Y10602

3CH	QD10603	Y10603
-----	---------	--------

Expansion module no.8

Channel	DA signal	Channel enable bit (set on this bit to use this channel)
0CH	QD10700	Y10700
1CH	QD10701	Y10701
2CH	QD10702	Y10702
3CH	QD10703	Y10703

Expansion module no.9

Channel	DA signal	Channel enable bit (set on this bit to use this channel)
0CH	QD10800	Y11000
1CH	QD10801	Y11001
2CH	QD10802	Y11002
3CH	QD10803	Y11003

Expansion module no.10

Channel	DA signal	Channel enable bit (set on this bit to use this channel)
0CH	QD10900	Y11100
1CH	QD10901	Y11101
2CH	QD10902	Y11102
3CH	QD10903	Y11103

Expansion module no.11

Channel	DA signal	Channel enable bit (set on this bit to use this channel)
0CH	QD11000	Y11200
1CH	QD11001	Y11201
2CH	QD11002	Y11202
3CH	QD11003	Y11203

Expansion module no.12

Channel	DA signal	Channel enable bit (set on this bit to use this channel)
0CH	QD11100	Y11300

1CH	QD11101	Y11301
2CH	QD11102	Y11302
3CH	QD11103	Y11303

Expansion module no.13

Channel	DA signal	Channel enable bit (set on this bit to use this channel)
0CH	QD11200	Y11400
1CH	QD11201	Y11401
2CH	QD11202	Y11402
3CH	QD11203	Y11403

Expansion module no.14

Channel	DA signal	Channel enable bit (set on this bit to use this channel)
0CH	QD11300	Y11500
1CH	QD11301	Y11501
2CH	QD11302	Y11502
3CH	QD11303	Y11503

Expansion module no.15

Channel	DA signal	Channel enable bit (set on this bit to use this channel)
0CH	QD11400	Y11600
1CH	QD11401	Y11601
2CH	QD11402	Y11602
3CH	QD11403	Y11603

Expansion module no.16

Channel	DA signal	Channel enable bit (set on this bit to use this channel)
0CH	QD11500	Y11700
1CH	QD11501	Y11701
2CH	QD11502	Y11702
3CH	QD11503	Y11703

Note:

1. Forbid the unused channel to improve the I/O scanning speed.

2. If set off the enable bit of the output channel, this channel will keep the present value.

12-4. Working mode

There are two ways to set the working mode:

1. XDPpro software
2. Flash registers of PLC

XDPpro software:

Open the XDPpro software, click configure/expansion module settings:

Set the model and channel parameters in the following window. Then click write to PLC.

Please restart the PLC after setting.

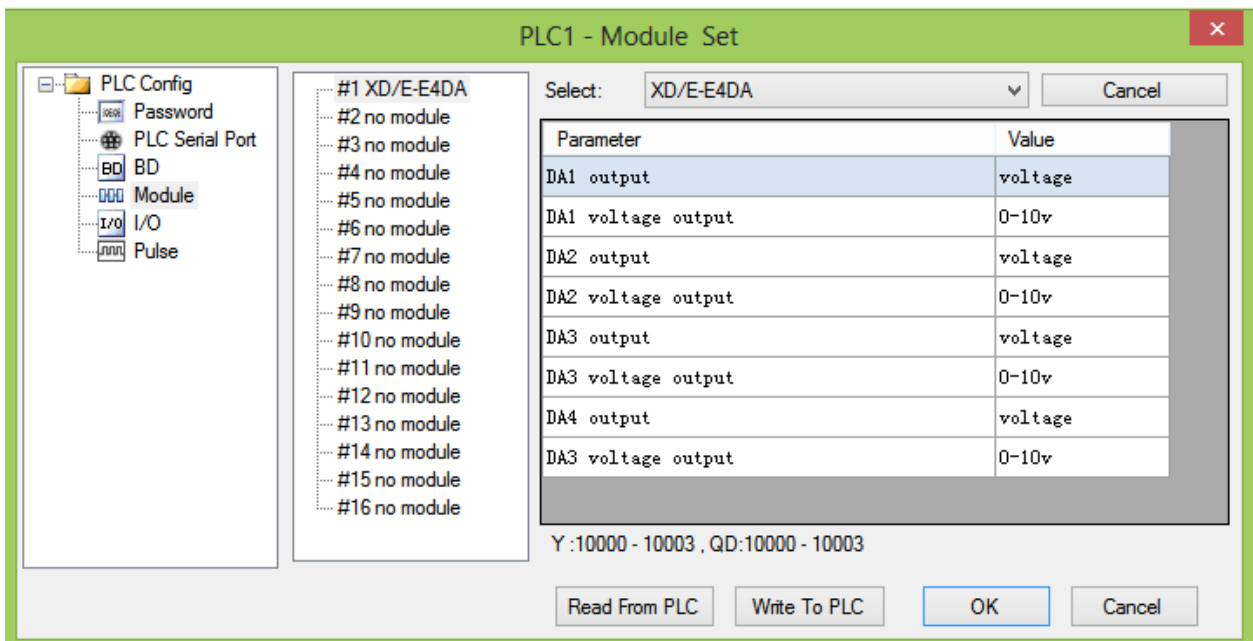

Note: first-order low-pass filter will weighted present sampling value with last time filter output to get the final filter value. The filter factor range is 0 to 255, the default value is 0 which means no filter.

Flash registers:

The module output has voltage 0 ~ 5V, 0 ~ 10V, current 0 ~ 20mA, 4 ~ 20mA, set the modes through the PLC FLASH registers SFD.

Module no.	SFD address	Module no.	SFD address
#1	SFD350~SFD359	#9	SFD430~SFD439
#2	SFD360~SFD369	#10	SFD440~SFD449

#3	SFD370~SFD379	#11	SFD450~SFD459
#4	SFD380~SFD389	#12	SFD460~SFD469
#5	SFD390~SFD399	#13	SFD470~SFD479
#6	SFD400~SFD409	#14	SFD480~SFD489
#7	SFD410~SFD419	#15	SFD490~SFD499
#8	SFD420~SFD429	#16	SFD500~SFD509

SFD bit definition:

Expansion module no.1:

	Bit7	Bit6	Bit5	Bit4	Bit3	Bit2	Bit1	Bit0	Explanation
	DA2				DA1				To define the DA output range. Byte0 low 4 bits are DA channel 1, high 4 bits are DA channel 2. Byte1 low 4 bits are DA channel 3, high 4 bits are DA channel 4.
Byte0	-	-	0: voltage output 1: current output	0 : 0~10V 1 : 0~5V 0 : 0~20mA 1 : 4~20mA	-	-	0: voltage output 1: current output	0:0~10V 1:0~5V 0:0~20mA 1:4~20mA	
	DA4				DA3				
Byte1	-	-	0: voltage output 1: current output	0 : 0~10V 1 : 0~5V 0 : 0~20mA 1 : 4~20mA	-	-	0: voltage output 1: current output	0:0~10V 1:0~5V 0:0~20mA 1:4~20mA	
Byte2 ~ Byte19	-								

For example:

Set channel 4, 3, 2, 1 working mode to 0~10V, 0~10V, 0~20mA, 0~20mA.

The SFD values are: SFD350=0022H.

12-5. External connection

When make external connection, please note the following items:

- When connect to external +24V power supply, please use 24V power supply of PLC to avoid interference.
- To avoid interference, please use shield cable, and single-point ground with the shield layer.

Voltage output:

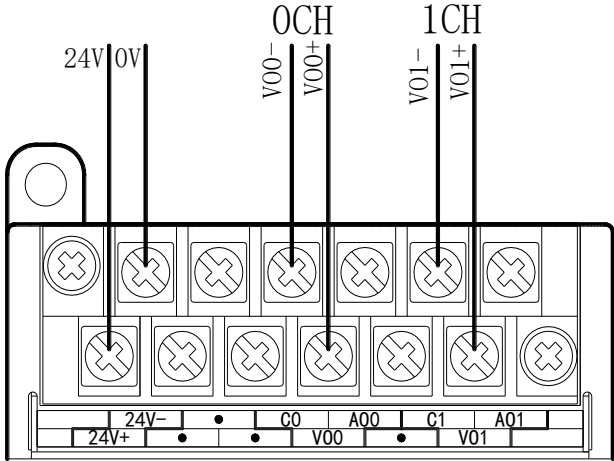

Current output:

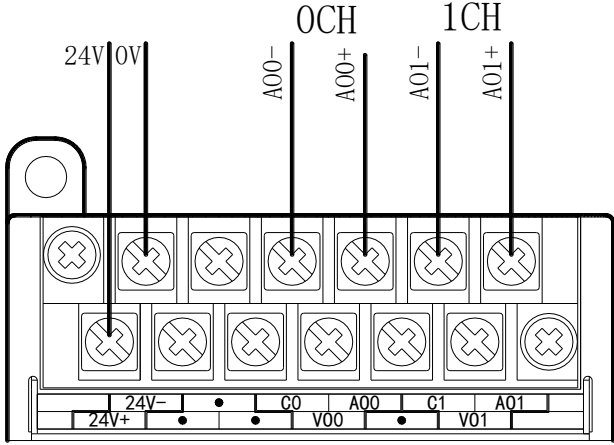

XD-E4DA current output wiring:

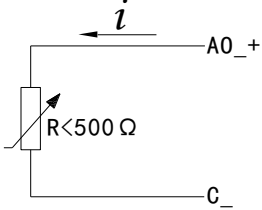

12-6. DA conversion diagram

The relationship between digital input value and analog output value is shown as below:

When the input value is larger than 4095, D/A converted analog value will remain 5V, 10V or 20mA.

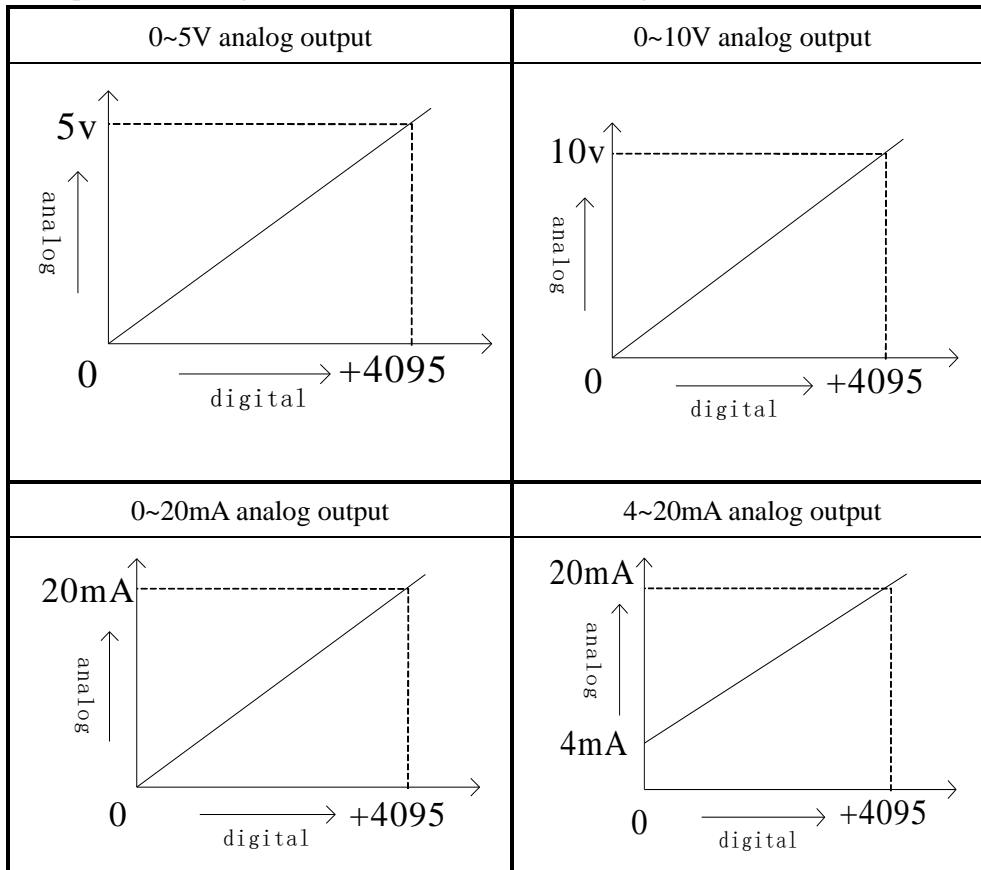

12-7. Programming

Real-time write data to 4 channels (take expansion module no.1 as an example)

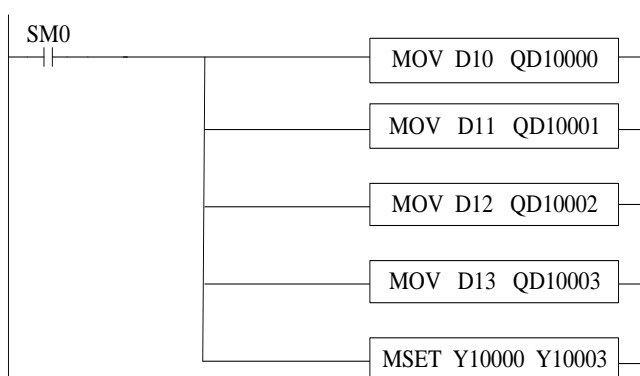

Write the value of D10 to channel 0

Write the value of D11 to channel 1

Write the value of D12 to channel 2

Write the value of D13 to channel 3

Set ON all the channel enable bits.

13. 4 channels pressure module XD-E4WT-A

13-1. Features

XD-E4WT-A is the expansion module of XD series PLC. It can test the voltage in the range of 0~39.06mV or the voltage signal from pressure sensor. Then it can transform the voltage to digital value through A/D transformation and do calculation.

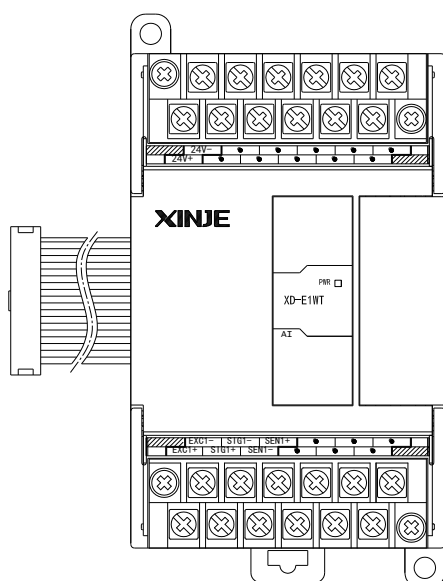

- 4 channels pressure sensor voltage signal input
- Test voltage signal in the range of 0~39.06mV
- 24-bit A/D transformation
- XD3 series PLC can connect 10 XD-E4WT-A modules
- XDM series PLC can connect 16 XD-E4WT-A modules

Input range	DC 0~39.06mV
Resolution	1/8388608 (24Bit)
Integrated precision	0.1%
Transformation speed	0-250 times/second
Power supply	DC24V ±10%, 100mA
Sensor power supply	5VDC/120mA, can parallel 4 pieces of 350Ω pressure sensor
Installation	Mount on DIN46277 rail (width 35mm) or fix with screw M3
Software version	V3.2 and higher version
Working environment	No corrosive gas
Ambient temperature	0°C~60°C
Humidity	5~95%

13-2. Terminals

	24V-	EXC2-	SIG3-	SEN3-	SIG4-	SEN4-	
	24V+	EXC2+	SIG3+	SEN3+	SIG4+	SEN4+	
	EXC1-	SIG1-	SEN1-	SIG2-	SEN2-	●	
	EXC1+	SIG1+	SEN1+	SIG2+	SEN2+	SH1	

Channel	Terminal	Signal	Meaning
CH1	EXC1+	Excitation +	Connect to sensor power supply input
	EXC1-	Excitation -	
	SIG1+	Signal +	Connect to sensor signal output
	SIG1-	Signal -	
	SEN1+	Feedback +	Connect to sensor feedback voltage output
	SEN1-	Feedback -	
CH2	EXC1+	Excitation +	Connect to sensor power supply input
	EXC1-	Excitation -	
	SIG2+	Signal +	Connect to sensor signal output
	SIG2-	Signal -	
	SEN2+	Feedback +	Connect to sensor feedback voltage output
	SEN2-	Feedback -	
CH3	EXC2+	Excitation +	Connect to sensor power supply input
	EXC2-	Excitation -	
	SIG3+	Signal +	Connect to sensor signal output
	SIG3-	Signal -	
	SEN3+	Feedback +	Connect to sensor feedback voltage output
	SEN3-	Feedback -	
CH4	EXC2+	Excitation +	Connect to sensor power supply input
	EXC2-	Excitation -	
	SIG4+	Signal +	Connect to sensor signal output
	SIG4-	Signal -	
	SEN4+	Feedback +	Connect to sensor feedback voltage output
	SEN4-	Feedback -	
-	SH1	Shield	Connect to sensor ground terminal
	24V+	+24V power supply	Power supply of module
	24V-	Power supply common terminal	

13-3. External connection

Please use the 24V power supply on the PLC to avoid interference.

Please use shield cable and single-point connect to the ground for shield layer.

Power supply wiring

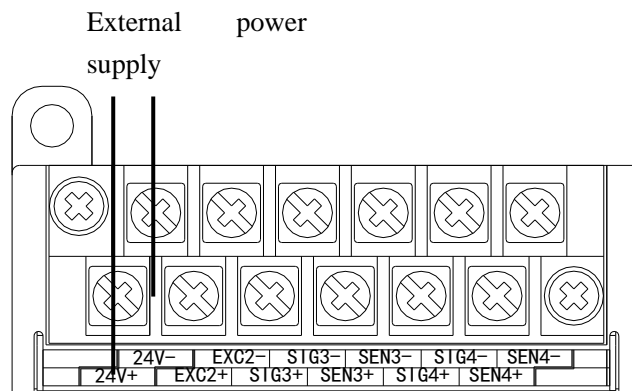

Connect to sensor

6 wires mode:

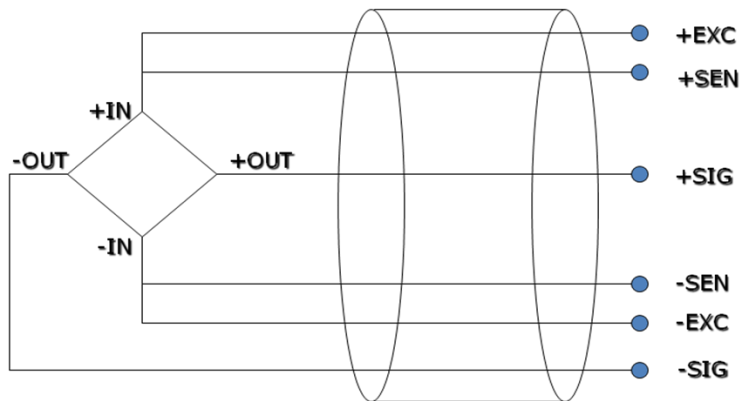

4 wires mode:

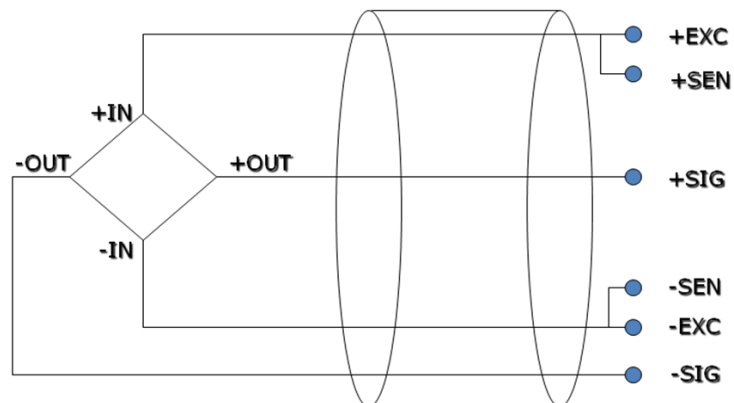

Note: short connect EXC- and SEN-, short connect EXC+ and SEN+ for 4 wires mode.

13-4. Weighing system

A typical weighing system:

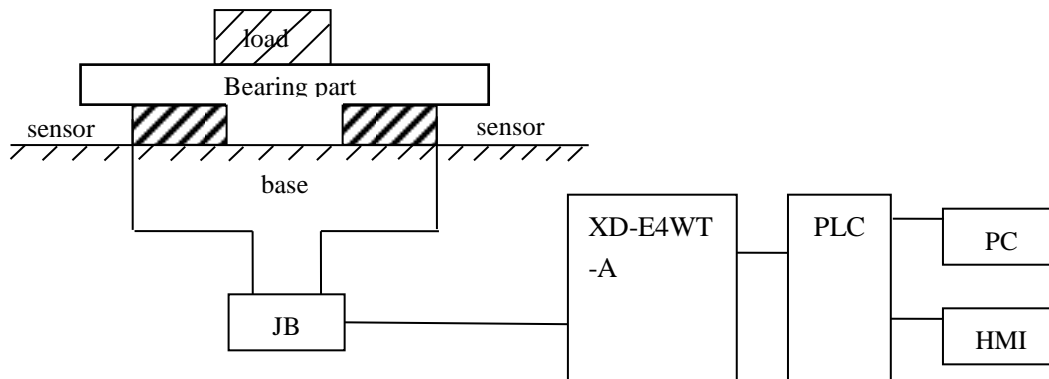

Loading bearing part: to support the load. Such as flat, hopper, container, air transport car...

Pressure sensor: transform the weight to voltage signal.

Assembly part: make sure the pressure sensor can work correctly, assembly part and direct part can avoid overload. Overload will cause measurement error and sensor damage.

Connection box (JB): to collect several sensor signals.

XD-E4WT-A: can be used as an electronic assessment device, it gets the pressure sensor signal and makes further assessment.

13-5. Module functions

XD-E4WT-A has the follow functions:

- Adjust the pressure sensor
- Collect the pressure sensor signal
- Calculate the weight value
- 0~39.06mV voltage signal test

13-5-1. Pressure sensor

The pressure sensor is based on resistance strain effect, see the following diagram:

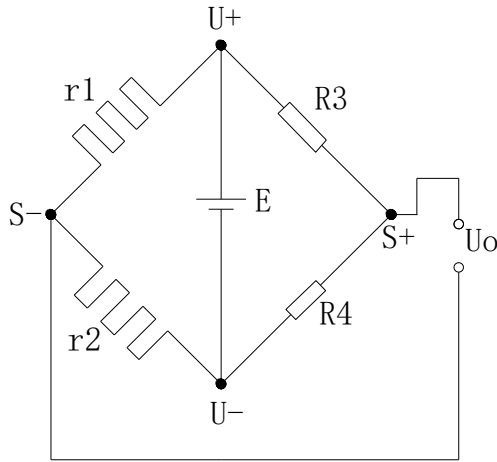

R1 and R2 is strain resistor which make bridge circuit with R3 and R4. With the change of R1 and R2, the bridge circuit will lose the balance, unbalance voltage U_o will be produced as the output of sensor.

U_+ and U_- are positive and negative point of the sensor power supply. Please select the 5V power of the module or from outside.

S_+ and S_- are positive and negative point of the sensor output. Connect the output to the module to test the weight.

13-6. I/O address

The I/O address of module 1:

Soft component		Address	Explanation	Mark
Output coil	CH1	Y10000	Fast sampling enable, ON is fast sampling, OFF is slow sampling	
		Y10001	Write in user-defined parameter	
		Y10002	Reset	
		Y10003	Calibration/resonance measurement	
	CH2	Y10004	Fast sampling enable, ON is fast sampling, OFF is slow sampling	
		Y10005	Write in user-defined parameter	
		Y10006	Reset	
		Y10007	Calibration/resonance measurement	
	CH3	Y10010	Fast sampling enable, ON is fast sampling, OFF is slow sampling	
		Y10011	Write in user-defined parameter	
		Y10012	Reset	
	CH4	Y10013	Calibration/resonance measurement	
		Y10014	Fast sampling enable, ON is fast sampling, OFF is slow sampling	
		Y10015	Write in user-defined parameter	
		Y10016	Reset	

		Y10017	Calibration/resonance measurement	
Input coil	CH1	X10000	CH1 resonance frequency measurement complete sign	
	CH2	X10001	CH2 resonance frequency measurement complete sign	
	CH3	X10002	CH3 resonance frequency measurement complete sign	
	CH4	X10003	CH4 resonance frequency measurement complete sign	
Input register	CH1	ID10000	Present digital value	Dword
		ID10002	Present weight	Dword
	CH2	ID10004	Present digital value	Dword
		ID10006	Present weight	Dword
	CH3	ID10008	Present digital value	Dword
		ID10010	Present weight	Dword
	CH4	ID10012	Present digital value	Dword
		ID10014	Present weight	Dword

The I/O address of module 2:

Soft component		Address	Explanation	Mark
Output coil	CH1	Y10100	Fast sampling enable, ON is fast sampling, OFF is slow sampling	
		Y10101	Write in user-defined parameter	
		Y10102	Reset	
		Y10103	Calibration/resonance measurement	
	CH2	Y10104	Fast sampling enable, ON is fast sampling, OFF is slow sampling	
		Y10105	Write in user-defined parameter	
		Y10106	Reset	
		Y10107	Calibration/resonance measurement	
	CH3	Y10110	Fast sampling enable, ON is fast sampling, OFF is slow sampling	
		Y10111	Write in user-defined parameter	
		Y10112	Reset	
		Y10113	Calibration/resonance measurement	
	CH4	Y10114	Fast sampling enable, ON is fast sampling, OFF is slow sampling	
		Y10115	Write in user-defined parameter	
		Y10116	Reset	
		Y10117	Calibration/resonance measurement	
Input coil	CH1	X10100	CH1 resonance frequency measurement complete sign	
	CH2	X10101	CH2 resonance frequency measurement complete sign	
	CH3	X10102	CH3 resonance frequency measurement complete sign	
	CH4	X10103	CH4 resonance frequency measurement complete sign	
	CH1	ID10100	Present digital value	Dword

Input register	CH2	ID10102	Present weight	Dword
		ID10104	Present digital value	Dword
	CH3	ID10106	Present weight	Dword
		ID10108	Present digital value	Dword
	CH4	ID10110	Present weight	Dword
		ID10112	Present digital value	Dword
		ID10114	Present weight	Dword

.....

The I/O address of module 16:

Soft component		Address	Explanation	Mark
Output coil	CH1	Y11500	Fast sampling enable, ON is fast sampling, OFF is slow sampling	
		Y11501	Write in user-defined parameter	
		Y11502	Reset	
		Y11503	Calibration/resonance measurement	
	CH2	Y11504	Fast sampling enable, ON is fast sampling, OFF is slow sampling	
		Y11505	Write in user-defined parameter	
		Y11506	Reset	
		Y11507	Calibration/resonance measurement	
	CH3	Y11510	Fast sampling enable, ON is fast sampling, OFF is slow sampling	
		Y11511	Write in user-defined parameter	
		Y11512	Reset	
		Y11513	Calibration/resonance measurement	
	CH4	Y11514	Fast sampling enable, ON is fast sampling, OFF is slow sampling	
		Y11515	Write in user-defined parameter	
		Y11516	Reset	
		Y11517	Calibration/resonance measurement	
Input coil	CH1	X11500	CH1 resonance frequency measurement complete sign	
	CH2	X11501	CH2 resonance frequency measurement complete sign	
	CH3	X11502	CH3 resonance frequency measurement complete sign	
	CH4	X11503	CH4 resonance frequency measurement complete sign	
CH1	ID11500	Present digital value	Dword	
	ID11502	Present weight	Dword	

Input register	CH2	ID11504	Present digital value	Dword
		ID11506	Present weight	Dword
	CH3	ID11508	Present digital value	Dword
		ID11510	Present weight	Dword
	CH4	ID11512	Present digital value	Dword
		ID11514	Present weight	Dword

13-7. Working mode

There are two method to set the working mode:

1. set through the control panel
2. set through Flash register

Open the XD PLC software, click the menu configure/expansion module setting.

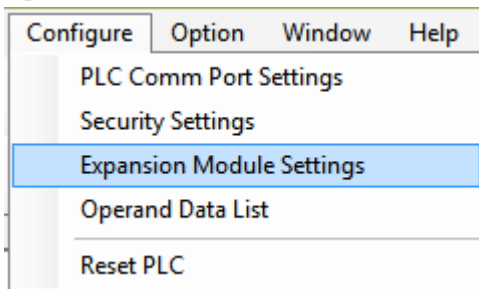

Choose the correct model and configuration information:

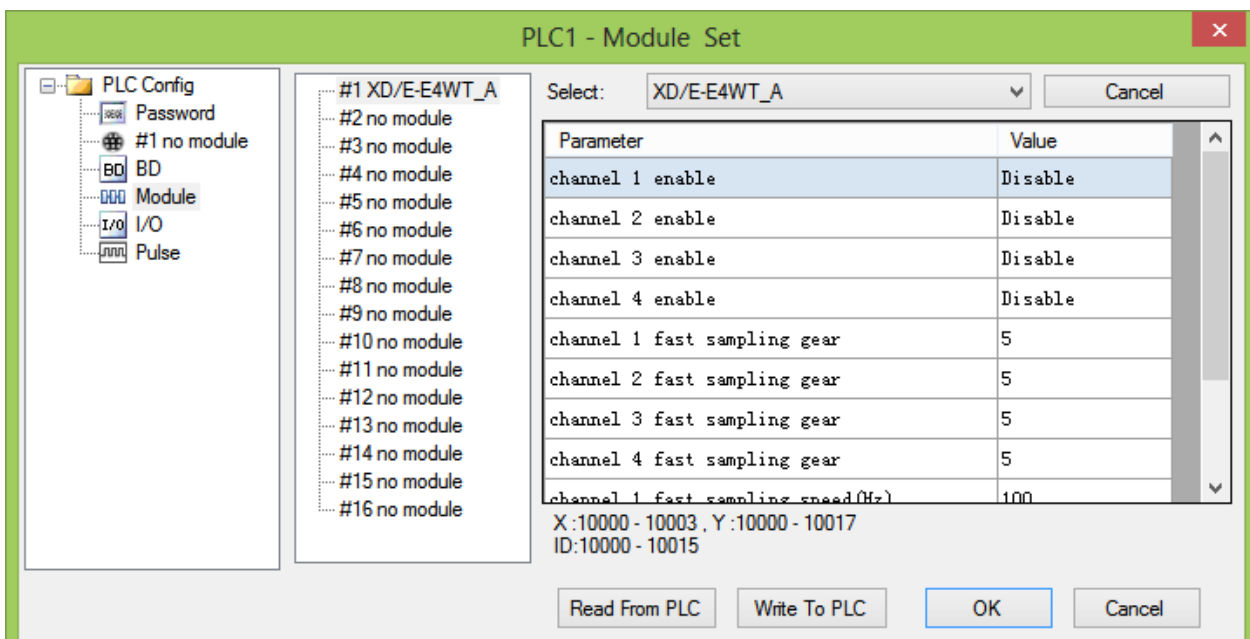

Flash register setting:

The expansion module can set the gear and user-defined fast sampling frequency through PLC flash register

SFD.

Module no.	SFD address	Module no.	SFD address
#1	SFD350~SFD359	#9	SFD430~SFD439
#2	SFD360~SFD369	#10	SFD440~SFD449
#3	SFD370~SFD379	#11	SFD450~SFD459
#4	SFD380~SFD389	#12	SFD460~SFD469
#5	SFD390~SFD399	#13	SFD470~SFD479
#6	SFD400~SFD409	#14	SFD480~SFD489
#7	SFD410~SFD419	#15	SFD490~SFD499
#8	SFD420~SFD429	#16	SFD500~SFD509

SFD350~SFD359 register explanation:

SFD		Bit7	Bit6	Bit5	Bit4	Bit3	Bit2	Bit1	Bit0	Explanation	
SFD350	Byte0	CH4 enable	CH3 enable	CH2 enable	CH1 enable					Slow sampling default speed is 5Hz, fast sampling has 15 user-defined speed gears	
	Byte1	CH2 fast sampling speed gear (0-15)				CH1 fast sampling speed gear (0-15)					
SFD351	Byte2	CH4 fast sampling speed gear (0-15)				CH3 fast sampling speed gear (0-15)					
	Byte3	CH1 user-defined fast sampling speed (Hz) (10-255)									
SFD352	Byte4	CH2 user-defined fast sampling speed (Hz) (10-255)									
	Byte5	CH3 user-defined fast sampling speed (Hz) (10-255)									
SFD353	Byte6	CH4 user-defined fast sampling speed (Hz) (10-255)									
	Byte7										
SFD354	Byte8										
	Byte9										
SFD355	Byte10										
	Byte11										
SFD356	Byte12										
	Byte13										
SFD357	Byte14										

	Byte15		
SFD358	Byte16		
	Byte17		
SFD359	Byte18		
	Byte19		

13-8. Module setting

Take module no.1 as an example:

Weight unit setting:

Write in weight through instruction TO. For example, the object weight is 1kg, write in 1 means the unit is kg, write in 1000 means the unit is g, write in 10000 means the unit is 0.1g.

Sampling frequency:

Sampling frequency includes fast sampling and slow sampling. The two states can be switched through Y10003. The default frequency of slow sampling is 5Hz. The fast sampling has 15 gears which can be selected in PLC expansion module configuration table. Each gear from 0 to 14 has different sampling frequency and filter parameters. User can choose suitable gear as actual needs, please refer to default gear parameter table. Gear 15 is user-defined mode, it can set the sampling frequency and filter parameter by user. User can set the fast sampling frequency (this parameter is invalid for other gears) by software and set the filter parameter by instruction FROM and TO.

Resonance frequency measurement:

1. resonance frequency is the fixed vibration interference generated by machine, it will be tested when installing the machine at the beginning.
2. repower on the module or write in 0 for the weight by instruction FROM and TO.
3. switch to fast sampling mode (Y10000 is ON), set on Y10003. The module will enter resonance frequency measurement. Then set OFF Y10003. X10000 will be ON when the measurement completed. The result will be automatic saved in the module. (it is necessary to test the resonance frequency in fast sampling mode)

Calibration:

Please calibrate the pressure sensor for the first time using.

Take module channel 1 as an example:

1. make sure the module connected to the weighting system. Please check if the value in ID10000 fluctuated(the fluctuation range is related to sensor range), the pressure value is increasing as the load increasing. If ID10000 has no value, please check the sensor wiring. If the pressure value is decreasing as the load increasing, the sensor positive and negative point may connect backward.
2. close fast sampling enable bit Y10000 before calibration.
3. make the pressure sensor without load, set to zero after the scale is stable, set ON Y10002(set to zero enable bit).
4. put the load on the scale, write in the load weight by instruction TO, calibrate the system after the scale is stable, set ON Y10003(calibration enable bit). The calibration completed when ID10002 is same to the load

weight, set OFF Y10003.

5. Hereto, the calibration finished. The module will automatic adjust the result according to the idle load value and calibration value when weighing, and finally get the correct weight.

Default gear parameter:

Speed gear	Fast sampling speed (Hz)	Fast sampling filter width	Kalman filter depth	IIR bandwidth coefficient	IIR attenuation ratio coefficient	Lowpass cut-off frequency
0	60	5	30	10	10	10
1	80	5	40	10	10	10
2	100	10	50	10	10	10
3	120	10	60	10	10	10
4	140	15	70	10	10	15
5	160	15	80	10	10	15
6	180	20	90	10	10	15
7	200	20	100	10	10	15
8	220	25	110	10	10	15
9	240	25	120	10	10	15
10	250	25	125	10	10	15
11	250	25	125	10	10	15
12	250	25	125	10	10	15
13	250	25	125	10	10	15
14	255	25	125	10	10	15

13-9. Instruction FROM and TO

Write instruction TO

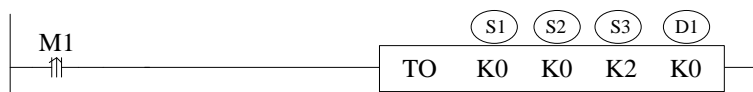

Function: write the PLC register data to module specified address, the unit is word.

Operand:

S1: target module number. Operand: K, TD, CD, D, FD.

S2: module first address. Operand: K, TD, CD, D, FD.

S3: write in register quantity. Operand: K, TD, CD, D, FD.

D1: write in data first address in PLC.

Read instruction FROM

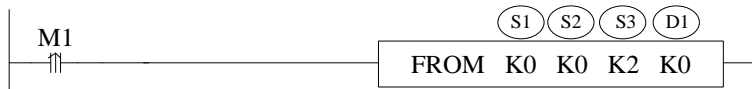

Function: read the module data to PLC register, the unit is word.

Operand:

S1: target module number. Operand: K, TD, CD, D, FD.

S2: module first address. Operand: K, TD, CD, D, FD.

S3: read register quantity. operand: K, TD, CD, D, FD.

D1: PLC register first address.

Module parameter internal address:

From/ToData		
K0	CH1 calibration weight	Dword
K2	CH1 fast sampling filter width	Word
K3	CH1 filter depth	Word
K4	CH1 bandwidth coefficient	Word
K5	CH1 attenuation coefficient	Word
K6	CH1 low pass cutoff frequency	Word
K7	CH1 resonance frequency (0.1HZ)	Word
K8	CH2 calibration weight	Dword
K10	CH2 fast sampling filter width	Word
K11	CH2 filter depth	Word
K12	CH2 bandwidth coefficient	Word
K13	CH2 attenuation coefficient	Word
K14	CH2 low pass cutoff frequency	Word
K15	CH2 resonance frequency (0.1HZ)	Word
K16	CH3 calibration weight	Dword
K18	CH3 fast sampling filter width	Word
K19	CH3 filter depth	Word
K20	CH3 bandwidth coefficient	Word
K21	CH3 attenuation coefficient	Word
K22	CH3 low pass cutoff frequency	Word
K23	CH3 resonance frequency (0.1HZ)	Word
K24	CH4 calibration weight	Dword
K26	CH4 fast sampling filter width	Word
K27	CH4 filter depth	Word
K28	CH4 bandwidth coefficient	Word
K29	CH4 attenuation coefficient	Word
K30	CH4 low pass cutoff frequency	Word
K31	CH4 resonance frequency (0.1HZ)	Word

Parameter explanation:

1. calibration weight: write in weight when calibrating
2. fast sampling filter width: the average times of fast sampling filter
3. attenuation coefficient: the larger the more stable, but too large will make the sampling value distortion and sensitivity reduction.
4. bandwidth coefficient: the larger the more stable, but too large will make the sampling value distortion and sensitivity reduction.
5. resonance frequency: the scale has natural frequency, this frequency can be known by internal measurement. The more accurate of the frequency, the better the filtering effect.
6. Filter depth: the larger the data, more stable the system, the lower the sensitivity.

13-10. A/D transformation diagram

The relationship between input voltage value and A/D transformed digital value:

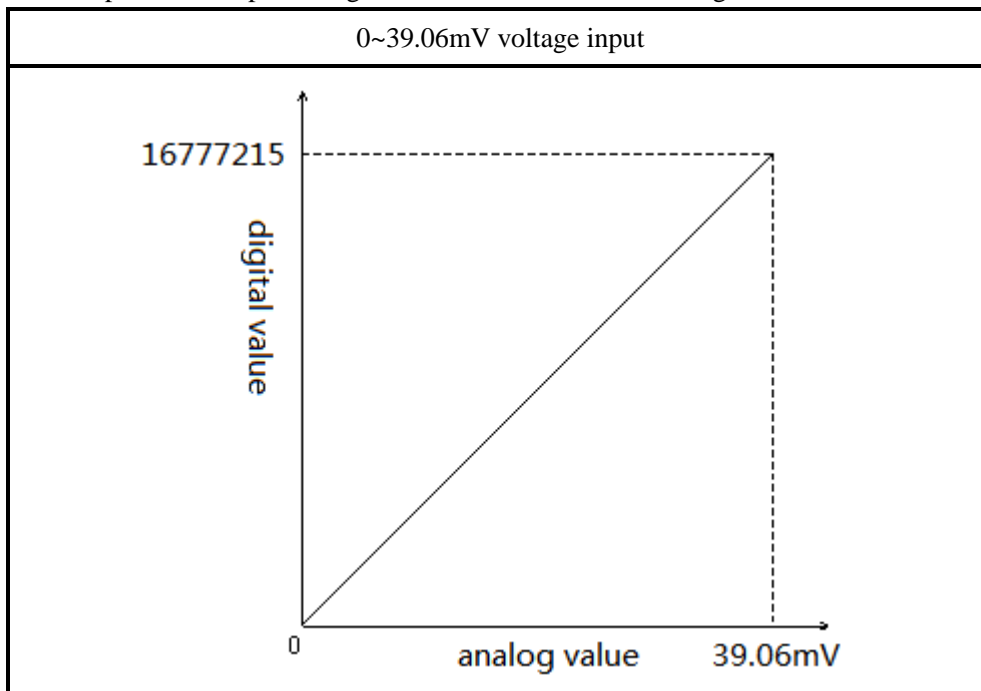

13-11. Application program

Take module 1 as an example:

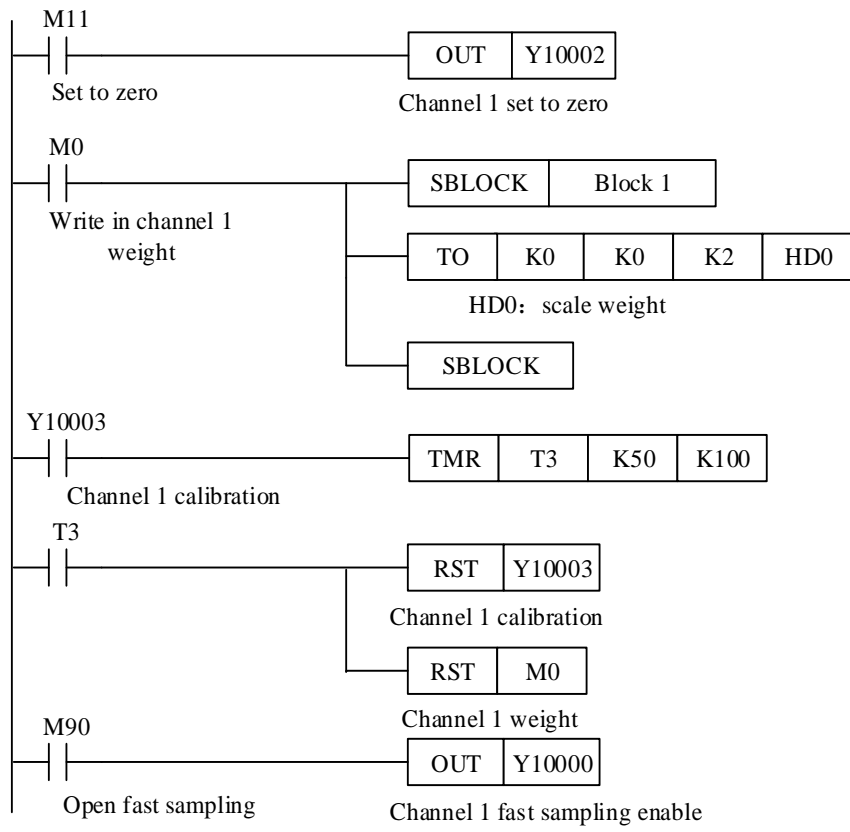

Explanation:

Set to zero through Y10002.

Write in the weight value through instruction TO. First send the weight value in HD0, set ON M0, write the value of HD0 to module 1 channel 1.

Put the load, calibrate the scale through Y10003. The calibration is finished when the weight value is equal to the weight display value.

Switch the slow or fast sampling through Y10000.

Y10000 open, channel 1 will collect data with fast sampling frequency.

Y10000 close, channel 1 will collect data with slow sampling frequency.

14. Analog input module XD-E8AD-A

14-1. Specification

XD-E8AD-A transform the analog value (current input) to digital value and send to PLC registers.

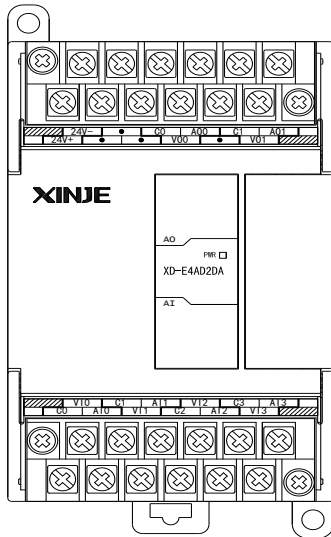

- 14 bits high precision analog input
- 8 channels current input
- The power supply of analog and digital part is isolated
- As special function module of XD3, up to 10 models can be connected.
- XDM can connect 16 modules

Items	Current input
Analog input range	0~20mA, 4~20mA, -20~20mA
Max input range	0~40mA
Digital output range	14 bits binary data (0~16383)
PID control value	0~4095
Resolution	1/16383(14Bit)
Integrate Precision	1%
Conversion speed	2ms per channel
Analog power supply	DC24V ±10%, 150mA
Installation	Can be fixed with screw M3 or directly installed on orbit of DIN46277 (width: 35mm)
Dimension	63mm×108mm×79.9mm

14-2. Terminals

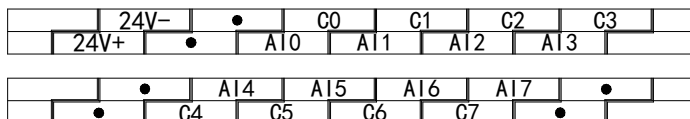

Channel	Terminal name	Signal name
CH0	AI0	Current input
	C0	CH0 input common terminal
CH1	AI1	Current input
	C1	CH1 input common terminal
CH2	AI2	Current input
	C2	CH2 input common terminal
CH3	AI3	Current input
	C3	CH3 input common terminal
CH4	AI4	Current input
	C4	CH4 input common terminal
CH5	AI5	Current input
	C5	CH5 input common terminal
CH6	AI6	Current input
	C6	CH6 input common terminal
CH7	AI7	Current input
	C7	CH7 input common terminal
-	24V+	+24V power supply
	24V-	Common terminal of power supply

14-3. I/O distribution

XD series analog expansion modules don't occupy I/O unit, the converted data is directly transferred to PLC register. Each channel address:

I/O address list

Register address of expansion module 1:

Channel	AD signal	Channel enable (set ON the enable bit to use this channel)
0CH	ID10000	Y10000
1CH	ID10001	Y10001
2CH	ID10002	Y10002
3CH	ID10003	Y10003
4CH	ID10004	Y10004

5CH	ID10005	Y10005
6CH	ID10006	Y10006
7CH	ID10007	Y10007

Register address of expansion module 2:

Channel	AD signal	Channel enable (set ON the enable bit to use this channel)
0CH	ID10100	Y10100
1CH	ID10101	Y10101
2CH	ID10102	Y10102
3CH	ID10103	Y10103
4CH	ID10104	Y10104
5CH	ID10105	Y10105
6CH	ID10106	Y10106
7CH	ID10107	Y10107

Register address of expansion module 3:

Channel	AD signal	Channel enable (set ON the enable bit to use this channel)
0CH	ID10200	Y10200
1CH	ID10201	Y10201
2CH	ID10202	Y10202
3CH	ID10203	Y10203
4CH	ID10204	Y10204
5CH	ID10205	Y10205
6CH	ID10206	Y10206
7CH	ID10207	Y10207

Register address of expansion module 4:

Channel	AD signal	Channel enable (set ON the enable bit to use this channel)
0CH	ID10300	Y10300
1CH	ID10301	Y10301
2CH	ID10302	Y10302

3CH	ID10303	Y10303
4CH	ID10304	Y10304
5CH	ID10305	Y10305
6CH	ID10306	Y10306
7CH	ID10307	Y10307

Register address of expansion module 5:

Channel	AD signal	Channel enable (set ON the enable bit to use this channel)
0CH	ID10400	Y10400
1CH	ID10401	Y10401
2CH	ID10402	Y10402
3CH	ID10403	Y10403
4CH	ID10404	Y10404
5CH	ID10405	Y10405
6CH	ID10406	Y10406
7CH	ID10407	Y10407

Register address of expansion module 6:

Channel	AD signal	Channel enable (set ON the enable bit to use this channel)
0CH	ID10500	Y10500
1CH	ID10501	Y10501
2CH	ID10502	Y10502
3CH	ID10503	Y10503
4CH	ID10504	Y10504
5CH	ID10505	Y10505
6CH	ID10506	Y10506
7CH	ID10507	Y10507

Register address of expansion module 7:

Channel	AD signal	Channel enable (set ON the enable bit to use this channel)
0CH	ID10600	Y10600
1CH	ID10601	Y10601

2CH	ID10602	Y10602
3CH	ID10603	Y10603
4CH	ID10604	Y10604
5CH	ID10605	Y10605
6CH	ID10606	Y10606
7CH	ID10607	Y10607

Register address of expansion module 8:

Channel	AD signal	Channel enable (set ON the enable bit to use this channel)
0CH	ID10700	Y10700
1CH	ID10701	Y10701
2CH	ID10702	Y10702
3CH	ID10703	Y10703
4CH	ID10704	Y10704
5CH	ID10705	Y10705
6CH	ID10706	Y10706
7CH	ID10707	Y10707

Register address of expansion module 9:

Channel	AD signal	Channel enable (set ON the enable bit to use this channel)
0CH	ID10800	Y11000
1CH	ID10801	Y11001
2CH	ID10802	Y11002
3CH	ID10803	Y11003
4CH	ID10804	Y11004
5CH	ID10805	Y11005
6CH	ID10806	Y11006
7CH	ID10807	Y11007

Register address of expansion module 10:

Channel	AD signal	Channel enable (set ON the enable bit to use this channel)
0CH	ID10900	Y11100

1CH	ID10901	Y11101
2CH	ID10902	Y11102
3CH	ID10903	Y11103
4CH	ID10904	Y11104
5CH	ID10905	Y11105
6CH	ID10906	Y11106
7CH	ID10907	Y11107

Register address of expansion module 11:

Channel	AD signal	Channel enable (set ON the enable bit to use this channel)
0CH	ID11000	Y11200
1CH	ID11001	Y11201
2CH	ID11002	Y11202
3CH	ID11003	Y11203
4CH	ID11004	Y11204
5CH	ID11005	Y11205
6CH	ID11006	Y11206
7CH	ID11007	Y11207

Register address of expansion module 12:

Channel	AD signal	Channel enable (set ON the enable bit to use this channel)
0CH	ID11100	Y11300
1CH	ID11101	Y11301
2CH	ID11102	Y11302
3CH	ID11103	Y11303
4CH	ID11104	Y11304
5CH	ID11105	Y11305
6CH	ID11106	Y11306
7CH	ID11107	Y11307

Register address of expansion module 13:

Channel	AD signal	Channel enable (set ON the enable bit to use this channel)
0CH	ID11200	Y11400
1CH	ID11201	Y11401
2CH	ID11202	Y11402
3CH	ID11203	Y11403
4CH	ID11204	Y11404
5CH	ID11205	Y11405
6CH	ID11206	Y11406
7CH	ID11207	Y11407

Register address of expansion module 14:

Channel	AD signal	Channel enable (set ON the enable bit to use this channel)
0CH	ID11300	Y11500
1CH	ID11301	Y11501
2CH	ID11302	Y11502
3CH	ID11303	Y11503
4CH	ID11304	Y11504
5CH	ID11305	Y11505
6CH	ID11306	Y11506
7CH	ID11307	Y11507

Register address of expansion module 15:

Channel	AD signal	Channel enable (set ON the enable bit to use this channel)
0CH	ID11400	Y11600
1CH	ID11401	Y11601
2CH	ID11402	Y11602
3CH	ID11403	Y11603
4CH	ID11404	Y11604
5CH	ID11405	Y11605

6CH	ID11406	Y11606
7CH	ID11407	Y11607

Register address of expansion module 16:

Channel	AD signal	Channel enable (set ON the enable bit to use this channel)
0CH	ID11500	Y11700
1CH	ID11501	Y11701
2CH	ID11502	Y11702
3CH	ID11503	Y11703
4CH	ID11504	Y11704
5CH	ID11505	Y11705
6CH	ID11506	Y11706
7CH	ID11507	Y11707

Note:

3. Forbid the unused channel to improve the I/O scanning speed.
4. If set off the enable bit of the channel, this channel will not accept the data. (the data display is 0).

14-4. Working mode

There are two ways to set the working mode:

1. XDPpro software
2. Flash registers of PLC

XDPpro software:

Open the XDPpro software, click configure/expansion module settings:

Set the model and channel parameters in the following window. Then click write to PLC.

Please restart the PLC after setting.

Note: first-order low-pass filter will weighted present sampling value with last time filter output to get the final filter value. The filter factor range is 0 to 255, the default value is 0 which means no filter.

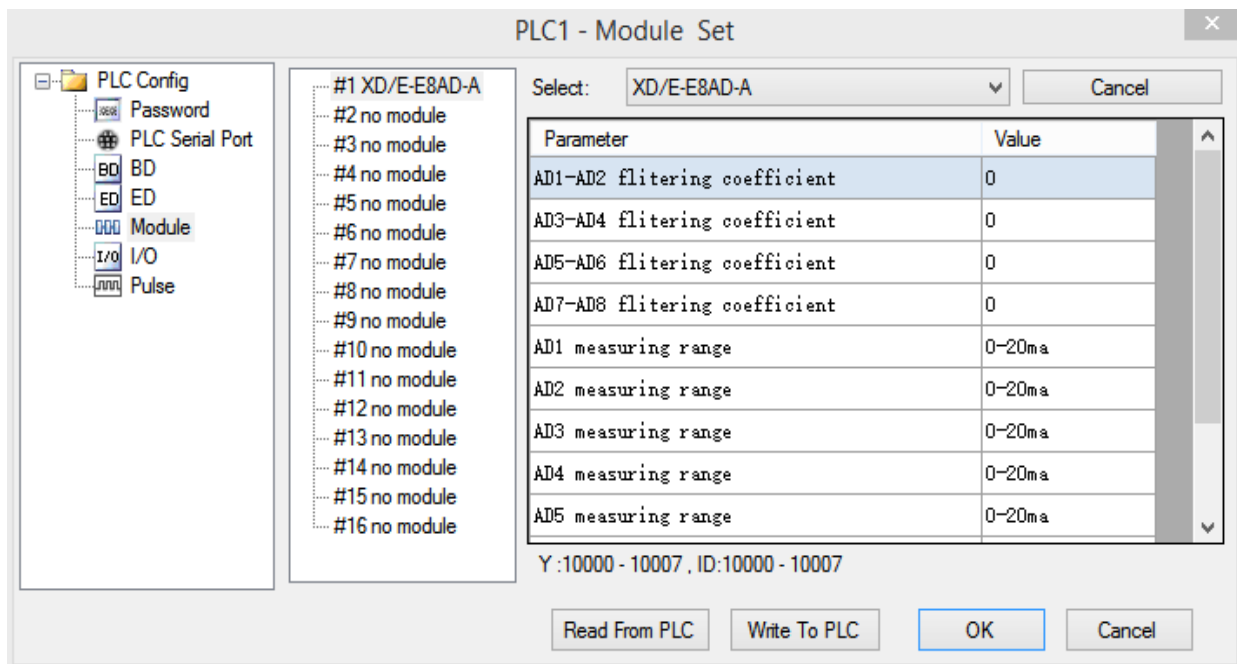

Flash registers:

The module input is current mode, the current range include 0~20mA, 4~20mA, -20~20mA. Set the modes through SFD registers of PLC. See the following table:

Module no.	SFD address	Module no.	SFD address
#1	SFD350~SFD359	#9	SFD430~SFD439
#2	SFD360~SFD369	#10	SFD440~SFD449
#3	SFD370~SFD379	#11	SFD450~SFD459
#4	SFD380~SFD389	#12	SFD460~SFD469
#5	SFD390~SFD399	#13	SFD470~SFD479
#6	SFD400~SFD409	#14	SFD480~SFD489
#7	SFD410~SFD419	#15	SFD490~SFD499
#8	SFD420~SFD429	#16	SFD500~SFD509

Note: each SFD register can set 4 channels mode. Each register has 16 bits, every 4 bits set one channel mode.

SFD bit definition:

BYTE0	Bit7	Bit6	Bit5	Bit4	Bit3	Bit2	Bit1	Bit0	Explanation
	AD channel 2, channel 1 filter time								AD filter time
BYTE1	AD channel 4, channel 3 filter time								
BYTE2	AD channel 6, channel 5 filter time								
BYTE3	AD channel 8, channel 7 filter time								
Byte4	Bit7	Bit6	Bit5	Bit4	Bit3	Bit2	Bit1	Bit0	To define the AD input range. Byte4 low 4 bits set channel 1 mode, high 4 bits set channel 2 mode. Byte5 low 4 bits set channel 3 mode, high 4 bits set channel 4 mode. Byte6 low 4 bits set channel 5 mode, high 4 bits set channel 6 mode. Byte7 low 4 bits set channel 7 mode, high 4 bits set channel 8 mode.
	AD2				AD1				
	-	-	00: 0~20mA 01: 4~20mA 10: -20~20mA		-	-	00: 0~20mA 01: 4~20mA 10: -20~20mA		
Byte5	Bit7	Bit6	Bit5	Bit4	Bit3	Bit2	Bit1	Bit0	
	AD4				AD3				
	-	-	00: 0~20mA 01: 4~20mA 10: -20~20mA		-	-	00: 0~20mA 01: 4~20mA 10: -20~20mA		
Byte6	Bit7	Bit6	Bit5	Bit4	Bit3	Bit2	Bit1	Bit0	
	AD6				AD5				
	-	-	00: 0~20mA 01: 4~20mA 10: -20~20mA		-	-	00: 0~20mA 01: 4~20mA 10: -20~20mA		
Byte7	Bit7	Bit6	Bit5	Bit4	Bit3	Bit2	Bit1	Bit0	
	AD8				AD7				
	-	-	00: 0~20mA 01: 4~20mA 10: -20~20mA		-	-	00: 0~20mA 01: 4~20mA 10: -20~20mA		
Byte8~ Byte19	-								

For example: set module no.1 channel 1 and channel 0 mode to 0~20mA. Set channel 3 and channel 2 mode to 4~20mA. Set channel 5 and channel 4 mode to -20~20mA. Set channel 7 and channel 6 mode to 4~20mA. The filter factor of channel 0 to channel 3 is 255. The filter factor of channel 4 to channel 7 is 100.

Then the SFD350=FFFFH SFD351=6464H SFD352=9988H SFD353=99AAH

14-5. Exterior connection

Notes:

- When connect external +24V power, please use the 24V power of PLC to avoid interference.
- To avoid interference, please use shield cable and single point ground for the shield layer.

Current input:

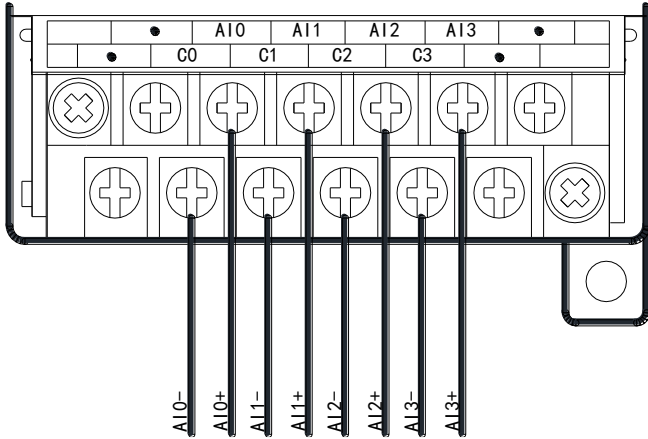

XD-E8AD-A current input wiring:

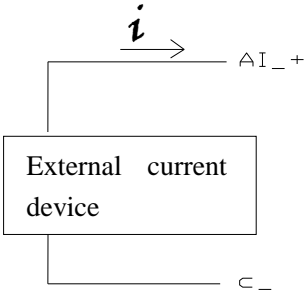

14-6. AD conversion diagram

The relationship between analog value and digital value is shown as the following diagram:

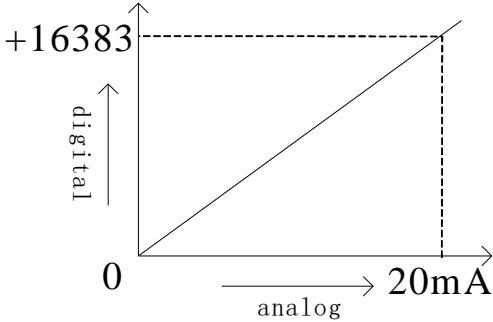
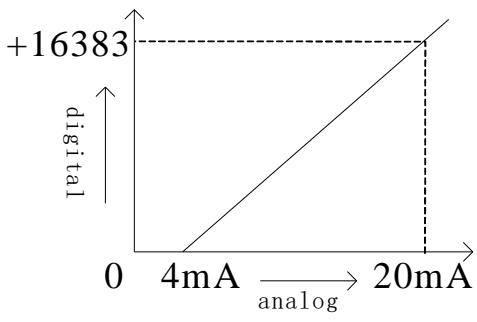
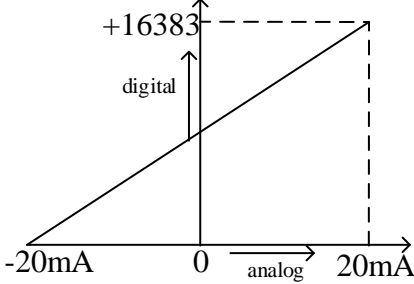
<p align="center">0~20mA current input</p>	<p align="center">4~20mA current input</p>
	
<p align="center">-20~20mA current input</p>	
	

14-7. Program application

Real-time read the data of the 8 channels (module no.1)

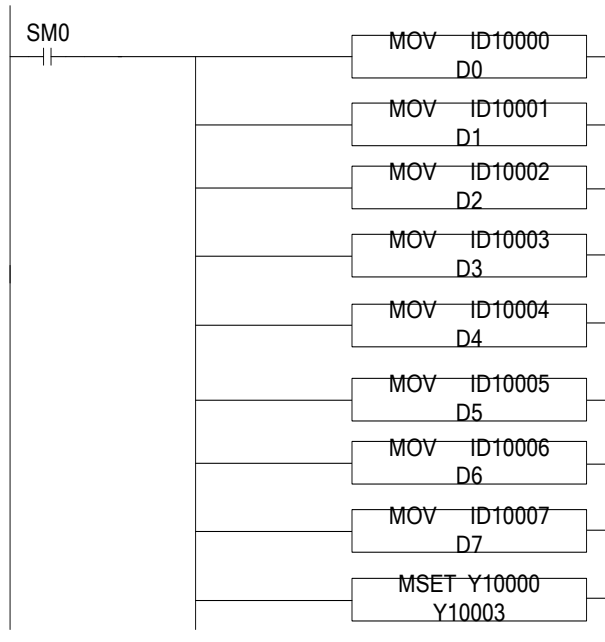

Explanation:

SM0 is always ON coil.

PLC is running. PLC keeps on writing channel 0 data to D0, channel 1 data to D1, channel 2 data to D2, channel 3 data to D3, channel 4 data to D4, channel 5 data to D5, channel 6 data to D6, channel 7 data to D7. Set ON all the channels enable bits.

15. Analog input module XD-E8AD-V

15-1. Specification

XD-E8AD-V transform the analog value (voltage input) to digital value and send to PLC registers.

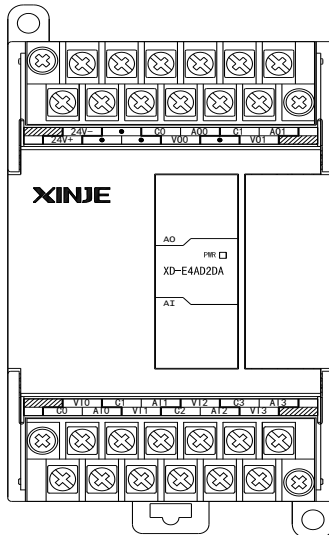

- 14 bits high precision analog input
- 8 channels analog voltage input
- The power supply of digital and analog part is isolated
- As special function module of XD3, up to 10 models can be connected.
- XDM can connect 16 modules

Items	Voltage input
Analog input range	0~5V, 0~10V, -10~10V, -5~5V
Max input range	DC ± 15V
Digital output range	14 bits binary data (0~16383)
PID control value	0~4095
Resolution	1/16383(14Bit)
Integrate Precision	1%
Conversion speed	2ms per channel
Analog power supply	DC24V ±10%, 150mA
Installation	Can be fixed with screw M3 or directly installed on orbit of DIN46277 (width: 35mm)
Dimension	63mm×108mm×79.9mm

15-2. Terminals

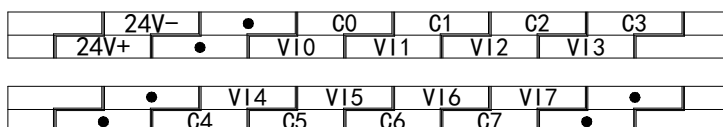

Channel	Terminal name	Signal name
CH0	VI0	voltage input
	C0	CH0 analog input common terminal
CH1	VI1	voltage input
	C1	CH1 analog input common terminal
CH2	VI2	voltage input
	C2	CH2 analog input common terminal
CH3	VI3	voltage input
	C3	CH3 analog input common terminal
CH4	VI4	voltage input
	C4	CH4 analog input common terminal
CH5	VI5	voltage input
	C5	CH5 analog input common terminal
CH6	VI6	voltage input
	C6	CH6 analog input common terminal
CH7	VI7	voltage input
	C7	CH7 analog input common terminal
-	24V+	+24V power supply
	24V-	Common terminal of power supply

15-3. I/O distribution

XD series analog expansion modules don't occupy I/O unit, the converted data is directly transferred to PLC register. Each channel address:

I/O address list

Register address of expansion module 1:

Channel	AD signal	Channel enable (set ON the enable bit to use this channel)
0CH	ID10000	Y10000
1CH	ID10001	Y10001
2CH	ID10002	Y10002
3CH	ID10003	Y10003
4CH	ID10004	Y10004

5CH	ID10005	Y10005
6CH	ID10006	Y10006
7CH	ID10007	Y10007

Register address of expansion module 2:

Channel	AD signal	Channel enable (set ON the enable bit to use this channel)
0CH	ID10100	Y10100
1CH	ID10101	Y10101
2CH	ID10102	Y10102
3CH	ID10103	Y10103
4CH	ID10104	Y10104
5CH	ID10105	Y10105
6CH	ID10106	Y10106
7CH	ID10107	Y10107

Register address of expansion module 3:

Channel	AD signal	Channel enable (set ON the enable bit to use this channel)
0CH	ID10200	Y10200
1CH	ID10201	Y10201
2CH	ID10202	Y10202
3CH	ID10203	Y10203
4CH	ID10204	Y10204
5CH	ID10205	Y10205
6CH	ID10206	Y10206
7CH	ID10207	Y10207

Register address of expansion module 4:

Channel	AD signal	Channel enable (set ON the enable bit to use this channel)
0CH	ID10300	Y10300
1CH	ID10301	Y10301
2CH	ID10302	Y10302

3CH	ID10303	Y10303
4CH	ID10304	Y10304
5CH	ID10305	Y10305
6CH	ID10306	Y10306
7CH	ID10307	Y10307

Register address of expansion module 5:

Channel	AD signal	Channel enable (set ON the enable bit to use this channel)
0CH	ID10400	Y10400
1CH	ID10401	Y10401
2CH	ID10402	Y10402
3CH	ID10403	Y10403
4CH	ID10404	Y10404
5CH	ID10405	Y10405
6CH	ID10406	Y10406
7CH	ID10407	Y10407

Register address of expansion module 6:

Channel	AD signal	Channel enable (set ON the enable bit to use this channel)
0CH	ID10500	Y10500
1CH	ID10501	Y10501
2CH	ID10502	Y10502
3CH	ID10503	Y10503
4CH	ID10504	Y10504
5CH	ID10505	Y10505
6CH	ID10506	Y10506
7CH	ID10507	Y10507

Register address of expansion module 7:

Channel	AD signal	Channel enable (set ON the enable bit to use this channel)
0CH	ID10600	Y10600
1CH	ID10601	Y10601

2CH	ID10602	Y10602
3CH	ID10603	Y10603
4CH	ID10604	Y10604
5CH	ID10605	Y10605
6CH	ID10606	Y10606
7CH	ID10607	Y10607

Register address of expansion module 8:

Channel	AD signal	Channel enable (set ON the enable bit to use this channel)
0CH	ID10700	Y10700
1CH	ID10701	Y10701
2CH	ID10702	Y10702
3CH	ID10703	Y10703
4CH	ID10704	Y10704
5CH	ID10705	Y10705
6CH	ID10706	Y10706
7CH	ID10707	Y10707

Register address of expansion module 9:

Channel	AD signal	Channel enable (set ON the enable bit to use this channel)
0CH	ID10800	Y11000
1CH	ID10801	Y11001
2CH	ID10802	Y11002
3CH	ID10803	Y11003
4CH	ID10804	Y11004
5CH	ID10805	Y11005
6CH	ID10806	Y11006
7CH	ID10807	Y11007

Register address of expansion module 10:

Channel	AD signal	Channel enable (set ON the enable bit to use this channel)
0CH	ID10900	Y11100

1CH	ID10901	Y11101
2CH	ID10902	Y11102
3CH	ID10903	Y11103
4CH	ID10904	Y11104
5CH	ID10905	Y11105
6CH	ID10906	Y11106
7CH	ID10907	Y11107

Register address of expansion module 11:

Channel	AD signal	Channel enable (set ON the enable bit to use this channel)
0CH	ID11000	Y11200
1CH	ID11001	Y11201
2CH	ID11002	Y11202
3CH	ID11003	Y11203
4CH	ID11004	Y11204
5CH	ID11005	Y11205
6CH	ID11006	Y11206
7CH	ID11007	Y11207

Register address of expansion module 12:

Channel	AD signal	Channel enable (set ON the enable bit to use this channel)
0CH	ID11100	Y11300
1CH	ID11101	Y11301
2CH	ID11102	Y11302
3CH	ID11103	Y11303
4CH	ID11104	Y11304
5CH	ID11105	Y11305
6CH	ID11106	Y11306
7CH	ID11107	Y11307

Register address of expansion module 13:

Channel	AD signal	Channel enable (set ON the enable bit to use this channel)
0CH	ID11200	Y11400
1CH	ID11201	Y11401
2CH	ID11202	Y11402
3CH	ID11203	Y11403
4CH	ID11204	Y11404
5CH	ID11205	Y11405
6CH	ID11206	Y11406
7CH	ID11207	Y11407

Register address of expansion module 14:

Channel	AD signal	Channel enable (set ON the enable bit to use this channel)
0CH	ID11300	Y11500
1CH	ID11301	Y11501
2CH	ID11302	Y11502
3CH	ID11303	Y11503
4CH	ID11304	Y11504
5CH	ID11305	Y11505
6CH	ID11306	Y11506
7CH	ID11307	Y11507

Register address of expansion module 15:

Channel	AD signal	Channel enable (set ON the enable bit to use this channel)
0CH	ID11400	Y11600
1CH	ID11401	Y11601
2CH	ID11402	Y11602
3CH	ID11403	Y11603
4CH	ID11404	Y11604
5CH	ID11405	Y11605

6CH	ID11406	Y11606
7CH	ID11407	Y11607

Register address of expansion module 16:

Channel	AD signal	Channel enable (set ON the enable bit to use this channel)
0CH	ID11500	Y11700
1CH	ID11501	Y11701
2CH	ID11502	Y11702
3CH	ID11503	Y11703
4CH	ID11504	Y11704
5CH	ID11505	Y11705
6CH	ID11506	Y11706
7CH	ID11507	Y11707

Note:

3. Forbid the unused channel to improve the I/O scanning speed.
4. If set off the enable bit of the channel, this channel will not accept the data. (the data display is 0).

15-4. Working mode

There are two ways to set the working mode:

1. XDPpro software
2. Flash registers of PLC

XDPpro software:

Open the XDPpro software, click configure/expansion module settings:

Set the model and channel parameters in the following window. Then click write to PLC.

Please restart the PLC after setting.

Note: first-order low-pass filter will weighted present sampling value with last time filter output to get the final filter value. The filter factor range is 0 to 255, the default value is 0 which means no filter.

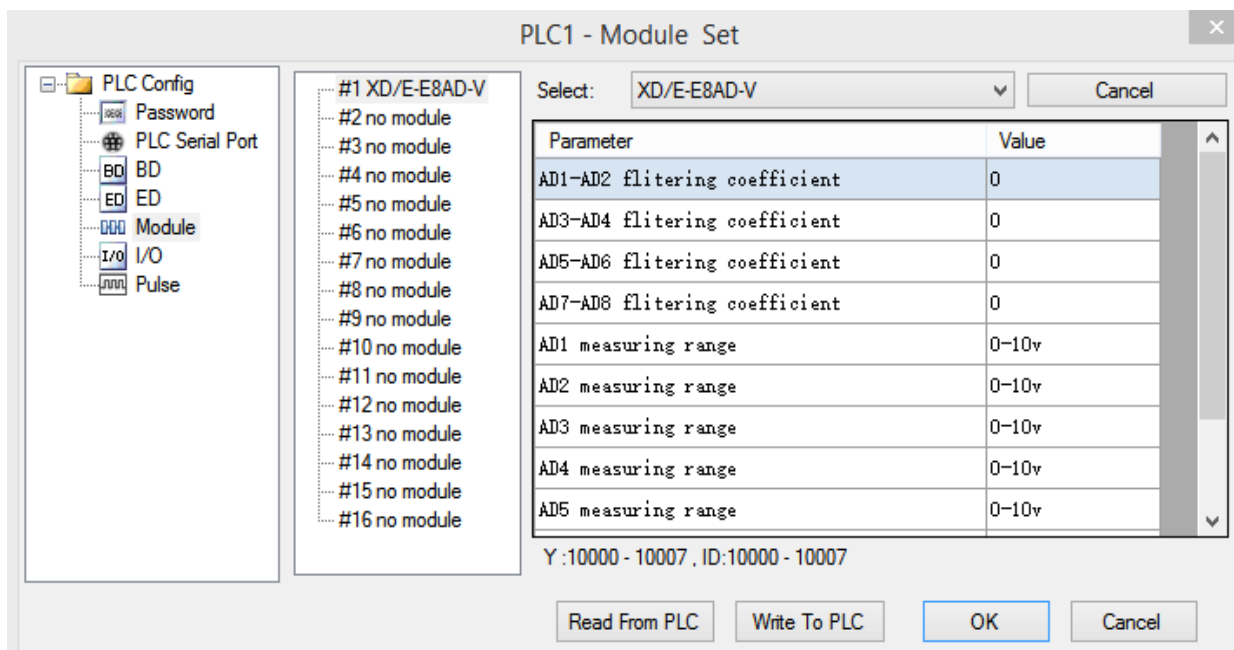

Flash registers:

The module is voltage input mode, the voltage range include 0~10V, 0~5V, -10~10V, -5~5V. Set the modes through SFD registers of PLC. See the following table:

Module no.	SFD address	Module no.	SFD address
#1	SFD350~SFD359	#9	SFD430~SFD439
#2	SFD360~SFD369	#10	SFD440~SFD449
#3	SFD370~SFD379	#11	SFD450~SFD459
#4	SFD380~SFD389	#12	SFD460~SFD469
#5	SFD390~SFD399	#13	SFD470~SFD479
#6	SFD400~SFD409	#14	SFD480~SFD489
#7	SFD410~SFD419	#15	SFD490~SFD499
#8	SFD420~SFD429	#16	SFD500~SFD509

Note: each SFD register can set 4 channels mode. Each register has 16 bits, every 4 bits set one channel mode.

SFD bit definition:

BYTE0	Bit7	Bit6	Bit5	Bit4	Bit3	Bit2	Bit1	Bit0	Explanation
	AD channel 2, channel 1 filter time								AD filter time
BYTE1	AD channel 4, channel 3 filter time								
BYTE2	AD channel 6, channel 5 filter time								
BYTE3	AD channel 8, channel 7 filter time								
Byte4	Bit7	Bit6	Bit5	Bit4	Bit3	Bit2	Bit1	Bit0	To define the AD input range. Byte4 low 4 bits set channel 1 mode, high 4 bits set channel 2 mode. Byte5 low 4 bits set channel 3 mode, high 4 bits set channel 4 mode. Byte6 low 4 bits set channel 5 mode, high 4 bits set channel 6 mode. Byte7 low 4 bits set channel 7 mode, high 4 bits set channel 8 mode.
	AD2				AD1				
	-	-	00: 0~10V 01: 0~5V 10: -10V~10V 11: -5V~5V		-	-	00: 0~10V 01: 0~5V 10: -10V~10V 11: -5V~5V		
Byte5	Bit7	Bit6	Bit5	Bit4	Bit3	Bit2	Bit1	Bit0	
	AD4				AD3				
	-	-	00: 0~10V 01: 0~5V 10: -10V~10V 11: -5V~5V		-	-	00: 0~10V 01: 0~5V 10: -10V~10V 11: -5V~5V		
Byte6	Bit7	Bit6	Bit5	Bit4	Bit3	Bit2	Bit1	Bit0	
	AD6				AD5				
	-	-	00: 0~10V 01: 0~5V 10: -10V~10V 11: -5V~5V		-	-	00: 0~10V 01: 0~5V 10: -10V~10V 11: -5V~5V		
Byte7	Bit7	Bit6	Bit5	Bit4	Bit3	Bit2	Bit1	Bit0	
	AD8				AD7				
	-	-	00: 0~10V 01: 0~5V 10: -10V~10V 11: -5V~5V		-	-	00: 0~10V 01: 0~5V 10: -10V~10V 11: -5V~5V		
Byte8~ Byte19	-								

For example: set module no.1 channel 1 and channel 0 mode to 0~10V. Set channel 3 and channel 2 mode to 0~5V. Set channel 5 and channel 4 mode to -5~5V. Set channel 7 and channel 6 mode to -10~10V. The filter factor of channel 0 to channel 3 is 255. The filter factor of channel 4 to channel 7 is 100.

Then the SFD350=FFFFH SFD351=6464H SFD352=1100H SFD353=2233H

15-5. Exterior connection

Notes:

- When connect external +24V power, please use the 24V power of PLC to avoid interference.
- To avoid interference, please use shield cable and single point ground for the shield layer.

Voltage input:

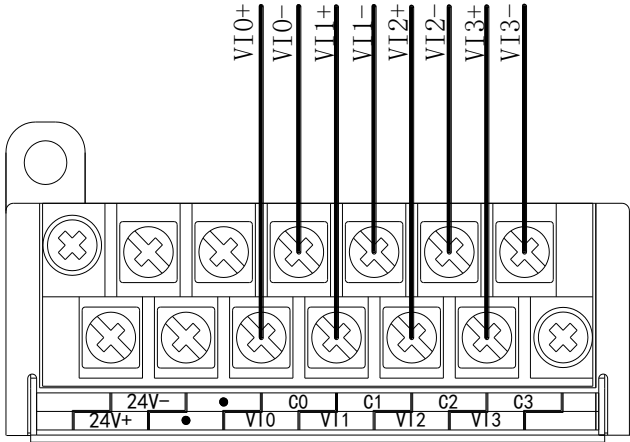

15-6. AD conversion diagram

The relationship between analog value and digital value is shown as the following diagram:

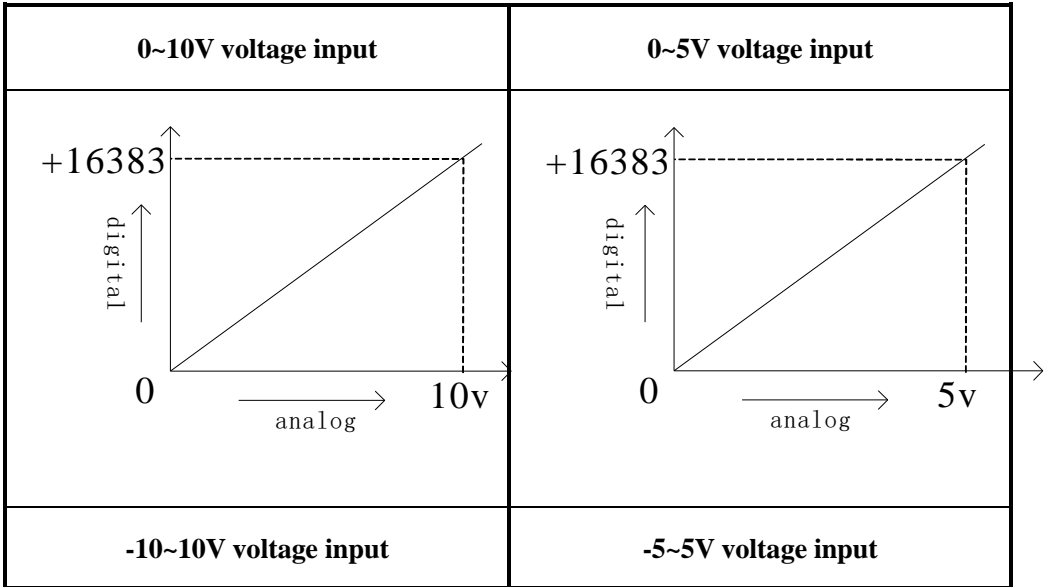

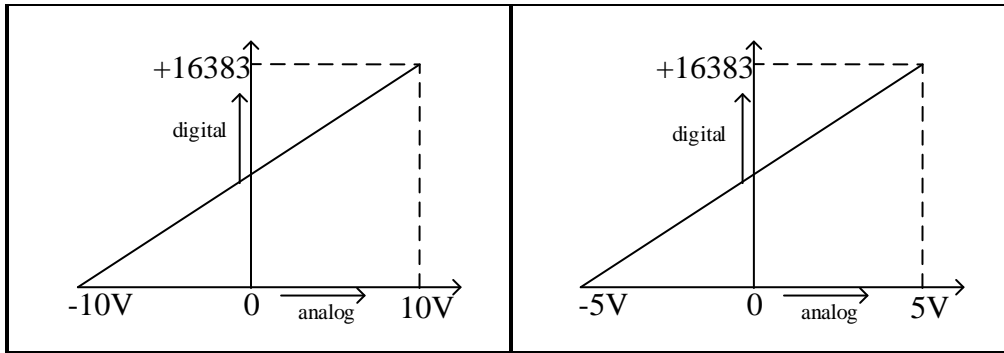

15-7. Program application

Real-time read the data of the 8 channels (module no.1)

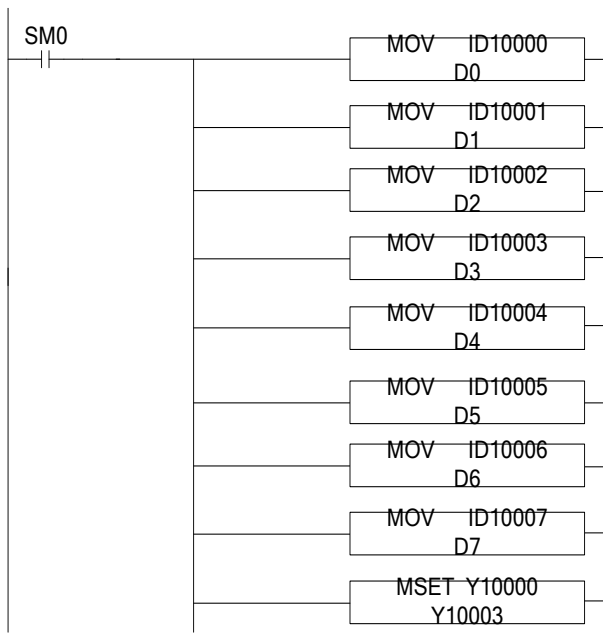

Explanation:

SM0 is always ON coil.

PLC is running. PLC keeps on writing channel 0 data to D0, channel 1 data to D1, channel 2 data to D2, channel 3 data to D3, channel 4 data to D4, channel 5 data to D5, channel 6 data to D6, channel 7 data to D7.

Set ON all the channels enable bits.

16. X-NET relay module JR-EH

16-1. Suitable condition

JR-EH is X-NET relay module which fit for RS485 communication. The signal will be affected and bit error rate will rise when system baud rate is high, and there are many nodes or the distance is long. This module is recommended to improve the communication quality.

16-2. Features

Item	Parameter
Power supply	DC24V \pm 10%
Temperature/humidity	-15~65°C, 5%~95% no condensation
Standard	Accords to IEC-61000-4-2, IEC61000-4-4, IEC61000-4-5
Max load numbers	32
Baud rate	9600bps~3Mbps

16-3. Appearance

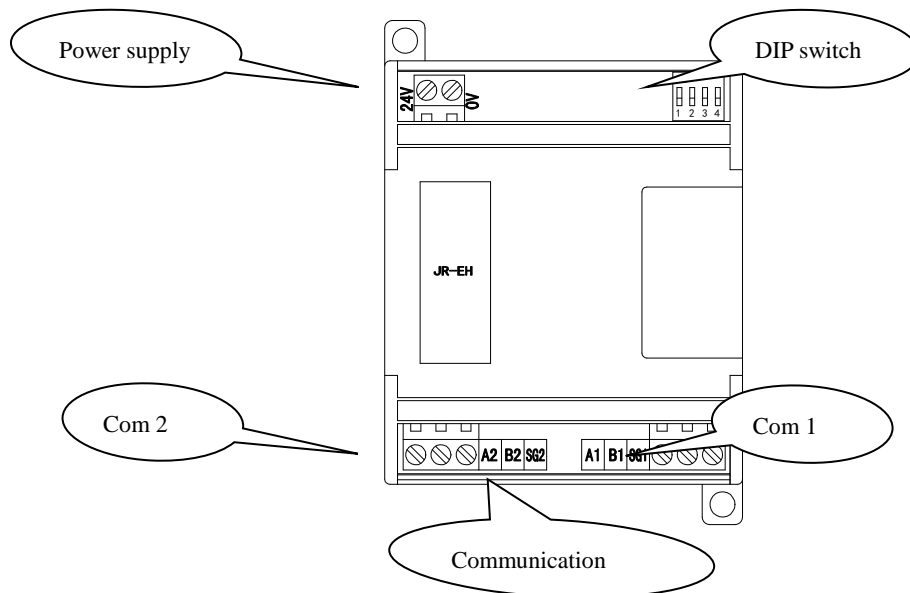

Com1 and com2 has no master and slave, they can wiring as needs. Terminal A, B is for RS485, SG is ground terminal.

16-4. Baud rate

DIP switch	Baud rate	DIP switch	Baud rate
0000	Self-adaption	1000	256K
0001	9.6K	1001	288K
0010	19.2K	1010	384K
0011	28.8K	1011	512K
0100	38.4K	1100	576K
0101	57.6K	1101	768K
0110	115.2K	1110	1M
0111	192K	1111	3M

The two devices communicate with the same baud rate when the module is in self-adaption mode, the relay will lock the baud rate in 1 second and transfer the data. If the device communication has error, the relay will fail to lock the baud rate. We suggest user to choose fixed baud rate, user can use self-adaption mode if the baud rate is not listed in the above table.

16-5. LED

When the module is in self-adaption mode, LED always ON means the baud rate has been locked, LED OFF means it has not been locked.

When the module is in fixed baud rate state, LED flickering means the communication is normal, LED always ON means the communication has error.

16-6. Wiring diagram

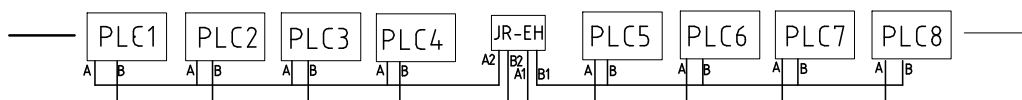

Please use the shielded twisted pair accords to EIA-485, resistor is 120ohm.

The relationship between baud rate and communication distance

Baud rate	Max distance
9.6-187.5Kbit/s	1000m
500Kbit/s	400m
1.5Mbit/s	200m
3Mbit/s	100m

16-7. Module naming rule

J	R	-	E	H
^	^		^	^
Module type	Repeater		RS485	High speed

16-8. Dimension

Unit:mm

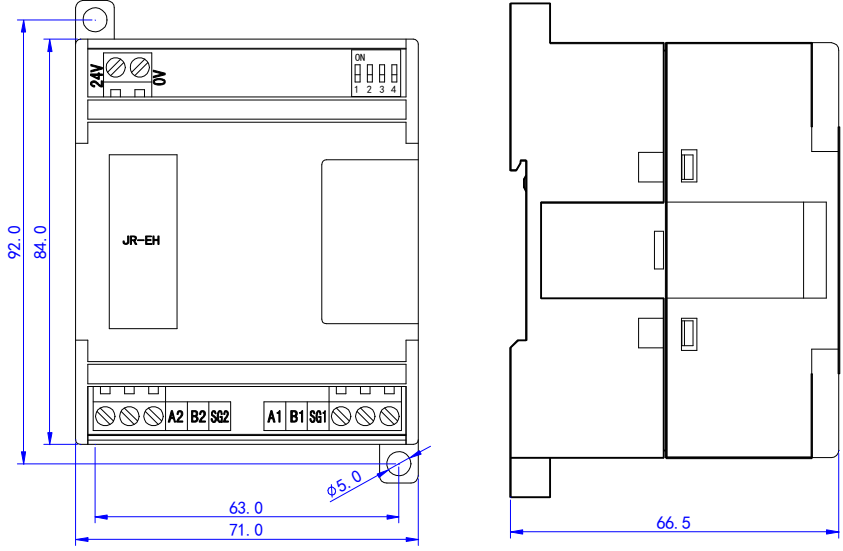

17. 4 channels pressure module XD-E4WT-C

17-1. Features

XD-E4WT-C is the expansion module of XD series PLC. It can test the voltage in the range of 0~10mV or the voltage signal from pressure sensor. Then it can transform the voltage to digital value through A/D transformation and do calculation.

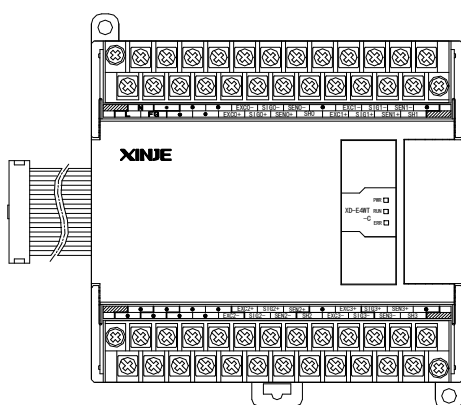

- 4 channels pressure sensor voltage signal input
- Test voltage signal in the range of 0~10mV
- 24-bit A/D transformation
- XD3 series PLC can connect 10 XD-E4WT-C modules
- XDM/XD5/XDC/XD5E series PLC can connect 16 XD-E4WT-C modules

Input range	DC 0~10mV (sensor 2mv/v)
AD real resolution	1/1048575 (20bit)
Max display resolution	1/300000
Non-linear	0.01%F.S
Transformation speed	150/300/450times/second (optional)
Power supply	AC220V ± 10% 50/60Hz
Sensor power supply	5VDC/120mA, can parallel 4 pieces of 350Ω pressure sensor
Dimension	108.6mm×108.0mm×89.9mm
Installation	Mount on DIN46277 rail (width 35mm) or fix with screw M3
Software version	V3.5.1 and higher version
Working environment	No corrosive gas
Ambient temperature	-10°C~50°C
Humidity	5~95%RH (no condensation)

17-2. Terminals

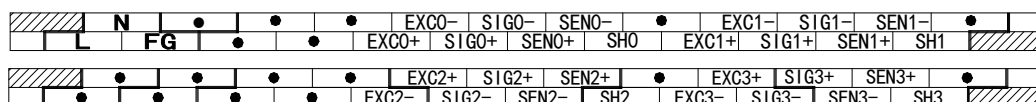

Channel	Terminal	Signal	Meaning
CH1	EXC1+	Excitation +	Connect to sensor power supply input
	EXC1-	Excitation -	
	SIG1+	Signal +	Connect to sensor signal output

	SIG1-	Signal -	Connect to sensor feedback voltage output
	SEN1+	Feedback +	
	SEN1-	Feedback -	
	SH1	Shield	
CH2	EXC1+	Excitation +	Connect to sensor power supply input
	EXC1-	Excitation -	
	SIG2+	Signal +	Connect to sensor signal output
	SIG2-	Signal -	
	SEN2+	Feedback +	Connect to sensor feedback voltage output
	SEN2-	Feedback -	
	SH2	Shield	Connect to sensor ground terminal
CH3	EXC2+	Excitation +	Connect to sensor power supply input
	EXC2-	Excitation -	
	SIG3+	Signal +	Connect to sensor signal output
	SIG3-	Signal -	
	SEN3+	Feedback +	Connect to sensor feedback voltage output
	SEN3-	Feedback -	
	SH3	Shield	Connect to sensor ground terminal
CH4	EXC2+	Excitation +	Connect to sensor power supply input
	EXC2-	Excitation -	
	SIG4+	Signal +	Connect to sensor signal output
	SIG4-	Signal -	
	SEN4+	Feedback +	Connect to sensor feedback voltage output
	SEN4-	Feedback -	
	SH4	Shield	Connect to sensor ground terminal
-	L, N	Module power supply	Give power to module, AC220V \pm 10% 50/60Hz
	FG	Power supply ground	Connect to ground

17-3. External connection

Please use shield cable and single-point connect to the ground for shield layer.

Power supply wiring

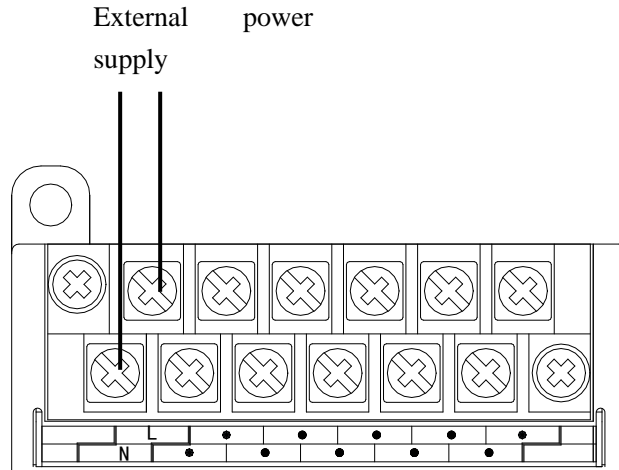

Connect to sensor

6 wires mode:

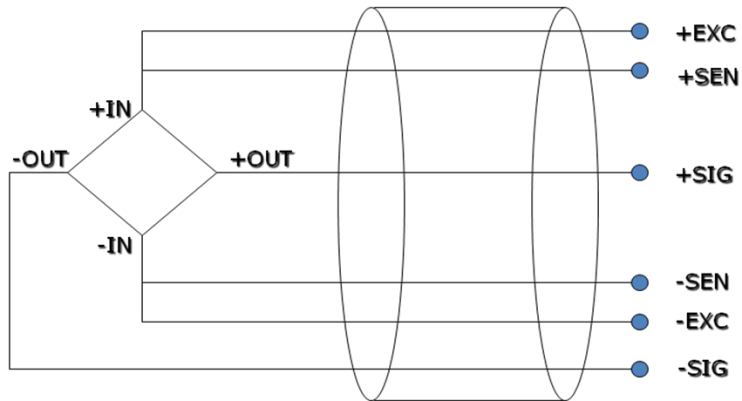

4 wires mode:

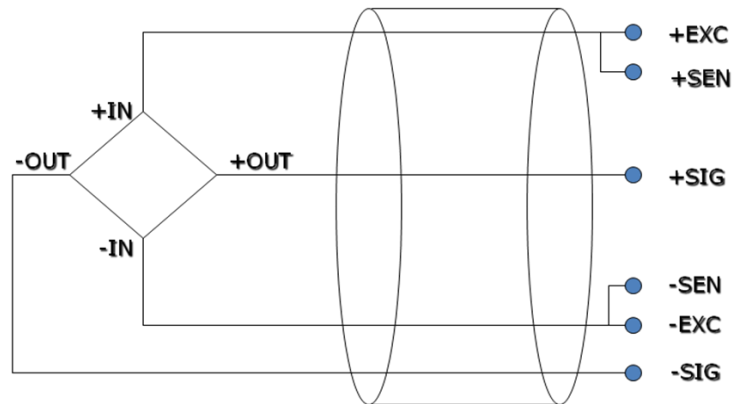

Note: short connect EXC1- and SEN1-, short connect EXC1+ and SEN1+ for 4 wires mode sensor.

17-4. Weighing system

A typical weighing system:

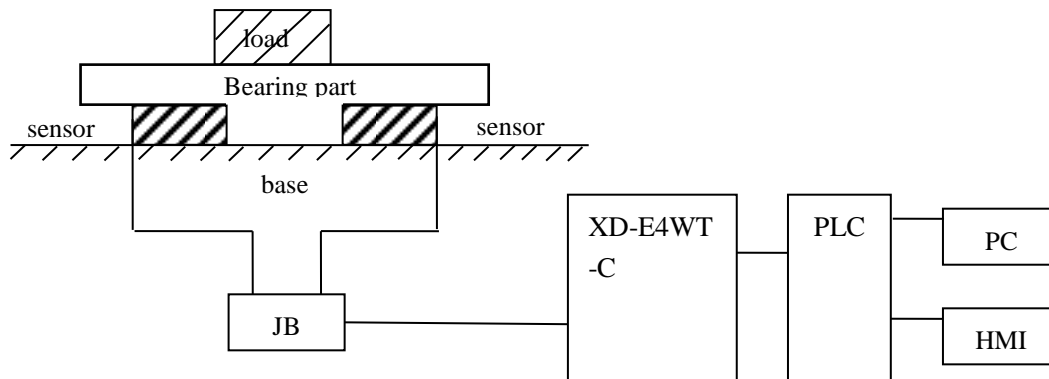

Loading bearing part: to support the load. Such as flat, hopper, container, air transport car...

Pressure sensor: transform the weight to voltage signal.

Assembly part: make sure the pressure sensor can work correctly, assembly part and direct part can avoid overload. Overload will cause measurement error and sensor damage.

Connection box (JB): to collect several sensor signals.

XD-E4WT-C: can be used as an electronic assessment device, it gets the pressure sensor signal and makes further assessment.

17-5. Module functions

XD-E4WT-C has the follow functions:

- Adjust the pressure sensor
- Collect the pressure sensor signal
- Calculate the weight value
- 0~10mV voltage signal test

17-5-1. Pressure sensor

The pressure sensor is based on resistance strain effect, see the following diagram:

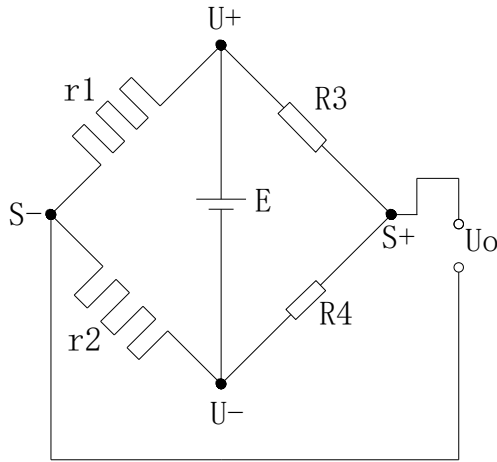

R1 and R2 is strain resistor which make bridge circuit with R3 and R4. With the change of R1 and R2, the bridge circuit will lose the balance, unbalance voltage U_o will be produced as the output of sensor.

U_+ and U_- are positive and negative point of the sensor power supply. Please select the 5V power of the module or from outside.

S_+ and S_- are positive and negative point of the sensor output. Connect the output to the module to test the weight.

17-6. I/O address

The I/O address of module 1:

Soft component		Address	Explanation	Note
Output coil	CH1	Y10000	Filter level	
		Y10001	Reset	
		Y10002	Zero point calibration	
		Y10003	Gain calibration	
	CH2	Y10004	Filter level	
		Y10005	Reset	
		Y10006	Zero point calibration	
		Y10007	Gain calibration	
	CH3	Y10010	Filter level	
		Y10011	Reset	
		Y10012	Zero point calibration	
		Y10013	Gain calibration	
	CH4	Y10014	Filter level	
		Y10015	Reset	
		Y10016	Zero point calibration	
		Y10017	Gain calibration	
	ALL	Y10020	Back to out of factory value	
	CH1	X10000	Stable flag	

Input coil		X10001	Overflow flag		
		X10002	Calibration success flag		
		X10003	Calibration failure flag		
	CH2	X10004	Stable flag		
		X10005	Overflow flag		
		X10006	Calibration success flag		
		X10007	Calibration failure flag		
	CH3	X10010	Stable flag		
		X10011	Overflow flag		
		X10012	Calibration success flag		
		X10013	Calibration failure flag		
	CH4	X10014	Stable flag		
		X10015	Overflow flag		
		X10016	Calibration success flag		
		X10017	Calibration failure flag		
	Input register	CH1	ID10000	Present weight	Double words
			ID10002	Present digital value/present input voltage	Double words
CH2		ID10004	Present weight	Double words	
		ID10006	Present digital value/present input voltage	Double words	
CH3		ID10008	Present weight	Double words	
		ID10010	Present digital value/present input voltage	Double words	
CH4		ID10012	Present weight	Double words	
		ID10014	Present digital value/present input voltage	Double words	

The I/O address of module 2:

Soft component		Address	Explanation	Note
Output coil	CH1	Y10100	Filter level	
		Y10101	Reset	
		Y10102	Zero point calibration	
		Y10103	Gain calibration	
	CH2	Y10104	Filter level	
		Y10105	Reset	
		Y10106	Zero point calibration	
		Y10107	Gain calibration	
	CH3	Y10110	Filter level	
		Y10111	Reset	
		Y10112	Zero point calibration	
		Y10113	Gain calibration	
	CH4	Y10114	Filter level	
		Y10115	Reset	
		Y10116	Zero point calibration	

		Y10117	Gain calibration	
	ALL	Y10120	Back to out of factory value	
Input coil	CH1	X10100	Stable flag	
		X10101	Overflow flag	
		X10102	Calibration success flag	
		X10103	Calibration failure flag	
	CH2	X10104	Stable flag	
		X10105	Overflow flag	
		X10106	Calibration success flag	
		X10107	Calibration failure flag	
	CH3	X10110	Stable flag	
		X10111	Overflow flag	
		X10112	Calibration success flag	
		X10113	Calibration failure flag	
	CH4	X10114	Stable flag	
		X10115	Overflow flag	
		X10116	Calibration success flag	
		X10117	Calibration failure flag	
Input register	CH1	ID10100	Present weight	Double words
		ID10102	Present digital value/present input voltage	Double words
	CH2	ID10104	Present weight	Double words
		ID10106	Present digital value/present input voltage	Double words
	CH3	ID10108	Present weight	Double words
		ID10110	Present digital value/present input voltage	Double words
	CH4	ID10112	Present weight	Double words
		ID10114	Present digital value/present input voltage	Double words

.....

The I/O address of module 16:

Soft component		Address	Explanation	Note
Output coil	CH1	Y11500	Filter level	
		Y11501	Reset	
		Y11502	Zero point calibration	
		Y11503	Gain calibration	
	CH2	Y11504	Filter level	
		Y11505	Reset	
		Y11506	Zero point calibration	
		Y11507	Gain calibration	
	CH3	Y11510	Filter level	
		Y11511	Reset	
		Y11512	Zero point calibration	
		Y11513	Gain calibration	

	CH4	Y11514	Filter level	
		Y11515	Reset	
		Y11516	Zero point calibration	
		Y11517	Gain calibration	
	ALL	Y10020	Back to out of factory value	
Input coil	CH1	X11500	Stable flag	
		X11501	Overflow flag	
		X11502	Calibration success flag	
		X11503	Calibration failure flag	
	CH2	X11504	Stable flag	
		X11505	Overflow flag	
		X11506	Calibration success flag	
		X11507	Calibration failure flag	
	CH3	X11510	Stable flag	
		X11511	Overflow flag	
		X11512	Calibration success flag	
		X11513	Calibration failure flag	
	CH4	X11514	Stable flag	
		X11515	Overflow flag	
		X11516	Calibration success flag	
		X11517	Calibration failure flag	
Input register	CH1	ID11500	Present weight	Double words
		ID11502	Present digital value/present input voltage	Double words
	CH2	ID11504	Present weight	Double words
		ID11506	Present digital value/present input voltage	Double words
	CH3	ID11508	Present weight	Double words
		ID11510	Present digital value/present input voltage	Double words
	CH4	ID11512	Present weight	Double words
		ID11514	Present digital value/present input voltage	Double words

Address explanation:

filter level	ON: filter level A, OFF: filter level B
Reset	The reset is valid in the reset range, not save zero point
zero point calibration	To calibrate the system zero point
gain calibration	To calibrate system linear
Stable flag	The signal output is effective when meeting the stable range and time
Overflow flag	When the signal voltage larger than 10mv, this signal output is effective
Calibration success flag	This signal output is effective when zero point calibration and gain calibration succeeded
Calibration failure flag	This signal output is effective when zero point calibration and gain calibration failed (the detailed reasons please check module applicatoin error info)
Present digital value/present input	Switch through upper device, when it is switched to present input voltage, the unit is mv, the decimal place is 4 bits

voltage

17-7. Working mode

There are two method to set the working mode:

1. set through the control panel
2. set through Flash register

Open the XD PLC software, click the menu configure/expansion module setting.

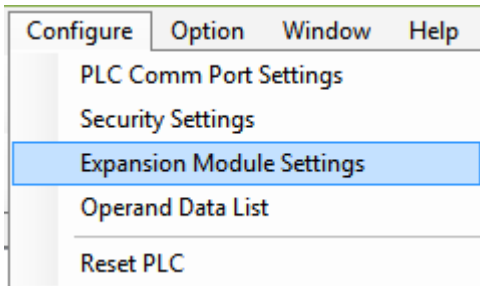

Choose the correct model and configuration information:

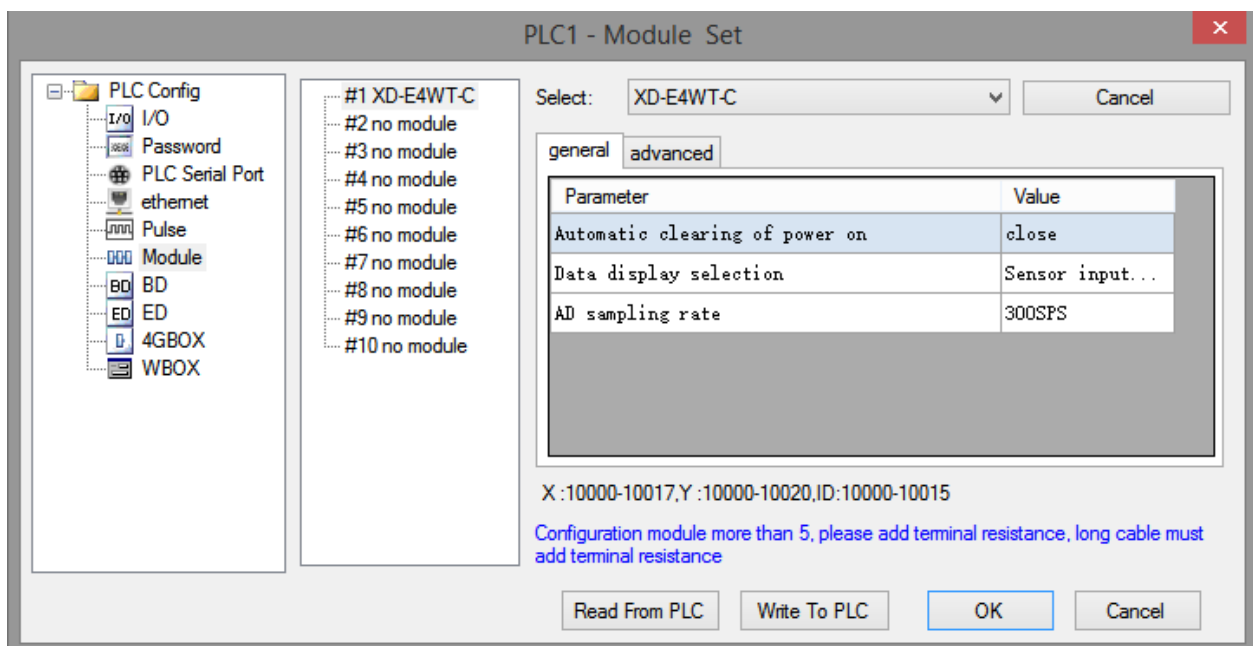

Flash register setting:

The expansion module can set the gear and user-defined fast sampling frequency through PLC flash register SFD.

Module no.	SFD address	Module no.	SFD address
#1	SFD350~SFD359	#9	SFD430~SFD439

#2	SFD360~SFD369	#10	SFD440~SFD449
#3	SFD370~SFD379	#11	SFD450~SFD459
#4	SFD380~SFD389	#12	SFD460~SFD469
#5	SFD390~SFD399	#13	SFD470~SFD479
#6	SFD400~SFD409	#14	SFD480~SFD489
#7	SFD410~SFD419	#15	SFD490~SFD499
#8	SFD420~SFD429	#16	SFD500~SFD509

SFD350~SFD359 register explanation:

SFD		Bit7	Bit6	Bit5	Bit4	Bit3	Bit2	Bit1	Bit0	NOTE	
SFD350	Byte0	AD sampling speed Range 0~2 Initial value: 1 0: 150 time/second 1: 300 time/second 2: 450 time/second						Sampling data mode Initial value: 0 0: sensor input voltage (mv) 1: AD sampling digital value	Automatical reset when power on Initial value: 0 0: OFF 1: ON		All the channels
	Byte1										
SFD351	Byte2										
	Byte3										
SFD352	Byte4										
	Byte5										
SFD353	Byte6										
	Byte7										
SFD354	Byte8										
	Byte9										
SFD355	Byte10										
	Byte11										
SFD356	Byte12										
	Byte13										
SFD357	Byte14										

	Byte15		
SFD358	Byte16		
	Byte17		
SFD359	Byte18		
	Byte19		

17-8. Module setting

Module parameter list:

Address	Contents	Explanation		Features
K0	Zero point tracking range	Range: 0~9 Initial value: 5	All the channels	Word R/W
K1	Zero point tracking time	Range: 500~5000 (ms) Initial value: 2000		Word R/W
K2	Reset range	Range: 1~99 (%) Initial value: 50		Word R/W
K3	Stable range	Range: 1~99 Initial value: 3		Word R/W
K4	Stable time	Range: 10~5000 (ms) Initial value: 100		Word R/W
K5	Filter level A	Range: 0~9 Initial value: 3		Word R/W
K6	Filter level B	Range: 0~9 Initial value: 5		Word R/W
K7~K9	Reserved			
K10	Zero point calibration voltage return value	Return the present sensor input voltage after calibrating the zero point	CH1	Dword R
K12	Gain calibration digital value/gain calibration voltage return value	As weight input value for gain calibration. As return relative voltage for non-calibration		Dword R/W
K14	CH1 min scale division	Range: 1,2,5,10,20,50		Word R/W
K15	CH1 max range	Range: <1000000		Dword R/W
K17	Reserved			
K20	Zero calibration voltage return value	Return the present sensor input voltage after calibrating the zero point	CH2	Dword R
K22	Gain calibration value/gain calibration voltage return value	As weight input value for gain calibration. As return relative voltage for non-calibration		Dword R/W
K24	CH2 min scale division	Range: 1,2,5,10,20,50		Word R/W

K25	CH2 max range	Range: <1000000		Dword R/W
K27	Reserved			
K30	Zero calibration voltage return value	Return the present sensor input voltage after calibrating the zero point		Dword R
K32	Gain calibration value/gain calibration voltage return value	As weight input value for gain calibration. As return relative voltage for non-calibration	CH3	Dword R/W
K34	CH3 min scale division	Range: 1,2,5,10,20,50		Word R/W
K35	CH3 max range	Range: <1000000		Dword R/W
K37	Reserved			
K40	Zero calibration voltage return value	Return the present sensor input voltage after calibrating the zero point	CH4	Dword R
K42	Gain calibration value/gain calibration voltage return value	As weight input value for gain calibration. As return relative voltage for non-calibration		Dword R/W
K44	CH4 min scale division	Range: 1,2,5,10,20,50		Word R/W
K45	CH4 max range	Range: <1000000		Dword R/W
K47	Reserved			

Take module no.1 as an example:

Weight unit setting:

Write in weight through instruction TO. For example, the object weight is 1kg, write in 1 means the unit is kg, write in 1000 means the unit is g, write in 10000 means the unit is 0.1g. resolution=1kg/write in digital value.

Calibration:

Please calibrate the pressure sensor for the first time using.

Take module channel 1 as an example:

1. confirm whether the module and sensor work properly.

Judgment method:

First, monitor whether the overflow flag X10001 is OFF state. If it is ON, the sensor is not connected or the sensor is damaged.

Second, using the software to monitor whether ID10002 value fluctuates following sensor (fluctuation range is related to sensor range), and pressure value increased when increasing the load, if there are value but increase the load stress value decreases, that means (1) sensor installed opposite, please adjust the sensor position or exchange +/- of sensor output signal; (2) The incoming voltage signal has been overflow, reducing the load appropriately.

2. Make the sensor no load, after the stable flag X10000 is ON, set ON zero point calibration Y10002. X10002 ON means the zero point calibration is successful. If after few seconds, X10003 is ON, that means zero point calibration is failed.

3. Put the load whose weight is known on the scale, write the weight through TO instruction, after stable flag X10000 is ON, set ON gain calibration Y10003, X10002 ON means calibration is successful, shut off Y10003. If after few seconds, X10003 is ON, that means zero point calibration is failed.

4. Hereto, the calibration finished. The module will automatic adjust the result according to the idle load value and calibration value when weighing, and finally get the correct weight.

17-9. Module error info

Serious application error (related to main unit register address SD503 high 8 bits)

Error code			Meaning
Binary	Hex	Decimal	
0000 0001	0x01	1	Not connect 24V
0000 0010	0x02	2	Not finish the setting in 5s
0000 0011	0x03	3	Module model is different
0000 0011	0x04	4	Communicate with PLC error

The error code using method: write in module no. in SD500, if it needs to check module no.1 error code, please write in 10000.

17-10. Instruction FROM and TO

Write instruction TO

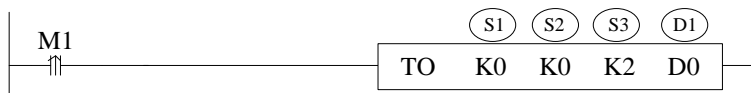

Function: write the PLC register data to module specified address, the unit is word.

Operand:

S1: target module number. Operand: K, TD, CD, D, HD, FD.

S2: module first address. Operand: K, TD, CD, D, HD, FD.

S3: write in register quantity. Operand: K, TD, CD, D, HD, FD.

D1: write in data register first address in PLC. Operand: TD, CD, D, HD, FD.

Example: write the weight value to module no.1 channel 1

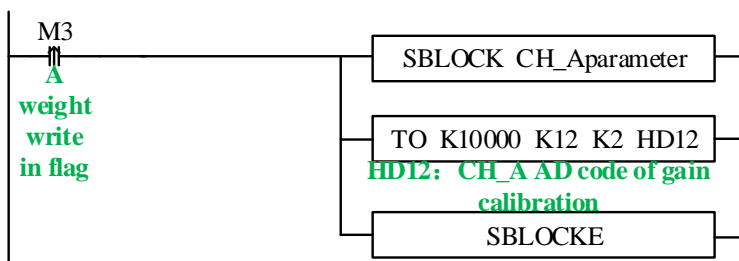

Read instruction FROM



Function: read the module data to PLC register, the unit is word.

Operand:

S1: target module number. Operand: K, TD, CD, D, HD, FD.

S2: module first address. Operand: K, TD, CD, D, HD, FD.

S3: read register quantity. Operand: K, TD, CD, D, HD, FD.

D1: PLC register first address. Operand: TD, CD, D, HD, FD.

For example: read all the parameters of module no.1

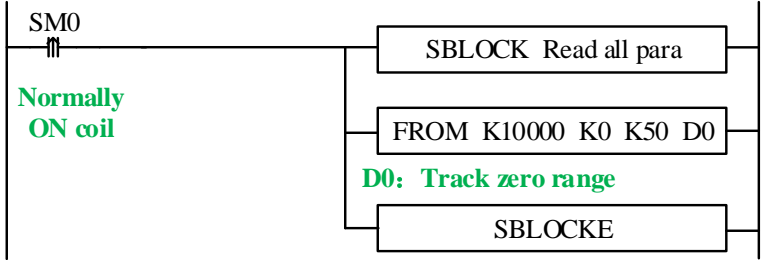

Note: FROM and TO instruction only can be added in sequence block, one program can support 100 sequence blocks. But only 8 sequence blocks can execute at the same time.

17-11. AD transformation diagram

The relationship between input voltage and transformed digital value is shown as below:

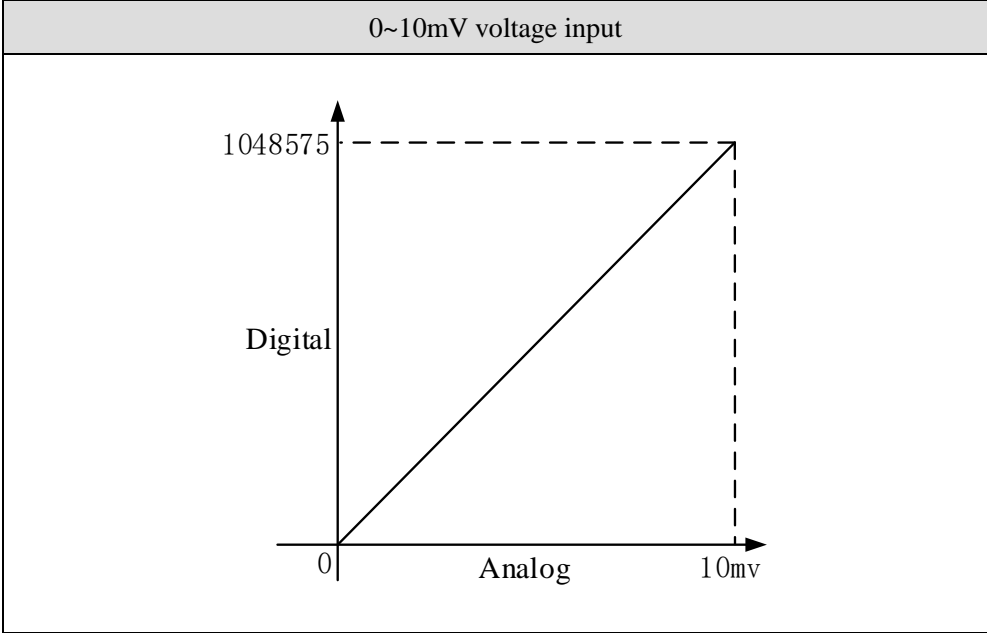

17-12. Application program

Take module 1 as an example:

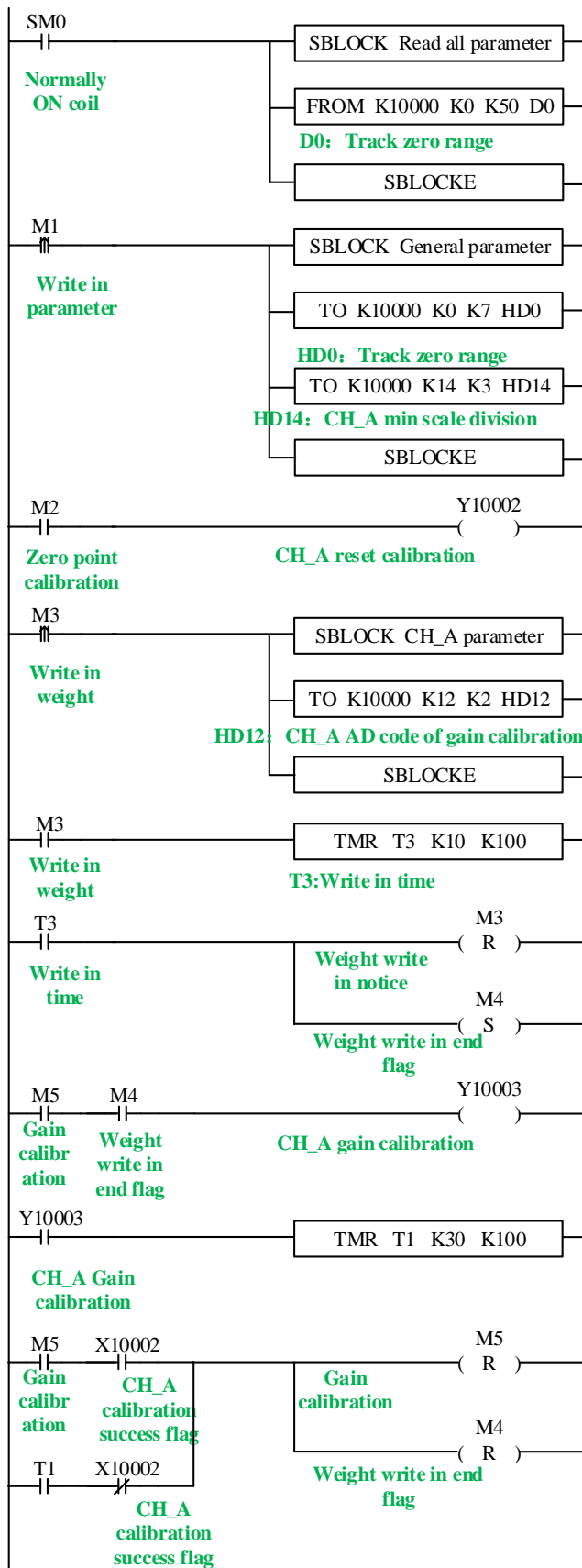

Explanation:

Read all the parameters and write in general parameters through FROM/TO instruction.

Set ON M1, write in all the parameters of channel 1.

Zero point calibration: set ON M2, if zero point calibration is successful, X10002 is set ON.

Gain calibration: first set ON M3, write the weight value HD12 to the module. After write in success flag M4 is ON, it starts to calibrate gain. Set ON M5 to start the calibration, the preset stable time is 3s. after the scale is stable, gain calibration success flag X10002 is ON or calibration time T1 reached, reset M4, M5, gain calibration is finished.

18. 2 channels pressure module XD-E2WT-B

18-1. Features

XD-E2WT-B is the expansion module of XD series PLC. It can test the voltage in the range of 0mV~10mV or the voltage signal from pressure sensor. Then it can transform the voltage to digital value through A/D transformation and do calculation.

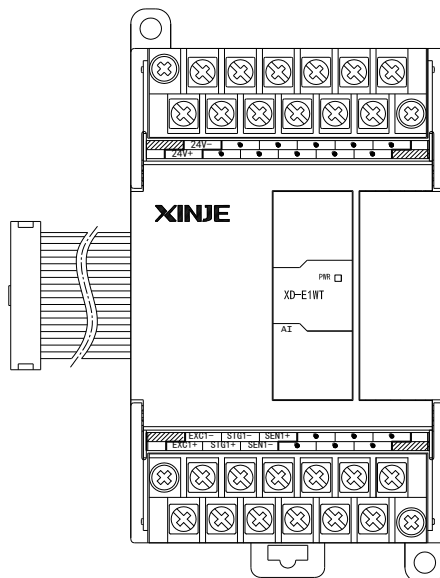

- 2 channels pressure sensor voltage signal input
- Test voltage signal in the range of 0~10mV
- 24-bit A/D transformation
- XD3 series PLC can connect 10 XD-E2WT-B modules
- XD5/XDM/XDC/XD5E series PLC can connect 16 XD-E2WT-B modules
- XD2 cannot extend modules

Input range	DC 0~10mV
Resolution	1/16777216 (24Bit)
Integrated precision	>0.01%
Transformation speed	10-200 times/second
Power supply	DC24V ±10%, 100mA
Sensor power supply	5VDC/120mA, can parallel 4 pieces of 350Ω pressure sensor
Installation	Mount on DIN46277 rail (width 35mm) or fix with screw M3
Dimension	63mm×108mm×79.9mm
Working environment	No corrosive gas
Ambient temperature	-10°C~50°C
Humidity	5~95%
Software version	V3.4 and higher version

18-2. Terminals

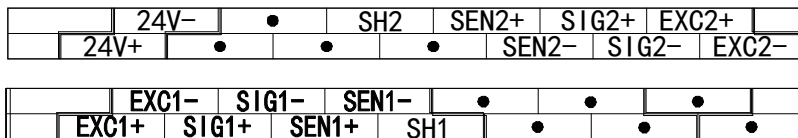

Channel	Terminal	Signal	Meaning
CH1	EXC1+	Excitation+	Connect to sensor power supply input
	EXC1-	Excitation-	
	SIG1+	Signal +	Connect to sensor signal output
	SIG1-	Signal -	
	SEN1+	Feedback +	Connect to sensor feedback voltage output
	SEN1-	Feedback -	
	SH1	Shield	Connect to sensor ground
CH2	EXC2+	Excitation+	Connect to sensor power supply input
	EXC2-	Excitation-	
	SIG2+	Signal +	Connect to sensor signal output
	SIG2-	Signal -	
	SEN2+	Feedback +	Connect to sensor feedback voltage output
	SEN2-	Feedback -	

	SH2	Shield	Connect to sensor ground
	24V	+24V power supply	Module power supply
	24V-	Common terminal	

18-3. External connection

For external connection, please note the following cases:

- Please use the 24V power supply on the PLC to avoid interference.
- Please use shield cable and single-point connect to the ground.

Power supply wiring

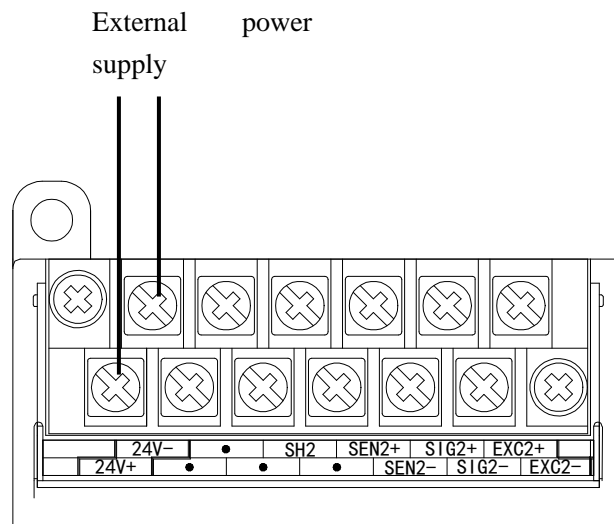

Connect to sensor

6 wires sensor:

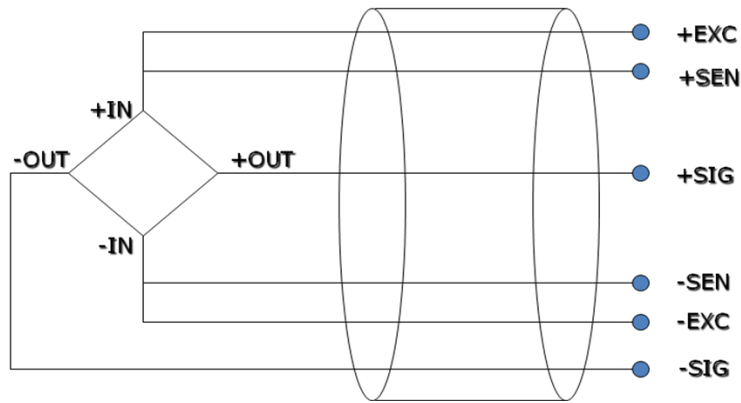

4 wires sensor:

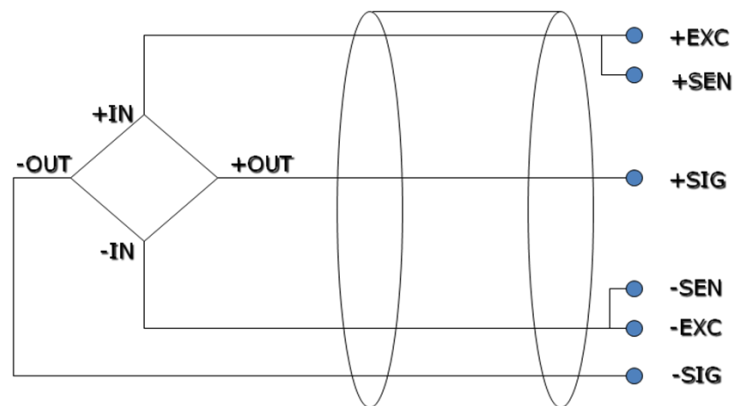

Notes: if the sensor is 4 wires mode, please connect EXC1- and SEN1-, EXC1+ and SEN1+.

18-4. Weighing system

A typical weighing system:

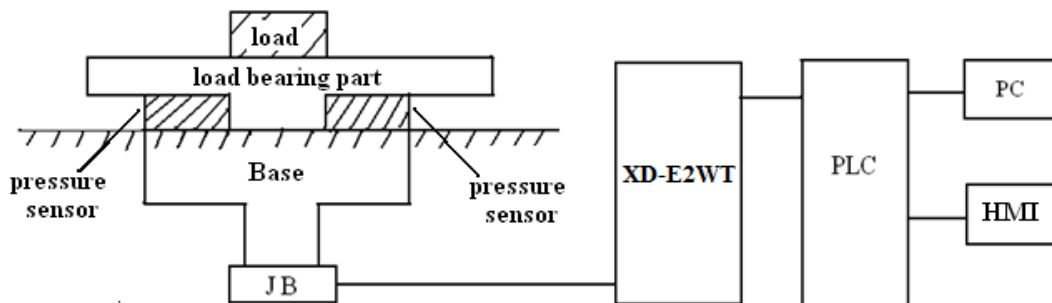

Loading bearing part: to support the load. Such as flat, hopper, container, air transport car...

Pressure sensor: transform the weight to voltage signal.

Assembly part: make sure the pressure sensor can work correctly, assembly part and direct part can avoid overload. Overload will cause measurement error and sensor damage.

Connection box (JB): to collect several sensor signals.

XD-E2WT-B: can be used as an electronic assessment device, it gets the pressure sensor signal and makes

further assessment.

18-5. Module functions

XD-E2WT-B has the follow functions:

- Adjust the pressure sensor
- Collect the pressure sensor signal
- Calculate the weight value
- 0~10mV voltage signal test

18-5-1. Pressure sensor

The pressure sensor is based on resistance strain effect, see the following diagram:

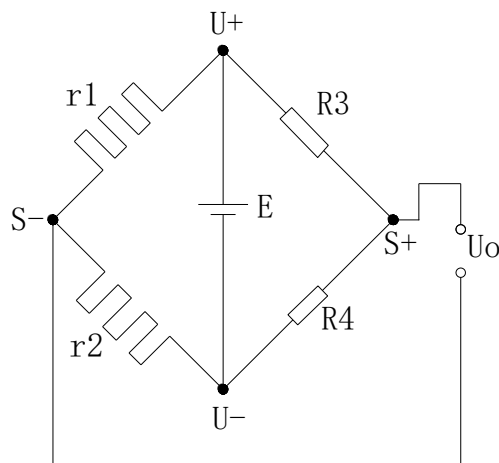

R1 and R2 is strain resistor which make bridge circuit with R3 and R4. With the change of R1 and R2, the bridge circuit will lose the balance, unbalance voltage U_o will be produced as the output of sensor.

U_+ and U_- are positive and negative point of the sensor power supply. Please select the 5V power of the module or from outside.

S_+ and S_- are positive and negative point of the sensor output. Connect the output to the module to test the weight.

18-6. I/O address

Expansion module no.1 register address

Soft component		Address	Explanation	Note
Output coil	CH1	Y10000	resonance measurement	
		Y10001	write in user-defined parameters	
		Y10002	Reset	
		Y10003	Calibration	
	CH2	Y10004	resonance measurement	

		Y10005	write in user-defined parameters	
		Y10006	Reset	
		Y10007	Calibration	
Input coil	CH1	X10000	CH1 error	
	CH1	X10001	CH1 trapped wave enable	
	CH2	X10002	CH2 error	
	CH2	X10003	CH2 trapped wave enable	
Input register	CH1	ID10000	Present digital value /CH1 resonance frequency	Dword
		ID10002	Present weight	Dword
	CH2	ID10004	Present digital value / CH2 resonance frequency	Dword
		ID10006	Present weight	Dword

Expansion module no.2 register address

Soft component		Address	Explanation	Note
Output coil	CH1	Y10100	resonance measurement	
		Y10101	write in user-defined parameters	
		Y10102	Reset	
		Y10103	Calibration	
	CH2	Y10104	resonance measurement	
		Y10105	write in user-defined parameters	
		Y10106	Reset	
		Y10107	Calibration	
Input coil	CH1	X10100	CH1 error	
	CH1	X10101	CH1 trapped wave enable	
	CH2	X10102	CH2 error	
	CH2	X10103	CH2 trapped wave enable	
Input register	CH1	ID10100	Present digital value /CH1 resonance frequency	Dword
		ID10102	Present weight	Dword
	CH2	ID10104	Present digital value / CH2 resonance frequency	Dword
		ID10106	Present weight	Dword

.....

Expansion module no.16 register address

Soft component		Address	Explanation	Note
Output coil	CH1	Y11700	resonance measurement	
		Y11701	write in user-defined parameters	
		Y11702	Reset	
		Y11703	Calibration	
	CH2	Y11704	resonance measurement	

		Y11705	write in user-defined parameters	
		Y11706	Reset	
		Y11707	Calibration	
Input coil	CH1	X11700	CH1 error	
	CH1	X11701	CH1 trapped wave enable	
	CH2	X11702	CH2 error	
	CH2	X11703	CH2 trapped wave enable	
Input register	CH1	ID11500	Present digital value /CH1 resonance frequency	Dword
		ID11502	Present weight	Dword
	CH2	ID11504	Present digital value / CH2 resonance frequency	Dword
		ID11506	Present weight	Dword

18-7. Working mode

There are two modes to set the working mode:

1. set through the control panel
2. set through the Flash register

Open the PLC software, click configure/expansion module settings:

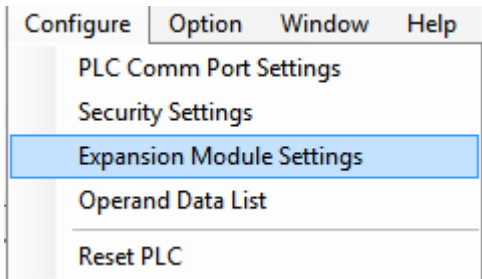

Choose suitable model information:

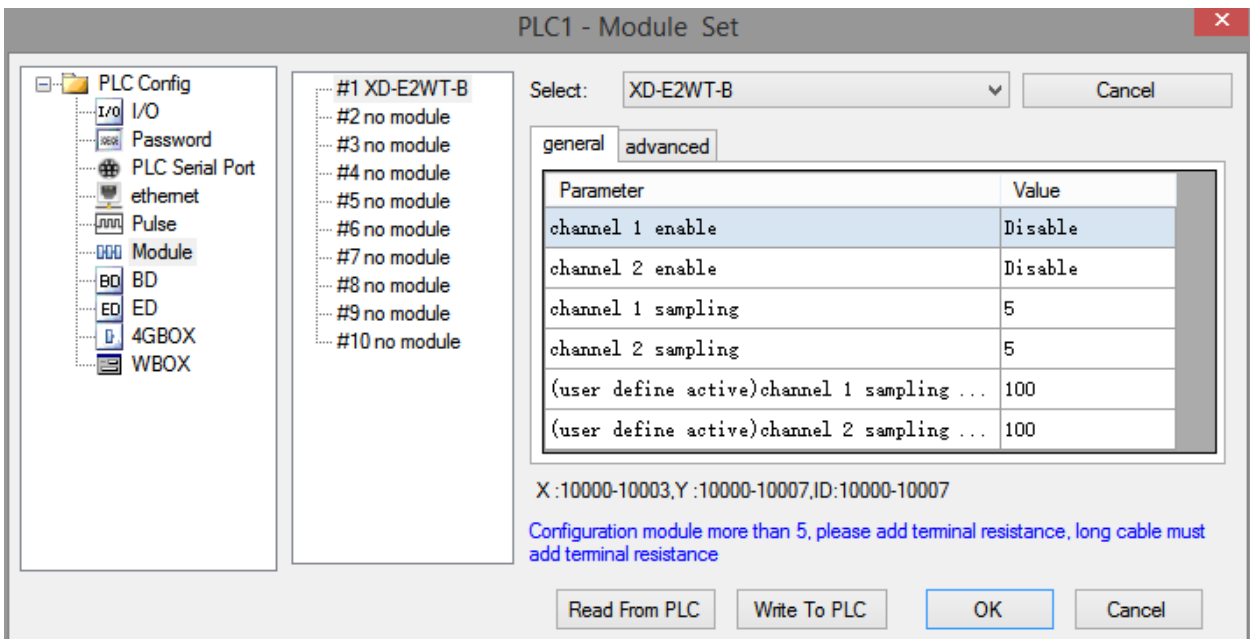

Flash register setting:

The expansion module can set gear and user-defined fast sampling frequency through the PLC internal flash register SFD.

Module no.	SFD address	Module no.	SFD address
#1	SFD350~SFD359	#9	SFD430~SFD439
#2	SFD360~SFD369	#10	SFD440~SFD449
#3	SFD370~SFD379	#11	SFD450~SFD459
#4	SFD380~SFD389	#12	SFD460~SFD469
#5	SFD390~SFD399	#13	SFD470~SFD479
#6	SFD400~SFD409	#14	SFD480~SFD489
#7	SFD410~SFD419	#15	SFD490~SFD499
#8	SFD420~SFD429	#16	SFD500~SFD509

SFD350~SFD359 register explanation:

SFD	Bit7	Bit6	Bit5	Bit4	Bit3	Bit2	Bit1	Bit0	
SFD350	Byte0		CH2 enable	CH1 enable					
	Byte1	CH2 fast sampling gear (0-12)			CH1 fast sampling gear (0-12)				
SFD351	Byte2								
	Byte3	CH1 user-defined fast sampling speed (Hz) (10-200)							
SFD352	Byte4	CH2 user-defined fast sampling speed (Hz) (10-200)							
	Byte5								
SFD353	Byte6								
	Byte7								
SFD354	Byte8								
	Byte9								
SFD355	Byte10								
	Byte11								
SFD356	Byte12								

	Byte13		
SFD357	Byte14		
	Byte15		
SFD358	Byte16		
	Byte17		
SFD359	Byte18		
	Byte19		

18-8. Module setting

Take module no.1 channel 1 as an example:

Module parameter setting:

When the PLC sampling gear is set to 12, PLC will write in the parameters through the TO instruction. Other gears are fixed parameters, cannot be changed.

The parameter list:

FromToData	Explanation	
K0	CH1 calibration weight	Dword
K2	CH1 mean filtering width (0-50)	Word
K3	CH1 median filtering width	Word
K4	CH1 Kalman filtering depth (0-200)	Word
K5	CH1 first order filter gear (0-6)	Word
K6	CH1 filter attenuation multiple (0-40)	Word
K7	CH1 user error code	Word
K8	CH2 calibration weight	Dword
K10	CH2 mean filtering width (0-50)	Word
K11	CH2 median filtering width	Word
K12	CH2 Kalman filtering depth (0-200)	Word
K13	CH2 first order filter gear (0-6)	Word
K14	CH2 filter attenuation multiples	Word
K15	CH2 user error code	Word

Default gear list:

Speed gear	Mean filtering width	Median filtering width	Kalman filtering depth	First order lag gear	Trapped wave attenuation multiples
0	3	0	0	1	0
1	3	3	0	1	0
2	5	5	40	2	2
3	8	7	0	2	20
4	10	9	0	2	30
5	12	10	0	3	40

6	15	12	20	3	40
7	20	15	20	3	40
8	12	10	20	2	30
9	15	10	20	3	30
10	15	12	20	4	30
11	15	15	40	4	40

Weight unit setting:

Write in weight through instruction TO. For example, the object weight is 1kg, write in 1 means the unit is kg, write in 1000 means the unit is g, write in 10000 means the unit is 0.1g.

Resonance frequency measurement:

1. resonance frequency is the fixed vibration interference generated by machine, it will be tested when installing the machine at the beginning.
2. repower on the module, confirm the parameters are set.
3. set ON Y10000, module will automatically measure the resonance frequency, monitor the ID10000, if it shows the measuring frequency, set OFF Y10000.

Calibration:

Please calibrate the pressure sensor for the first time using.

Take module channel 1 as an example:

1. make sure the module connected to the weighting system. Please check if the value in ID10000 fluctuated(the fluctuation range is related to sensor range), the pressure value is increasing as the load increasing. If ID10000 has no value, please check the sensor wiring. If the pressure value is decreasing as the load increasing, the sensor positive and negative point may connect backward.
2. make the pressure sensor without load, set to zero after the scale is stable, set ON Y10002(set to zero enable bit).
3. put the load on the scale, write in the load weight by instruction TO, calibrate the system after the scale is stable, set ON Y10003(calibration enable bit). The calibration completed when ID10002 is same to the load weight, set OFF Y10003.
4. Hereto, the calibration finished. The module will automatic adjust the result according to the idle load value and calibration value when weighing, and finally get the correct weight.

18-9. Instruction FROM and TO

Write instruction TO

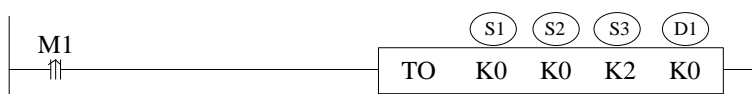

Function: write the PLC register data to module specified address, the unit is word.

Operand:

S1: target module number. Operand: K, TD, CD, D, FD.

S2: module first address. Operand: K, TD, CD, D, FD.
 S3: write in register quantity. Operand: K, TD, CD, D, FD.
 D1: write in data first address in PLC.

Read instruction FROM

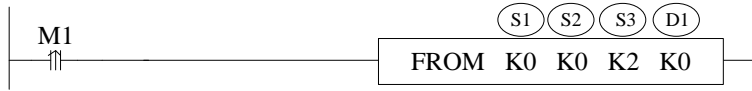

Function: read the module data to PLC register, the unit is word.

Operand:

S1: target module number. Operand: K, TD, CD, D, FD.
 S2: module first address. Operand: K, TD, CD, D, FD.
 S3: read register quantity. operand: K, TD, CD, D, FD.
 D1: PLC register first address.

Note: FROM and TO only can be added in sequence block, one program only can add 8 sequence blocks.

18-10. A/D transformation diagram

The relationship between input voltage value and A/D transformed digital value:

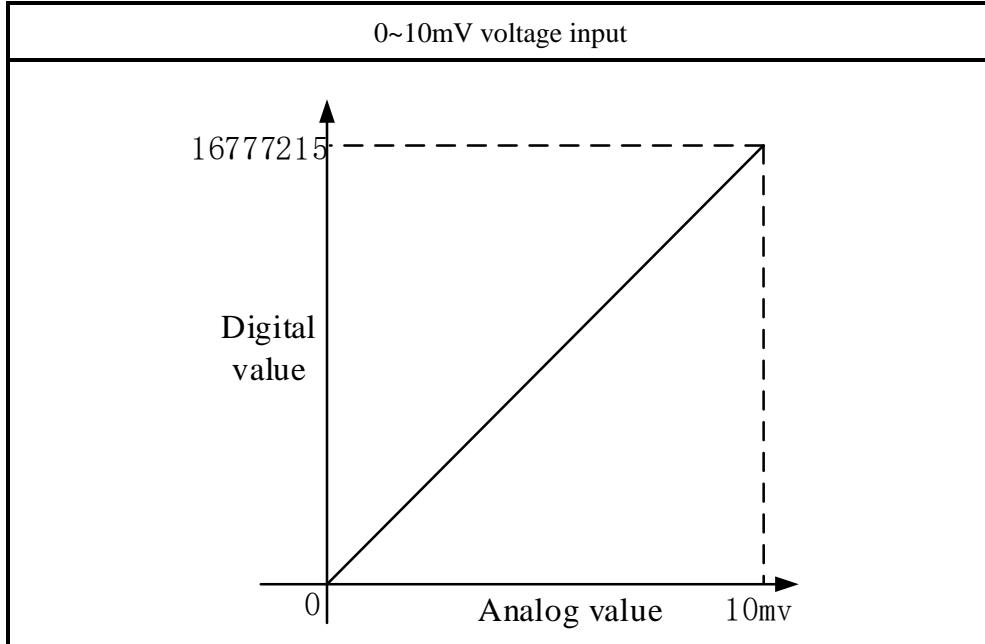

18-11. Application program

Take module 1 channel 1 as an example:

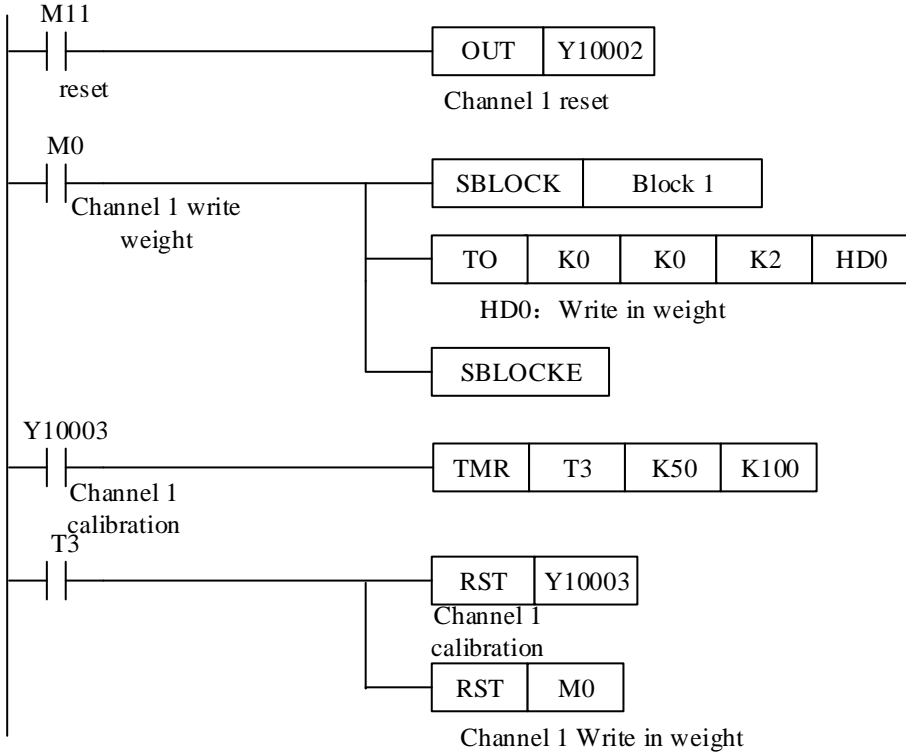

Explanation:

Set to zero through Y10002.
 Write in the weight value through instruction TO. First store the weight value in HD0, set ON M0, write the value of HD0 to module 1 channel 1.
 Calibrate the scale through Y10003. The calibration is finished when the weight value is equal to the weight display value.

19. 1 channels pressure module XD-E1WT-C

19-1. Features

XD-E1WT-C is the expansion module of XD series PLC. It can test the voltage in the range of 0~10mV or the voltage signal from pressure sensor. Then it can transform the voltage to digital value through A/D transformation and do calculation.

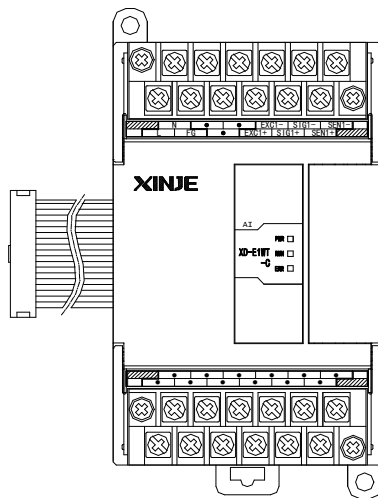

- 1 channel pressure sensor voltage signal input
- Test voltage signal in the range of 0~10mV
- 24-bit A/D transformation
- XD3 series PLC can connect 10 XD-E1WT-C modules
- XDM/XD5/XDC/XD5E series PLC can connect 16 XD-E1WT-C modules

Input range	DC 0~10mV (sensor 2mv/v)
AD real resolution	1/1048575 (20bit)
Max display resolution	1/300000
Non-linear	0.01%F.S
Transformation speed	150/300/450times/second (optional)
Power supply	AC220V \pm 10% 50/60Hz
Sensor power supply	5VDC/120mA, can parallel 4 pieces of 350 Ω pressure sensor
Dimension	63mm \times 108mm \times 89.9mm
Installation	Mount on DIN46277 rail (width 35mm) or fix with screw M3
Software version	V3.5.1 and higher version
Working environment	No corrosive gas
Ambient temperature	-10 $^{\circ}$ C~50 $^{\circ}$ C
Humidity	5~95%RH (no condensation)

19-2. Terminals

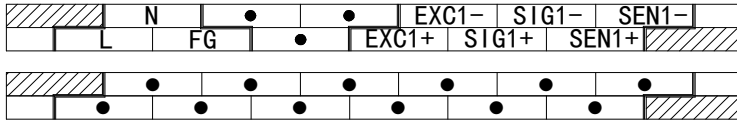

Channel	Terminal	Signal	Meaning
CH1	EXC1+	Excitation +	Connect to sensor power supply input
	EXC1-	Excitation -	
	SIG1+	Signal +	Connect to sensor signal output
	SIG1-	Signal -	
	SEN1+	Feedback +	Connect to sensor feedback voltage output
	SEN1-	Feedback -	
	SH1	Shield	Connect to sensor ground terminal
-	L, N	Module power supply	Give power to module, AC220V ± 10% 50/60Hz
	FG	Power supply ground	Connect to ground

19-3. External connection

Please use shield cable and single-point connect to the ground for shield layer.

Power supply wiring

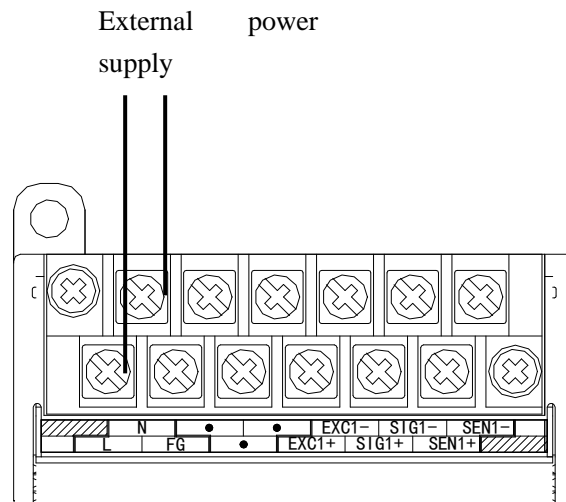

Connect to sensor

6 wires mode:

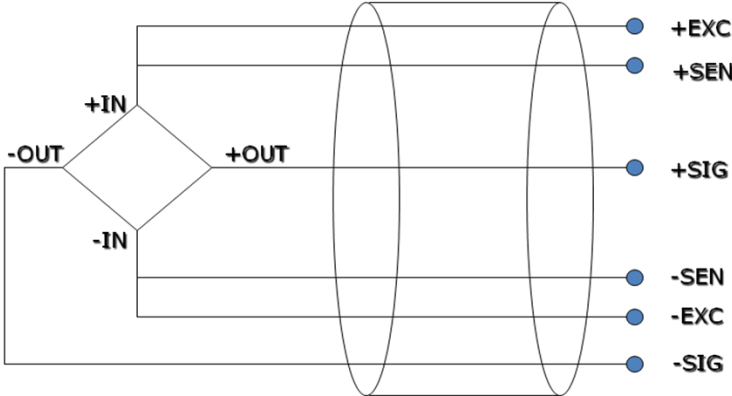

4 wires mode:

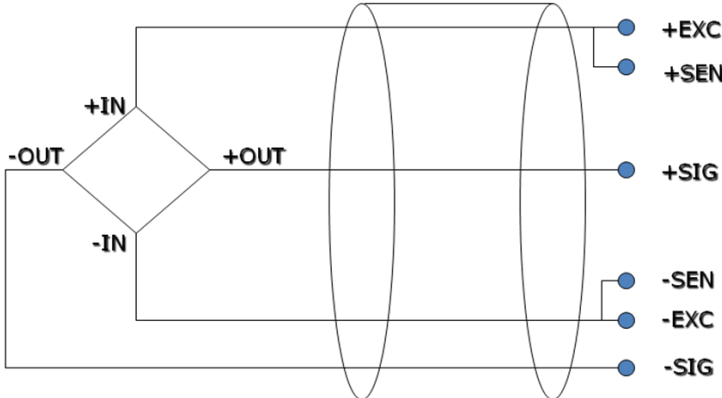

Note: short connect EXC1- and SEN1-, short connect EXC1+ and SEN1+ for 4 wires mode sensor.

19-4. Weighing system

A typical weighing system:

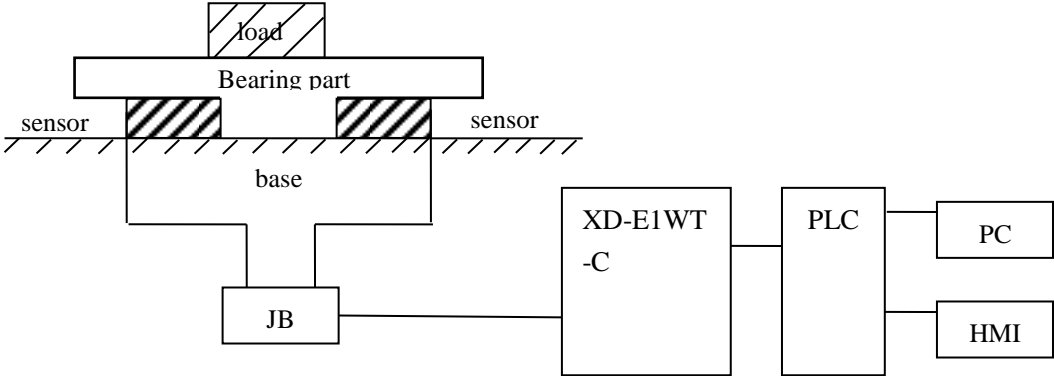

Loading bearing part: to support the load. Such as flat, hopper, container, air transport car...

Pressure sensor: transform the weight to voltage signal.

Assembly part: make sure the pressure sensor can work correctly, assembly part and direct part can avoid overload. Overload will cause measurement error and sensor damage.

Connection box (JB): to collect several sensor signals.

XD-E1WT-C: can be used as an electronic assessment device, it gets the pressure sensor signal and makes further assessment.

19-5. Module functions

XD-E1WT-C has the follow functions:

- Adjust the pressure sensor
- Collect the pressure sensor signal
- Calculate the weight value
- 0~10mV voltage signal test

19-5-1. Pressure sensor

The pressure sensor is based on resistance strain effect, see the following diagram:

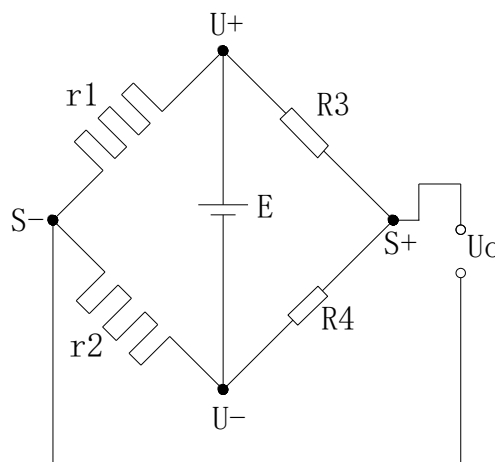

R1 and R2 is strain resistor which make bridge circuit with R3 and R4. With the change of R1 and R2, the bridge circuit will lose the balance, unbalance voltage U_o will be produced as the output of sensor.

U+ and U- are positive and negative point of the sensor power supply. Please select the 5V power of the module or from outside.

S+ and S- are positive and negative point of the sensor output. Connect the output to the module to test the weight.

19-6. I/O address

The I/O address of module 1:

Soft component		Address	Explanation	Note
Output coil	CH1	Y10000	Filter level	
		Y10001	Reset	
		Y10002	Zero point calibration	
		Y10003	Gain calibration	
	ALL	Y10020	Back to out of factory value	
Input coil	CH1	X10000	Stable flag	
		X10001	Overflow flag	
		X10002	Calibration success flag	
		X10003	Calibration failure flag	
Input register	CH1	ID10000	Present weight	Double words
		ID10002	Present digital value/present input voltage	Double words

The I/O address of module 2:

Soft component		Address	Explanation	Note
Output coil	CH1	Y10100	Filter level	
		Y10101	Reset	
		Y10102	Zero point calibration	
		Y10103	Gain calibration	
	ALL	Y10120	Back to out of factory value	
Input coil	CH1	X10100	Stable flag	
		X10101	Overflow flag	
		X10102	Calibration success flag	
		X10103	Calibration failure flag	
Input register	CH1	ID10100	Present weight	Double words
		ID10102	Present digital value/present input voltage	Double words

.....

The I/O address of module 16:

Soft component		Address	Explanation	Note
Output coil	CH1	Y11500	Filter level	
		Y11501	Reset	

		Y11502	Zero point calibration	
		Y11503	Gain calibration	
	ALL	Y10020	Back to out of factory value	
Input coil	CH1	X11500	Stable flag	
		X11501	Overflow flag	
		X11502	Calibration success flag	
		X11503	Calibration failure flag	
Input register	CH1	ID11500	Present weight	Double words
		ID11502	Present digital value/present input voltage	Double words

Address explanation:

filter level	ON: filter level A, OFF: filter level B
Reset	The reset is valid in the reset range, not save zero point
zero point calibration	To calibrate the system zero point
gain calibration	To calibrate system linear
Stable flag	The signal output is effective when meeting the stable range and time
Overflow flag	When the signal voltage larger than 10mv, this signal output is effective
Calibration success flag	This signal output is effective when zero point calibration and gain calibration succeeded
Calibration failure flag	This signal output is effective when zero point calibration and gain calibration failed (the detailed reasons please check module applicatoin error info)
Present digital value/present input voltage	Switch through upper device, when it is switched to present input voltage, the unit is mv, the decimal place is 4 bits

19-7. Working mode

There are two method to set the working mode:

1. set through the control panel
2. set through Flash register

Open the XD PLC software, click the menu configure/expansion module setting.

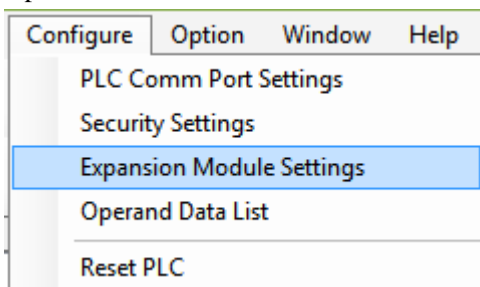

Choose the correct model and configuration information:

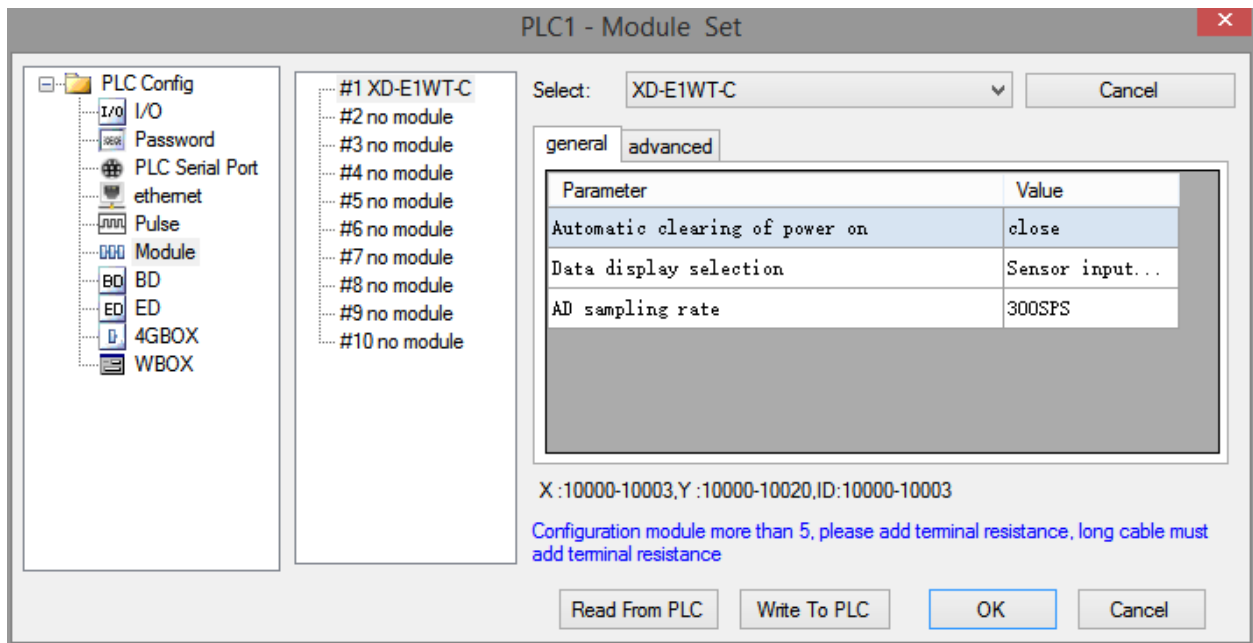

Flash register setting:

The expansion module can set the gear and user-defined fast sampling frequency through PLC flash register SFD.

Module no.	SFD address	Module no.	SFD address
#1	SFD350~SFD359	#9	SFD430~SFD439
#2	SFD360~SFD369	#10	SFD440~SFD449
#3	SFD370~SFD379	#11	SFD450~SFD459
#4	SFD380~SFD389	#12	SFD460~SFD469
#5	SFD390~SFD399	#13	SFD470~SFD479
#6	SFD400~SFD409	#14	SFD480~SFD489
#7	SFD410~SFD419	#15	SFD490~SFD499
#8	SFD420~SFD429	#16	SFD500~SFD509

SFD350~SFD359 register explanation:

SFD	Bit7	Bit6	Bit5	Bit4	Bit3	Bit2	Bit1	Bit0	N O T E	
SFD350	Byte0	AD sampling speed Range 0~2 Initial value: 1 0: 150 time/second 1: 300 time/second 2: 450 time/second						Sampling data mode Initial value: 0 0: sensor input voltage (mv) 1: AD sampling digital value	Automatical reset when power on Initial value: 0 0: OFF 1: ON	All the channels
	Byte1									
SFD351	Byte2									
	Byte3									
SFD352	Byte4									
	Byte5									
SFD353	Byte6									
	Byte7									
SFD354	Byte8									
	Byte9									
SFD355	Byte10									
	Byte11									
SFD356	Byte12									
	Byte13									
SFD357	Byte14									
	Byte15									
SFD358	Byte16									
	Byte17									
SFD359	Byte18									
	Byte19									

19-8. Module setting

Module parameter list:

Address	Contents	Explanation		Features
K0	Zero point tracking range	Range: 0~9 Initial value: 5	All the channels	Word R/W
K1	Zero point tracking time	Range: 500~5000 (ms) Initial value: 2000		Word R/W

K2	Reset range	Range: 1~99 (%) Initial value: 50		Word R/W
K3	Stable range	Range: 1~99 Initial value: 3		Word R/W
K4	Stable time	Range: 10~5000 (ms) Initial value: 100		Word R/W
K5	Filter level A	Range: 0~9 Initial value: 3		Word R/W
K6	Filter level B	Range: 0~9 Initial value: 5		Word R/W
K7~K9	Reserved			
K10	Zero point calibration voltage return value	Return the present sensor input voltage after calibrating the zero point	CH1	Dword R
K12	Gain calibration digital value/gain calibration voltage return value	As weight input value for gain calibration. As return relative voltage for non-calibration		Dword R/W
K14	CH1 min scale division	Range: 1,2,5,10,20,50		Word R/W
K15	CH1 max range	Range: <1000000		Dword R/W
K17	Reserved			
K20	Zero calibration voltage return value	Return the present sensor input voltage after calibrating the zero point	CH2	Dword R
K22	Gain calibration value/gain calibration voltage return value	As weight input value for gain calibration. As return relative voltage for non-calibration		Dword R/W
K24	CH2 min scale division	Range: 1,2,5,10,20,50		Word R/W
K25	CH2 max range	Range: <1000000		Dword R/W
K27	Reserved			
K30	Zero calibration voltage return value	Return the present sensor input voltage after calibrating the zero point		Dword R
K32	Gain calibration value/gain calibration voltage return value	As weight input value for gain calibration. As return relative voltage for non-calibration	CH3	Dword R/W
K34	CH3 min scale division	Range: 1,2,5,10,20,50		Word R/W
K35	CH3 max range	Range: <1000000		Dword R/W
K37	Reserved			
K40	Zero calibration voltage return value	Return the present sensor input voltage after calibrating the zero point	CH4	Dword R
K42	Gain calibration value/gain calibration	As weight input value for gain calibration. As return relative voltage		Dword R/W

	voltage return value	for non-calibration		
K44	CH4 min scale division	Range: 1,2,5,10,20,50		Word R/W
K45	CH4 max range	Range: <1000000		Dword R/W
K47	Reserved			

Take module no.1 as an example:

Weight unit setting:

Write in weight through instruction TO. For example, the object weight is 1kg, write in 1 means the unit is kg, write in 1000 means the unit is g, write in 10000 means the unit is 0.1g. resolution=1kg/write in digital value.

Calibration:

Please calibrate the pressure sensor for the first time using.

Take module channel 1 as an example:

1. confirm whether the module and sensor work properly.

Judgment method:

First, monitor whether the overflow flag X10001 is OFF state. If it is ON, the sensor is not connected or the sensor is damaged.

Second, using the software to monitor whether ID10002 value fluctuates following sensor (fluctuation range is related to sensor range), and pressure value increased when increasing the load, if there are value but increase the load stress value decreases, that means (1) sensor installed opposite, please adjust the sensor position or exchange +/- of sensor output signal; (2) The incoming voltage signal has been overflow, reducing the load appropriately.

2. Make the sensor no load, after the stable flag X10000 is ON, set ON zero point calibration Y10002. X10002 ON means the zero point calibration is successful. If after few seconds, X10003 is ON, that means zero point calibration is failed.

3. Put the load whose weight is known on the scale, write the weight through TO instruction, after stable flag X10000 is ON, set ON gain calibration Y10003, X10002 ON means calibration is successful, shut off Y10003. If after few seconds, X10003 is ON, that means zero point calibration is failed.

4. Hereto, the calibration finished. The module will automatic adjust the result according to the idle load value and calibration value when weighing, and finally get the correct weight.

19-9. Module error info

Serious application error (related to main unit register address SD503 high 8 bits)

Error code			Meaning
Binary	Hex	Decimal	
0000 0001	0x01	1	Not connect 24V
0000 0010	0x02	2	Not finish the setting in 5s
0000 0011	0x03	3	Module model is different
0000 0011	0x04	4	Communicate with PLC error

The error code using method: write in module no. in SD500, if it needs to check module no.1 error code, please write in 10000.

19-10. Instruction FROM and TO

Write instruction TO

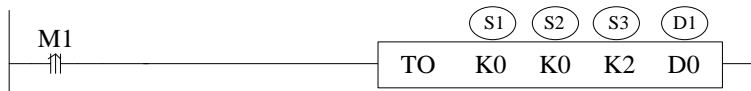

Function: write the PLC register data to module specified address, the unit is word.

Operand:

S1: target module number. Operand: K, TD, CD, D, HD, FD.

S2: module first address. Operand: K, TD, CD, D, HD, FD.

S3: write in register quantity. Operand: K, TD, CD, D, HD, FD.

D1: write in data register first address in PLC. Operand: TD, CD, D, HD, FD.

Example: write the weight value to module no.1 channel 1

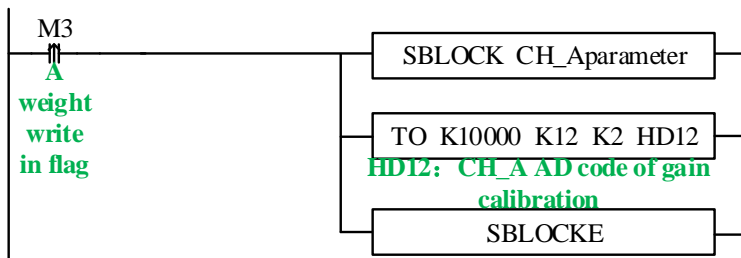

Read instruction FROM



Function: read the module data to PLC register, the unit is word.

Operand:

S1: target module number. Operand: K, TD, CD, D, HD, FD.

S2: module first address. Operand: K, TD, CD, D, HD, FD.

S3: read register quantity. Operand: K, TD, CD, D, HD, FD.

D1: PLC register first address. Operand: TD, CD, D, HD, FD.

For example: read all the parameters of module no.1

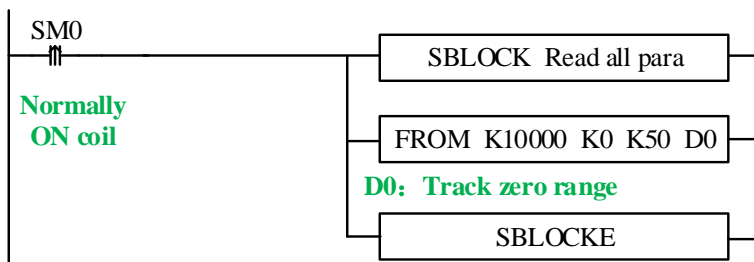

Note: FROM and TO instruction only can be added in sequence block, one program can support 100 sequence blocks. But only 8 sequence blocks can execute at the same time.

19-11. AD transformation diagram

The relationship between input analog voltage and converted digital value is shown as below:

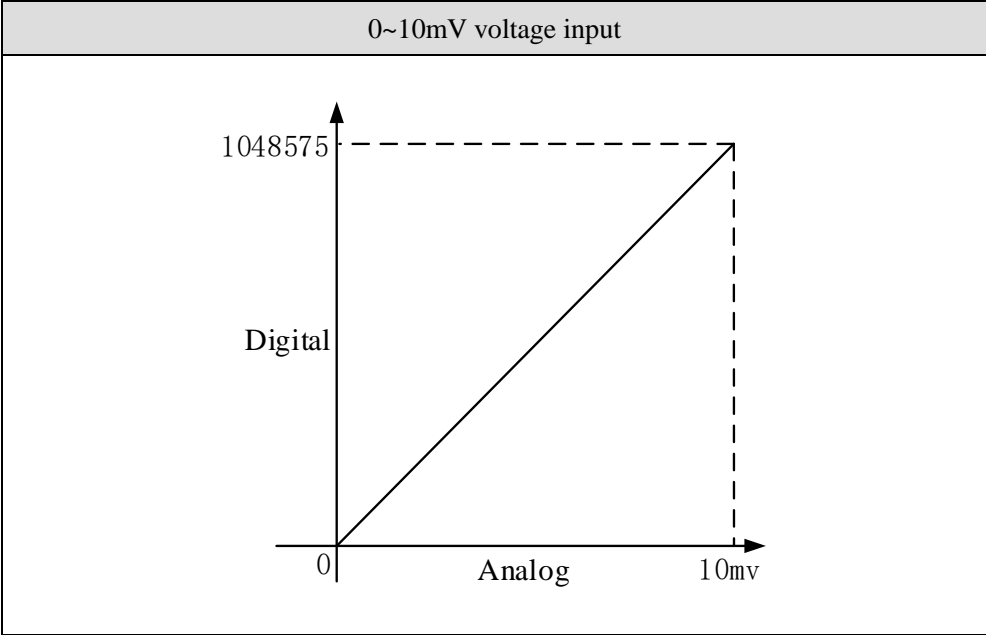

19-12. Application program

Take module 1 as an example:

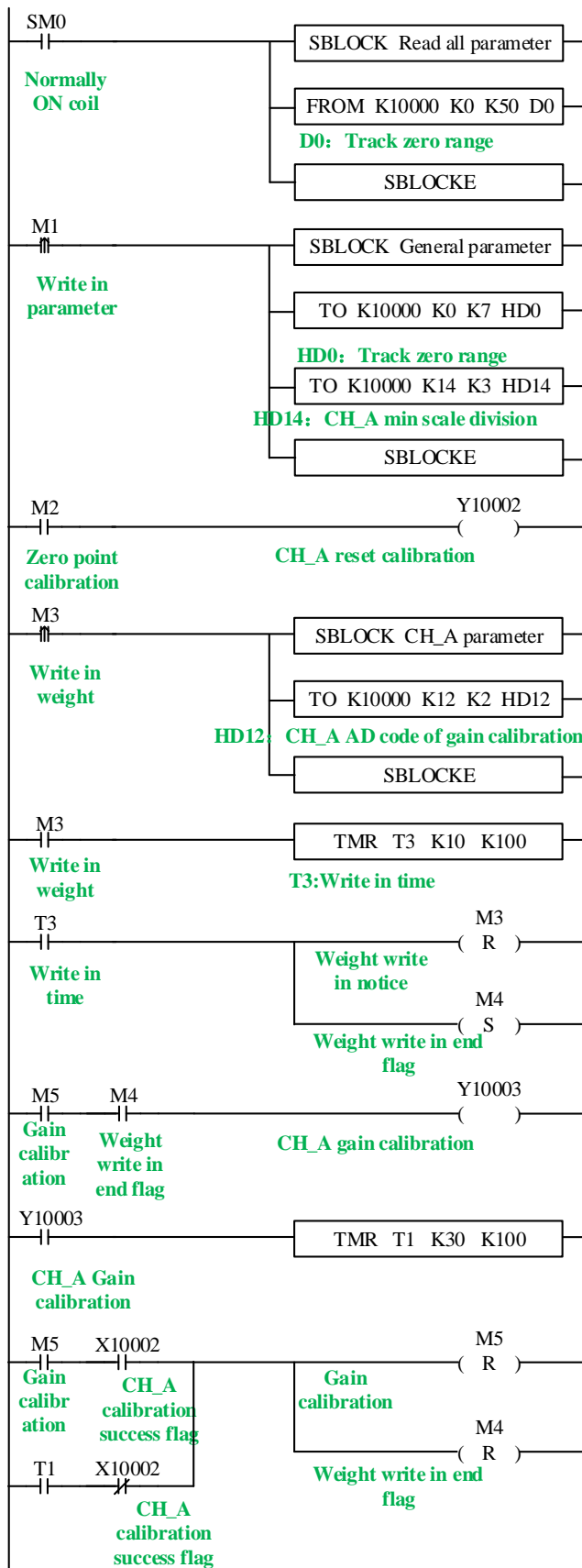

Explanation:

Read all the parameters and write in general parameters through FROM/TO instruction.

Set ON M1, write in all the parameters of channel 1.

Zero point calibration: set ON M2, if zero point calibration is successful, X10002 is set ON.

Gain calibration: first set ON M3, write the weight value HD12 to the module. After write in success flag M4 is ON, it starts to calibrate gain. Set ON M5 to start the calibration, the preset stable time is 3s. after the scale is stable, gain calibration success flag X10002 is ON or calibration time T1 reached, reset M4, M5, gain calibration is finished.

20. 2 channels pressure module XD-E2WT-C

20-1. Features

XD-E2WT-C is the expansion module of XD series PLC. It can test the voltage in the range of 0~10mV or the voltage signal from pressure sensor. Then it can transform the voltage to digital value through A/D transformation and do calculation.

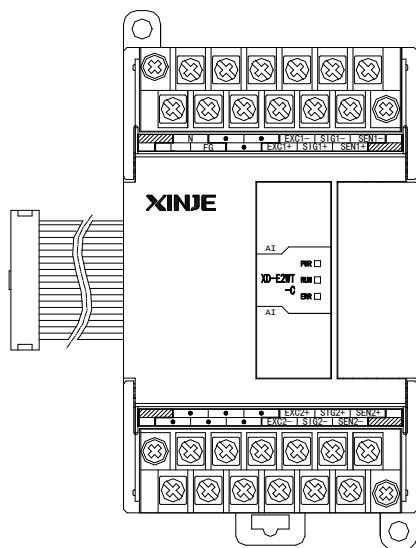

- 2 channel pressure sensor voltage signal input
- Test voltage signal in the range of 0~10mV
- 24-bit A/D transformation
- XD3 series PLC can connect 10 XD-E2WT-C modules
- XDM/XD5/XDC/XD5E series PLC can connect 16 XD-E2WT-C modules

Input range	DC 0~10mV (sensor 2mv/v)
AD real resolution	1/1048575 (20bit)
Max display resolution	1/300000
Non-linear	0.01%F.S
Transformation speed	150/300/450times/second (optional)
Power supply	AC220V ± 10% 50/60Hz
Sensor power supply	5VDC/120mA, can parallel 4 pieces of 350Ω pressure sensor
Dimension	63mm×108mm×89.9mm
Installation	Mount on DIN46277 rail (width 35mm) or fix with screw M3
Software version	V3.5.1 and higher version
Working environment	No corrosive gas
Ambient temperature	-10°C~50°C
Humidity	5~95%RH (no condensation)

20-2. Terminals

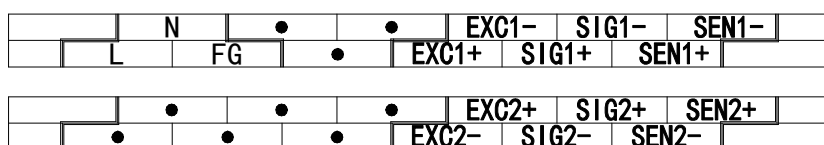

Channel	Terminal	Signal	Meaning
CH1	EXC1+	Excitation +	Connect to sensor power supply input
	EXC1-	Excitation -	
	SIG1+	Signal +	Connect to sensor signal output
	SIG1-	Signal -	
	SEN1+	Feedback +	Connect to sensor feedback voltage output
	SEN1-	Feedback -	
	SH1	Shield	Connect to sensor ground terminal
CH2	EXC2+	Excitation +	Connect to sensor power supply input
	EXC2-	Excitation -	
	SIG2+	Signal +	Connect to sensor signal output
	SIG2-	Signal -	
	SEN2+	Feedback +	Connect to sensor feedback voltage output
	SEN2-	Feedback -	
	SH2	Shield	Connect to sensor ground terminal
-	L, N	Module power	Give power to the module, AC220V ±

		supply	10% 50/60Hz
	FG	Power supply ground	Ground terminal

20-3. External connection

Please use shield cable and single-point connect to the ground for shield layer.

Power supply wiring

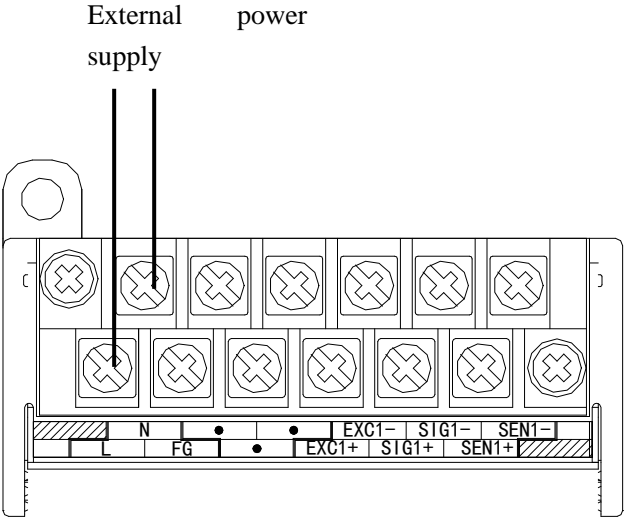

Connect to sensor

6 wires mode:

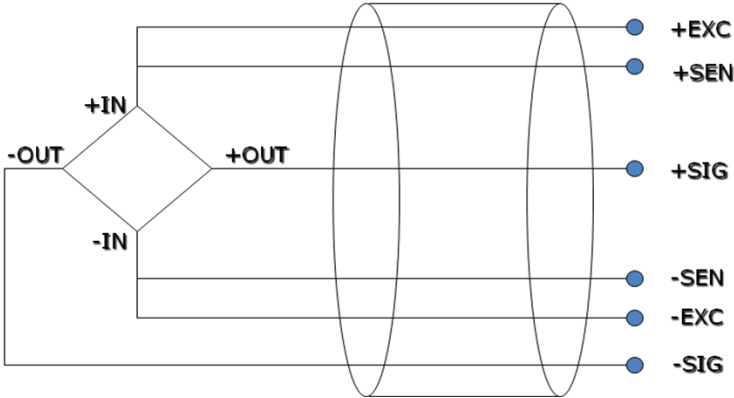

4 wires mode:

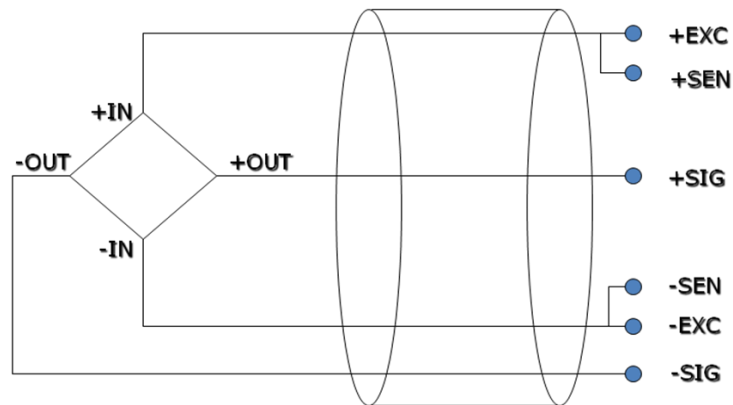

Note: short connect EXC1- and SEN1-, short connect EXC1+ and SEN1+ for 4 wires mode sensor.

20-4. Weighing system

A typical weighing system:

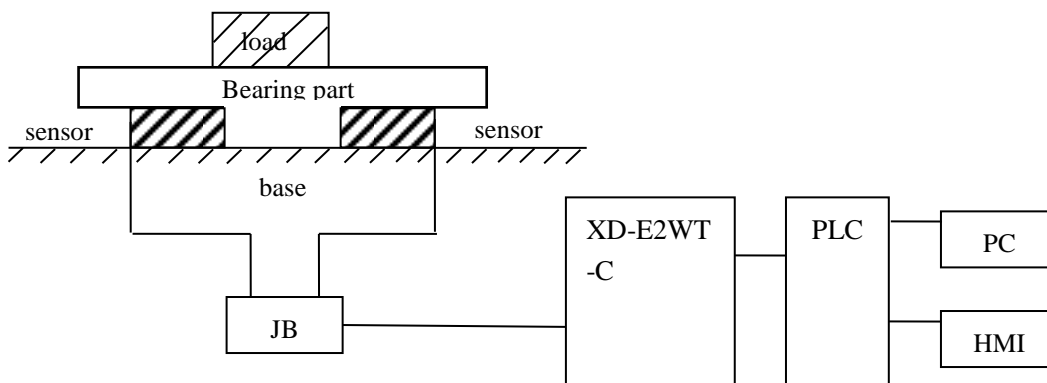

Loading bearing part: to support the load. Such as flat, hopper, container, air transport car...

Pressure sensor: transform the weight to voltage signal.

Assembly part: make sure the pressure sensor can work correctly, assembly part and direct part can avoid overload. Overload will cause measurement error and sensor damage.

Connection box (JB): to collect several sensor signals.

XD-E2WT-C: can be used as an electronic assessment device, it gets the pressure sensor signal and makes further assessment.

20-5. Module functions

XD-E2WT-C has the follow functions:

- Adjust the pressure sensor
- Collect the pressure sensor signal
- Calculate the weight value
- 0~10mV voltage signal test

20-5-1. Pressure sensor

The pressure sensor is based on resistance strain effect, see the following diagram:

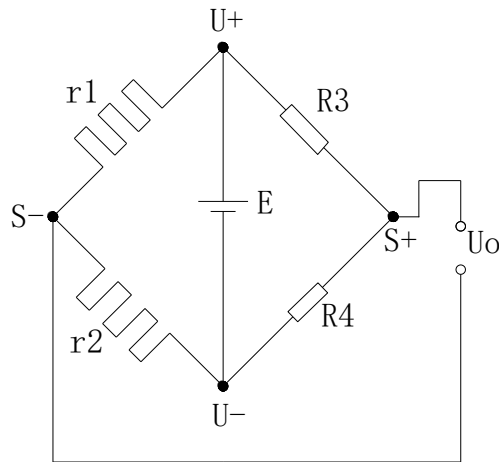

R1 and R2 is strain resistor which make bridge circuit with R3 and R4. With the change of R1 and R2, the bridge circuit will lose the balance, unbalance voltage U_o will be produced as the output of sensor.

U+ and U- are positive and negative point of the sensor power supply. Please select the 5V power of the module or from outside.

S+ and S- are positive and negative point of the sensor output. Connect the output to the module to test the weight.

20-6. I/O address

The I/O address of module 1:

Soft component		Address	Explanation	Note
Output coil	CH1	Y10000	Filter level	
		Y10001	Reset	
		Y10002	Zero point calibration	
		Y10003	Gain calibration	
	CH2	Y10004	Filter level	
		Y10005	Reset	
		Y10006	Zero point calibration	
		Y10007	Gain calibration	
	ALL	Y10020	Back to out of factory value	
	Input coil	CH1	X10000	Stable flag
X10001			Overflow flag	
X10002			Calibration success flag	
X10003			Calibration failure flag	
CH2		X10004	Stable flag	
		X10005	Overflow flag	
		X10006	Calibration success flag	

		X10007	Calibration failure flag	
Input register	CH1	ID10000	Present weight	Double words
		ID10002	Present digital value/present input voltage	Double words
	CH2	ID10004	Present weight	Double words
		ID10006	Present digital value/present input voltage	Double words

The I/O address of module 2:

Soft component		Address	Explanation	Note
Output coil	CH1	Y10100	Filter level	
		Y10101	Reset	
		Y10102	Zero point calibration	
		Y10103	Gain calibration	
	CH2	Y10104	Filter level	
		Y10105	Reset	
		Y10106	Zero point calibration	
		Y10107	Gain calibration	
ALL	Y10120	Back to out of factory value		
Input coil	CH1	X10100	Stable flag	
		X10101	Overflow flag	
		X10102	Calibration success flag	
		X10103	Calibration failure flag	
	CH2	X10104	Stable flag	
		X10105	Overflow flag	
		X10106	Calibration success flag	
		X10107	Calibration failure flag	
Input register	CH1	ID10100	Present weight	Double words
		ID10102	Present digital value/present input voltage	Double words
	CH2	ID10104	Present weight	Double words
		ID10106	Present digital value/present input voltage	Double words

.....

The I/O address of module 16:

Soft component		Address	Explanation	Note
Output coil	CH1	Y11500	Filter level	
		Y11501	Reset	
		Y11502	Zero point calibration	
		Y11503	Gain calibration	
	CH2	Y11504	Filter level	
		Y11505	Reset	
		Y11506	Zero point calibration	
Y11507		Gain calibration		
ALL	Y10020	Back to out of factory value		
Input coil	CH1	X11500	Stable flag	
		X11501	Overflow flag	
		X11502	Calibration success flag	
		X11503	Calibration failure flag	
	CH2	X11504	Stable flag	
		X11505	Overflow flag	
		X11506	Calibration success flag	
X11507		Calibration failure flag		
Input register	CH1	ID11500	Present weight	Double words
		ID11502	Present digital value/present input voltage	Double words
	CH2	ID11504	Present weight	Double words
		ID11506	Present digital value/present input voltage	Double words

Address explanation:

filter level	ON: filter level A, OFF: filter level B
Reset	The reset is valid in the reset range, not save zero point
zero point calibration	To calibrate the system zero point
gain calibration	To calibrate system linear
Stable flag	The signal output is effective when meeting the stable range and time
Overflow flag	When the signal voltage larger than 10mv, this signal output is effective
Calibration success flag	This signal output is effective when zero point calibration and gain calibration succeeded
Calibration failure flag	This signal output is effective when zero point calibration and gain calibration failed (the detailed reasons please check module applicatoin error info)
Present digital value/present input	Switch through upper device, when it is switched to present input voltage, the unit is mv, the decimal place is 4 bits

voltage

20-7. Working mode

There are two method to set the working mode:

1. set through the control panel
2. set through Flash register

Open the XD PLC software, click the menu configure/expansion module setting.

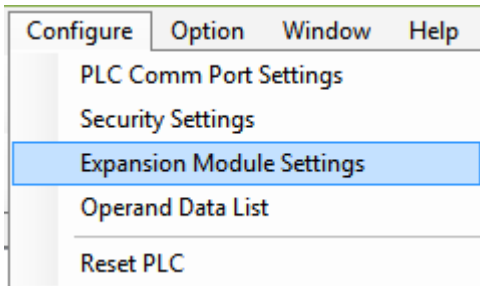

Choose the correct model and configuration information:

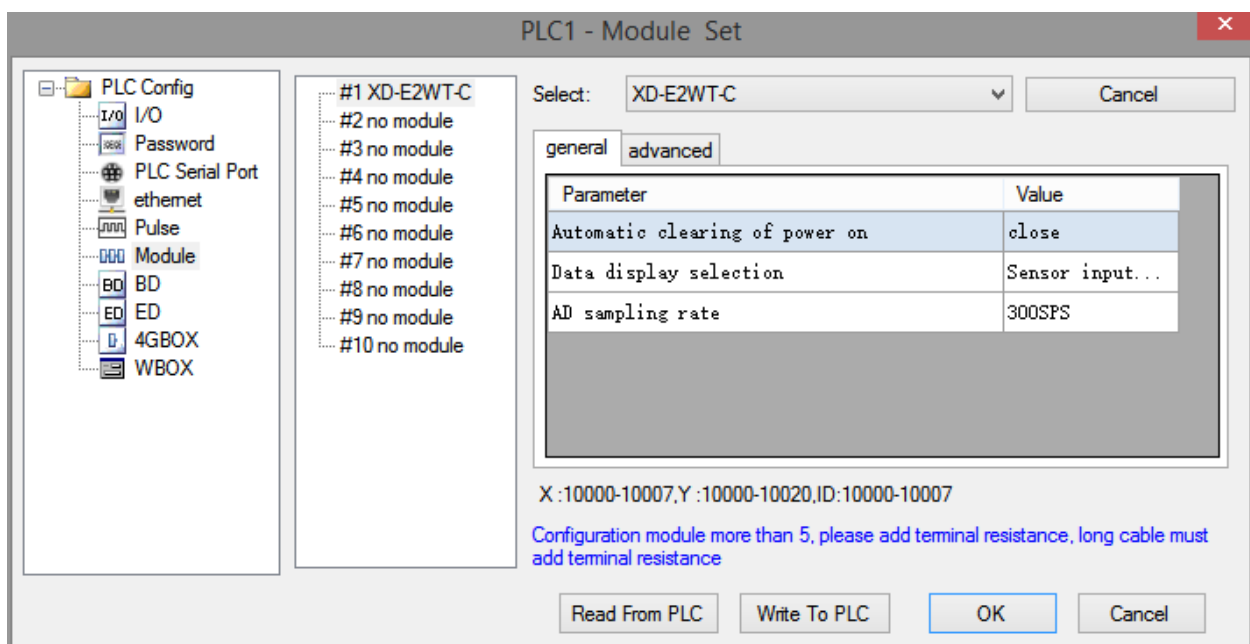

Flash register setting:

The expansion module can set the gear and user-defined fast sampling frequency through PLC flash register SFD.

Module no.	SFD address	Module no.	SFD address
#1	SFD350~SFD359	#9	SFD430~SFD439

#2	SFD360~SFD369	#10	SFD440~SFD449
#3	SFD370~SFD379	#11	SFD450~SFD459
#4	SFD380~SFD389	#12	SFD460~SFD469
#5	SFD390~SFD399	#13	SFD470~SFD479
#6	SFD400~SFD409	#14	SFD480~SFD489
#7	SFD410~SFD419	#15	SFD490~SFD499
#8	SFD420~SFD429	#16	SFD500~SFD509

SFD350~SFD359 register explanation:

SFD		Bit7	Bit6	Bit5	Bit4	Bit3	Bit2	Bit1	Bit0	NOTE	
SFD350	Byte0	AD sampling speed Range 0~2 Initial value: 1 0: 150 time/second 1: 300 time/second 2: 450 time/second						Sampling data mode Initial value: 0 0: sensor input voltage (mv) 1: AD sampling digital value	Automatical reset when power on Initial value: 0 0: OFF 1: ON		All the channels
	Byte1										
SFD351	Byte2										
	Byte3										
SFD352	Byte4										
	Byte5										
SFD353	Byte6										
	Byte7										
SFD354	Byte8										
	Byte9										
SFD355	Byte10										
	Byte11										
SFD356	Byte12										
	Byte13										
SFD357	Byte14										

	Byte15		
SFD358	Byte16		
	Byte17		
SFD359	Byte18		
	Byte19		

20-8. Module setting

Module parameter list:

Address	Contents	Explanation		Features
K0	Zero point tracking range	Range: 0~9 Initial value: 5	All the channels	Word R/W
K1	Zero point tracking time	Range: 500~5000 (ms) Initial value: 2000		Word R/W
K2	Reset range	Range: 1~99 (%) Initial value: 50		Word R/W
K3	Stable range	Range: 1~99 Initial value: 3		Word R/W
K4	Stable time	Range: 10~5000 (ms) Initial value: 100		Word R/W
K5	Filter level A	Range: 0~9 Initial value: 3		Word R/W
K6	Filter level B	Range: 0~9 Initial value: 5		Word R/W
K7~K9	Reserved			
K10	Zero point calibration voltage return value	Return the present sensor input voltage after calibrating the zero point	CH1	Dword R
K12	Gain calibration digital value/gain calibration voltage return value	As weight input value for gain calibration. As return relative voltage for non-calibration		Dword R/W
K14	CH1 min scale division	Range: 1,2,5,10,20,50		Word R/W
K15	CH1 max range	Range: <1000000		Dword R/W
K17	Reserved			
K20	Zero calibration voltage return value	Return the present sensor input voltage after calibrating the zero point	CH2	Dword R
K22	Gain calibration value/gain calibration voltage return value	As weight input value for gain calibration. As return relative voltage for non-calibration		Dword R/W
K24	CH2 min scale division	Range: 1,2,5,10,20,50		Word R/W

K25	CH2 max range	Range: <1000000		Dword R/W
K27	Reserved			
K30	Zero calibration voltage return value	Return the present sensor input voltage after calibrating the zero point		Dword R
K32	Gain calibration value/gain calibration voltage return value	As weight input value for gain calibration. As return relative voltage for non-calibration	CH3	Dword R/W
K34	CH3 min scale division	Range: 1,2,5,10,20,50		Word R/W
K35	CH3 max range	Range: <1000000		Dword R/W
K37	Reserved			
K40	Zero calibration voltage return value	Return the present sensor input voltage after calibrating the zero point	CH4	Dword R
K42	Gain calibration value/gain calibration voltage return value	As weight input value for gain calibration. As return relative voltage for non-calibration		Dword R/W
K44	CH4 min scale division	Range: 1,2,5,10,20,50		Word R/W
K45	CH4 max range	Range: <1000000		Dword R/W
K47	Reserved			

Take module no.1 as an example:

Weight unit setting:

Write in weight through instruction TO. For example, the object weight is 1kg, write in 1 means the unit is kg, write in 1000 means the unit is g, write in 10000 means the unit is 0.1g. resolution=1kg/write in digital value.

Calibration:

Please calibrate the pressure sensor for the first time using.

Take module channel 1 as an example:

1. confirm whether the module and sensor work properly.

Judgment method:

First, monitor whether the overflow flag X10001 is OFF state. If it is ON, the sensor is not connected or the sensor is damaged.

Second, using the software to monitor whether ID10002 value fluctuates following sensor (fluctuation range is related to sensor range), and pressure value increased when increasing the load, if there are value but increase the load stress value decreases, that means (1) sensor installed opposite, please adjust the sensor position or exchange +/- of sensor output signal; (2) The incoming voltage signal has been overflow, reducing the load appropriately.

2. Make the sensor no load, after the stable flag X10000 is ON, set ON zero point calibration Y10002. X10002 ON means the zero point calibration is successful. If after few seconds, X10003 is ON, that means zero point calibration is failed.

3. Put the load whose weight is known on the scale, write the weight through TO instruction, after stable flag X10000 is ON, set ON gain calibration Y10003, X10002 ON means calibration is successful, shut off Y10003. If after few seconds, X10003 is ON, that means zero point calibration is failed.

4. Hereto, the calibration finished. The module will automatic adjust the result according to the idle load value and calibration value when weighing, and finally get the correct weight.

20-9. Module error info

Serious application error (related to main unit register address SD503 high 8 bits)

Error code			Meaning
Binary	Hex	Decimal	
0000 0001	0x01	1	Not connect 24V
0000 0010	0x02	2	Not finish the setting in 5s
0000 0011	0x03	3	Module model is different
0000 0011	0x04	4	Communicate with PLC error

The error code using method: write in module no. in SD500, if it needs to check module no.1 error code, please write in 10000.

20-10. Instruction FROM and TO

Write instruction TO

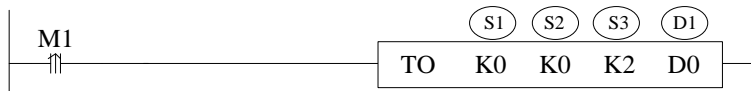

Function: write the PLC register data to module specified address, the unit is word.

Operand:

S1: target module number. Operand: K, TD, CD, D, HD, FD.

S2: module first address. Operand: K, TD, CD, D, HD, FD.

S3: write in register quantity. Operand: K, TD, CD, D, HD, FD.

D1: write in data register first address in PLC. Operand: TD, CD, D, HD, FD.

Example: write the weight value to module no.1 channel 1

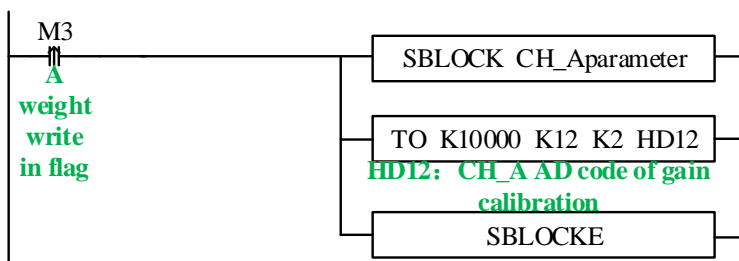

Read instruction FROM



Function: read the module data to PLC register, the unit is word.

Operand:

S1: target module number. Operand: K, TD, CD, D, HD, FD.

S2: module first address. Operand: K, TD, CD, D, HD, FD.

S3: read register quantity. Operand: K, TD, CD, D, HD, FD.

D1: PLC register first address. Operand: TD, CD, D, HD, FD.

For example: read all the parameters of module no.1

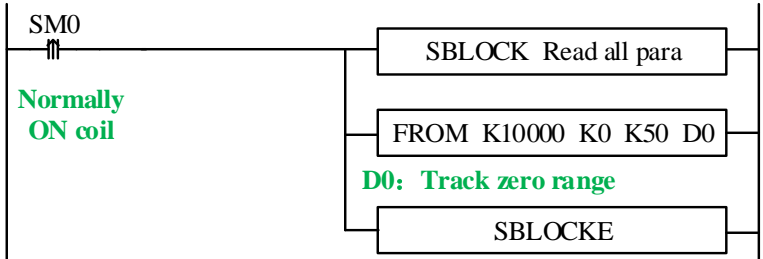

Note: FROM and TO instruction only can be added in sequence block, one program can support 100 sequence blocks. But only 8 sequence blocks can execute at the same time.

20-11. AD transformation diagram

The relationship between input analog voltage and converted digital value is shown as below:

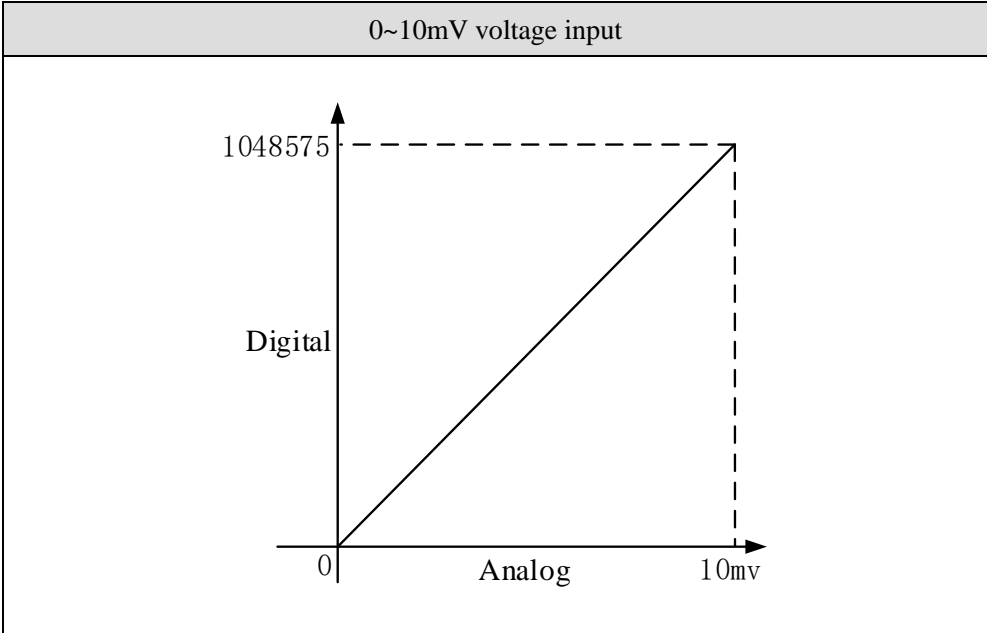

20-12. Application program

Take module 1 as an example:

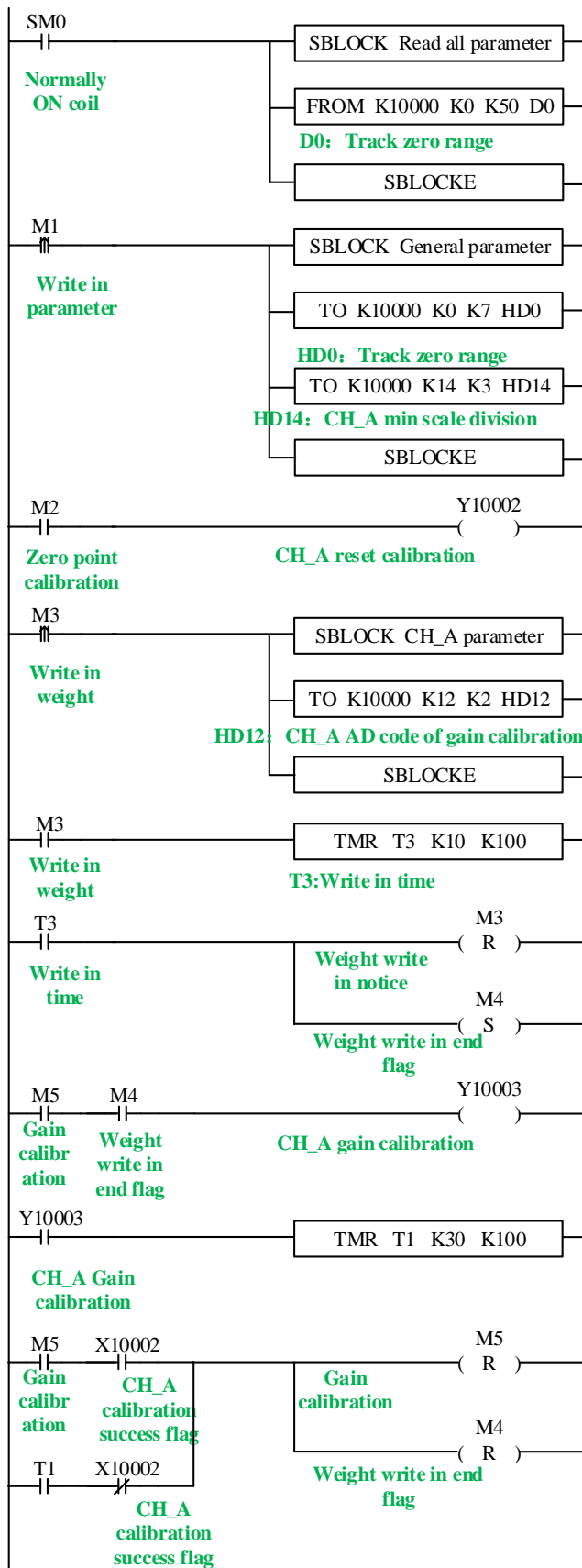

Explanation:

Read all the parameters and write in general parameters through FROM/TO instruction.

Set ON M1, write in all the parameters of channel 1.

Zero point calibration: set ON M2, if zero point calibration is successful, X10002 is set ON.

Gain calibration: first set ON M3, write the weight value HD12 to the module. After write in success flag M4 is ON, it starts to calibrate gain. Set ON M5 to start the calibration, the preset stable time is 3s. after the scale is stable, gain calibration success flag X10002 is ON or calibration time T1 reached, reset M4, M5, gain calibration is finished.

XINJE



WUXI XINJE ELECTRIC CO., LTD.

4th Floor, Building 7th, No.100 Dicui Rd,
Wuxi, China

Tel: 86-0510-85134139

Fax: 86-0510-85111290

www.xinje.com