

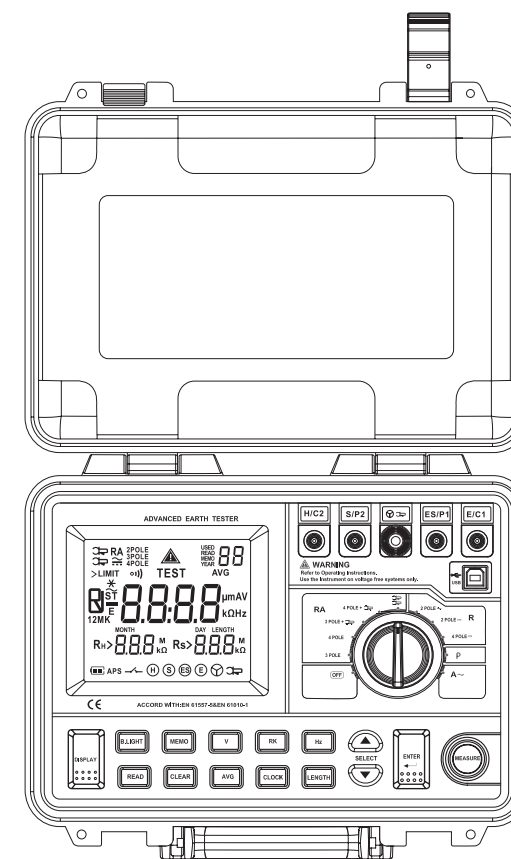

Y01-04-0074 A0





ADVANCED EARTH TESTER

USERS MANUAL

说明书尺寸：210*145mm

CONTENTS

Safety Instructions	1
Safety Symbol Descriptions	1
Points of Attention During Operation.....	3
Introduction	5
Checking Upon Receiving.....	7
Accessories	9
General Description	10
Product Introduction	10
Features	10
Names and Functions Of components	11
<i>Input terminals:</i>	11
<i>Operation panel:</i>	11
<i>Rotary switch</i>	13
<i>LCD</i>	14
Preparations before the test	15
Battery Installation/Replacement	15
Steps for replacing alkaline battery.....	15
Auto powering off	15
Setting date and time	16
Checking date and time	16
Connecting Testing Wires	16
Test Method	17
Introduction of methods for measuring earthing resistance	17
Checking before the Test	17
Measuring with 3-pole/4-pole method.....	17
<i>Start testing</i>	17

<i>Finishing a test</i>	19
<i>Review and delete the held data</i>	20
Selecting measuring method (3pole /4pole method)	21
<i>Start testing</i>	21
<i>Finishing a test</i>	22
<i>Review and delete the held data</i>	22
Test of Earthing-Resistance without Stake	23
<i>Start testing</i>	23
<i>Review/delete the held data</i>	24
AC Resistance Test.....	25
<i>Start testing</i>	25
' <i>DISPLAY</i> ' button for switching display (2 pole R~).....	25
DC Resistance Test.....	26
<i>Start testing</i>	26
' <i>DISPLAY</i> ' button for switching display (2 pole R ).....	26
' <i>DISPLAY</i> ' button for switching display (4 pole R ).....	26
Soil Resistivity Test.....	27
<i>Start testing</i>	27
' <i>DISPLAY</i> ' button for switching display (soil resistivity ρ).....	27
Test-wire resistance (R_K) measurement	29
Interference voltage/frequency test.....	30
Interference-Current Test	30
Saving Test Data	31
Reviewing Saved Data	32
Deleting Saved Data	34
PC Communication	35
Operation System Requirement:.....	35
Functions of PC Software:	35
Installing PC Software:	35
Downloading Data to PC/Configuring the Tester	35

Specifications	36
General Specifications	36
Technical Specification	38
<i>RA 3pole method</i>	38
<i>RA 4 pole method</i>	39
<i>RA 3pole (METER A /METER B)</i>	40
<i>RA 4pole (METER A/METER B)</i>	41
<i>Test of earthing-resistance without stake (METER A/METER B)</i>	42
<i>Soil resistivity test ρ</i>	42
<i>2pole R~</i>	43
<i>2pole R (METER A/METER B)</i>	43
<i>4pole R (METER A/METER B)</i>	44
<i>Compensation for Rk test-wire resistance (2-pole method)</i>	44
<i>Interfering voltage/current/frequency</i>	45
Maintenance and Repair.....	45
Table of trouble shooting	46
Cleaning	46
Disposal.....	46
Appendix table: Soil resistivity.....	47

Safety Instructions



Danger





The design of this instrument meets IEC61010 requirement, and tests in all aspects have been performed before packaging and shipment. Nevertheless, improper handling during operating may still cause damages to the tester and accidents in which physical injury or even death might occur. Please read this manual carefully before usage. Our company is not liable for any physical injury or accident that is caused by reasons other than flaws of the testing instrument itself.

Safety Symbol Descriptions

Safety Instructions

	Important information which the user shall read before use.
	Indication of possible dangerous voltage on the terminal.
	Indicating that this is an equipment with enhanced insulation
	DC Signal
	AC Signal

Warning Information

 Danger	Indicating that improper operation will cause accidents in which extremely serious injury or even death might occur
 Warning	Indicating that improper operation will cause accidents in which serious injury or even death might occur
 Note	Indicating that improper operations will cause physical injury to the operator, or damage to the tester.
 Tips	Operation suggestions or tips

Descriptions for other symbols

	Prohibited operation
	Quick reference

Definition of the Precision Symbols

dgt. (resolution)	The smallest unit of displaying for digital tester
rdg. (reading or displayed value)	Current reading of tester

Points of Attention During Operation

In order to ensure operation safety and operate with the optimal performance, please observe the following points of attention.

Initial checking

For first-time operation, please check the tester to ensure there is no damage occurred during storage and shipment, no any abnormal function with the tester. Before operating, please make sure the insulation of testing clamps, the cables are flawless and no conducting part is exposed. Otherwise, using the meter will cause electrical damage and injury.

Working environment

Ambient temperature and humidity: 0 ~40 °C (32 ~ 104 °F) < 80% RH (without condensation)

Range of temperature and humidity for guaranteed precision:

Earthing resistance measurements: 0~28 °C (32~82 °F) < 80% RH (without condensation)

Voltage measurements: 23±5 °C (73±9°F) < 80% RH (without condensation)

Operation

In order to avoid malfunctions and accidents, please do not subject the meter to the following situations:

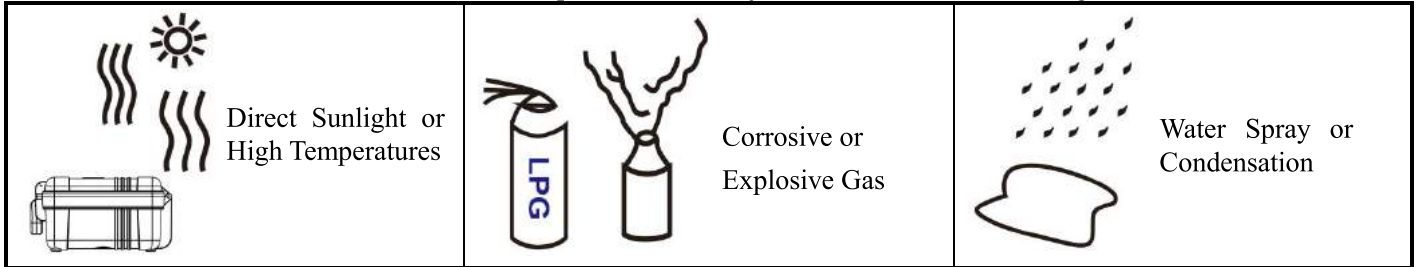

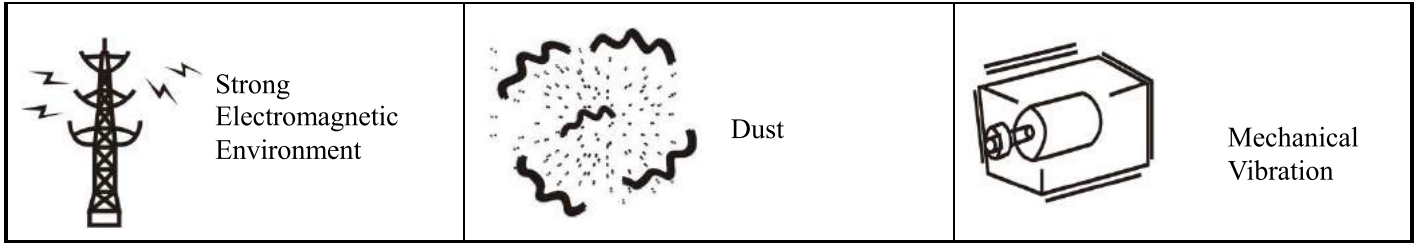

Danger

Please observe the following instructions to avoid electrical shocking and short-circuiting.

1. Before connecting or disconnecting a tester clamp, please turn power off and make sure the clamp is detached from the object being measured .
2. Please do not perform any measurement when opening the battery lid.
3. Please do not take out the internal components out of the case.
4. Please do not use the tester under environment with inflammable or explosive gas or with a lot of dust. (otherwise explosion might occur)
5. Please do not put the tester at a place where it is unstable. (In case the meter falls off, it might cause electrical malfunctions and injuries.)
6. Voltage will be generated by this meter during measurements, therefore, please take insulation measures according to industrial safety regulations in order to avoid electrical shock and injuries.
7. Before usage, please remind relevant persons nearby to take protective measures.



Note

1. Operation range of temperatures for this meter is 0 to 40 °C (32 to 104 °F).
2. During handling, transportation and operation, mechanical vibrations, especially vibrations during accident of falling off, shall be prevented, so that meter damages are avoided.
3. In case the protecting function of the meter fails to work, please contact the supplier for service, or make distinct marking to prevent it being used by other persons.

4. Only professional service technicians are authorized to calibrate and repair the meter.
5. The meter shall not be altered in any way, and it can only be taken apart and repaired by the service engineers of our company. Otherwise, it might cause fire, electrical shock and physical injuries.
6. When the meter is not in use, please close the cover.
7. Please turn off power after use.
8. To avoid damaging the meter, please do not insert other devices into the USB socket.
9. Do not replace the testing wire or clamp by your own, otherwise you shall be responsible for any problem it may cause.



Tips





1. The standby status in this manual is referred to the situation under which no measurement is being performed and no parameter adjustment is going on.
2. In case ambient temperature changes abruptly in great number of degrees, it might cause condensation and incorrect measurements.
3. Before measuring, please place the meter under the new test environment for a period of time.

Introduction

Thanks for purchasing the advanced earthing resistance tester designed and manufactured by our company. In order to ensure the proper use of the tester, please read this manual carefully before operating and keep it at a place where it can be easily found.

With the latest technology in a small-sized, robust and easy-to-use instrument, this series of earthing resistance tester is mainly used to test the earthing resistance of transformer, lightning-proof system, high-voltage power tower and telecommunication equipments, etc., providing a perfect solution for earthing-resistance test.

There are three models of this series, including Meter A, Meter B and Meter C, which can meet various requirements of different customers. The features are summarized in the following table.

Test mode	Functions	Meter A	Meter B	Meter C
3 pole & 4 pole earthing-resistance test	Test voltage: AC20V/48V	√	√	√
	Test frequency : 94Hz/105Hz/111Hz/128Hz/AFC	√	√	94Hz/128Hz
	Earthing-resistance range	0.02Ω~300KΩ	0.1Ω~30KΩ	0.1Ω~20KΩ
Selective mode (3 pole +  / 4 pole + )	Test voltage: AC20V/48V	√	√	
	Test frequency : 94Hz/105Hz/111Hz/128Hz/AFC	√	√	
	Earthing-resistance range	0.02Ω~20KΩ	0.1Ω~10KΩ	
Non-auxiliary-polar mode ()	Test voltage: AC48V	√	√	
	Test frequency : 94Hz/105Hz/111Hz/128Hz/AFC	√	√	
	Earthing-resistance range	0.02Ω~150Ω	0.1Ω~150Ω	
2 pole R~	Test voltage: AC20V	√	√	√
	Test frequency : 94Hz/105Hz/111Hz/128Hz/AFC	√	√	94Hz/128Hz
	Earthing-resistance range	0.02Ω~300KΩ	0.1Ω~30KΩ	0.1Ω~20KΩ
2 pole /4pole R 	Test voltage: DC20V	√	√	
	Earthing-resistance range	0.02Ω~3KΩ	0.1Ω~3KΩ	
Interfering voltage /current/frequency	Interfering voltage 1~50V DC/AC	√	√	√
	Interfering frequency 16Hz~400Hz	√	√	√
	Interfering current 20mA~2A	√	√	
Soil resistivity ρ	Test voltage: AC20V/48V	√	√	√
	Test frequency : 94Hz/105Hz/111Hz/128Hz/AFC	√	√	94Hz/128Hz
	Range: 0.02Ω·m~1000KΩ·m	√	√	√

Test mode	Functions	Meter A	Meter B	Meter C
RK(wire compensation)	Test voltage: AC20V/48V	√	√	√
	Test frequency : 94Hz/105Hz/111Hz/128Hz/AFC	√	√	94Hz/128Hz
	Range:	0.02~30Ω	0.1~30Ω	0.1~30Ω
	Test current	≦ 250mA	≦ 100mA	≦ 100mA
	Data storage	√	√	√
	USB communication	√	√	√

Checking Upon Receiving

Upon receiving, please firstly carefully check the tester. Please contact your supplier in case there is any obvious damage or any malfunction during the transaction.

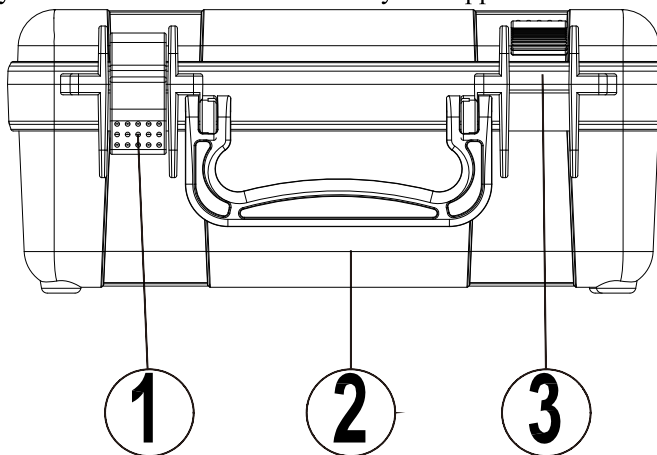

Fig. 1

To open the case

- 1、 Use your fingers to pull lock buckle outward.
- 2、 Lift lock buckle upward so as to release two buckles, and open the outer case.

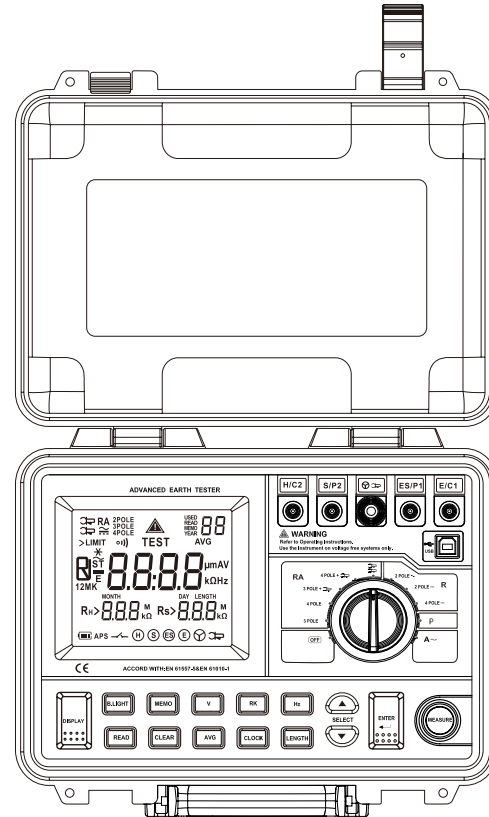
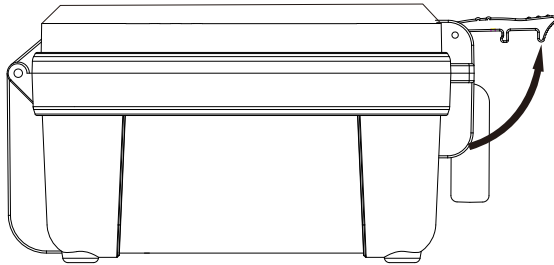
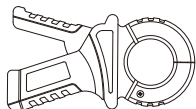
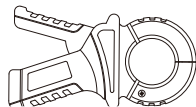

Fig.2

Accessories



Current Transformer
 ϕ 51mm



Voltage Transformer
 ϕ 51mm



Current clamp cable

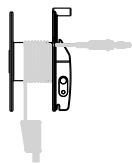

Test wire \times 4

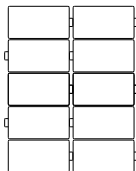

Alkaline battery \times 10



Voltage clamp cable

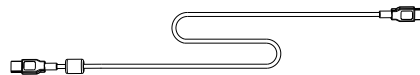

USB cable

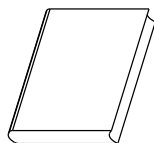

User manual

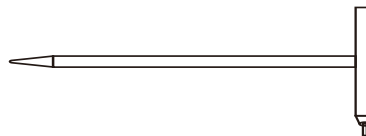

Prob

General Description

Product Introduction

This series advanced earthing-resistance testers integrated with multiple measuring methods, can be used for checking earthing-resistance of transformer, anti-lightning system, high-voltage power tower, and communication equipments, and its automatic frequency control (AFC) function can bring interference to an absolute minimum.

Main functions:

Basic function	Application
Earthing-resistance test	For testing the earthing-resistance of electrical equipments
Interference-voltage test	For testing the interference voltage of external circuits
Interference-current test	For testing the interference-current of external circuits
Soil resistivity test	For testing the average soil resistivity
AC resistance test	For testing resistance with 2-pole AC voltage
DC resistance test	For testing resistance with positive/reversed 2-pole DC voltage
Save	For saving test data
PC Communication	For transferring data to PC for analysis

Features

Optional testing voltage	20 V/48 V
Optional testing frequency	94Hz、105Hz 、111Hz 、128Hz 、 AFC
Test mode	Multiple optional test modes
Data storage	100 test data can be stored, which can be checked on the meter or uploaded to PC software.
Display	Digital/analog dual display; LCD with backlight.
PC Communication	Uploading the stored data to PC software through USB interface for analysis.
Robust and Durable	With a compact structure, the tester is robust, durable and portable.

Names and Functions Of components

Input terminals:

- ① H/C2 Socket
- ② S/P2 Socket
- ③ current clamp Socket
- ④ ES/P1 Socket
- ⑤ E/C1 Socket
- ⑥ USB Socket

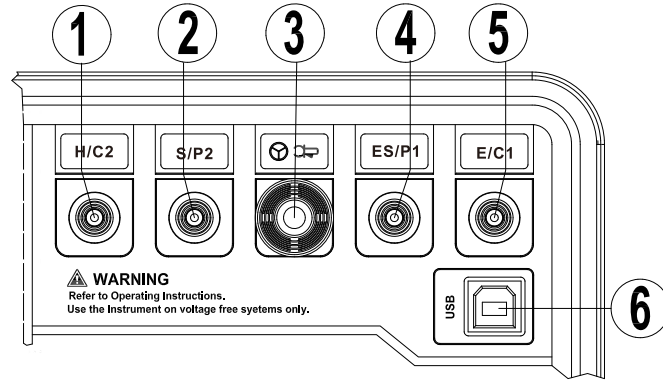

Operation panel

- ① **DISPLAY:** To change displayed item; when testing resistance, press it to switch between resistance and current display; when data is hold, press it to switch among: Fst, Re, R \sim , R $\overline{\text{---}}$, R1, R2, Rk, ρ , Fm, Ust, Um, Ist, and I \sim .
- ② **B.LIGHT:** To turn on/off LCD backlight which will be automatically turned off in 30 seconds; press the button during powering-on to cancel auto power-off function.
- ③ **MEMO:** To save measured data to internal non-volatile memory
- ④ **V:** To change testing voltage
- ⑤ **RK:** To start the resistance-compensation function of the test wire
- ⑥ **Hz:** To change testing frequency
- ⑦ **Δ :** To change the set value of testing voltage/frequency/date/time
- ⑧ **ENTER:** To confirm: the set value can be stored

⑨ MEASURE: To start or stop resistance test

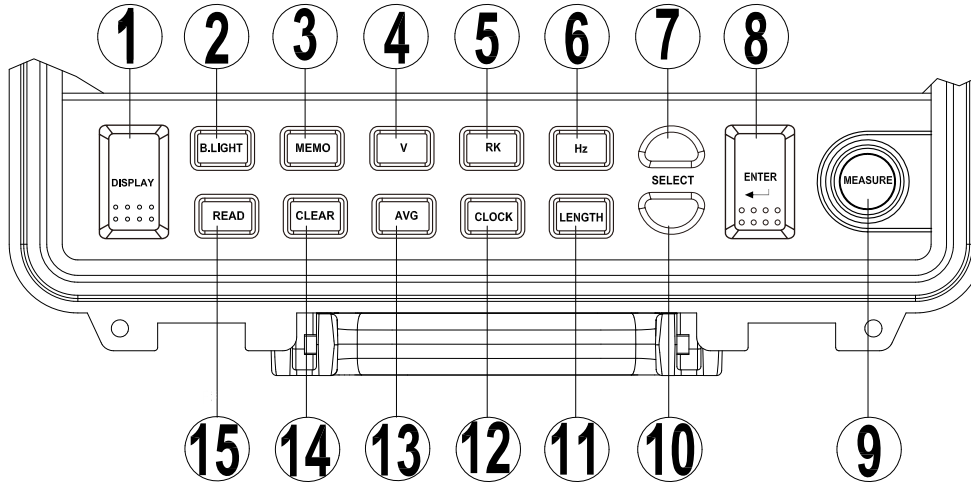

⑩ ▽: To change the set value of testing voltage/frequency/date/time

⑪ LENGTH: To set distance between test points during resistivity measurement

⑫ CLOCK: 1: To display date and time; 2: To switch input-cursor position when changing date/time





⑬ AVG: To start averaging function: measured resistance/current value can be processed in a smooth way

⑭ CLEAR: To clear data from internal non-volatile memory

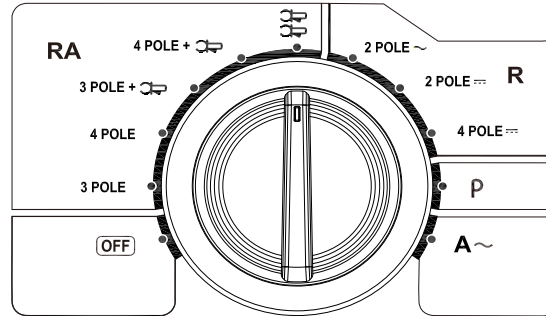
⑮ READ: Read data from internal non-volatile memory

Rotary switch



Rotary switch	Functions	Rotary switch	Functions
OFF	To turn off power	2POLE R ~	To test AC resistance with 2 POLE method
RA 3POLE	To test earthing-resistance with 3POLE method	2POLE R ≡	To test DC resistance with 2 POLE method
RA 4POLE	To test earthing-resistance with 4POLE method	4POLE R ≡	To test DC resistance with 4POLE method
RA 3POLE 	To test earthing-resistance with 3POLE method with current transformer	Soil resistivity 	To test soil resistivity with 4-pole method
RA 4POLE 	To test earthing-resistance with 4 POLE method with current transformer	Interfering current 	To measure AC interfering current with current transformer
RA 	To measure earthing resistance with current transformer and voltage transformer		

LCD

LCD symbol	Description		
R_E	Earthing resistance		
R_H	Auxiliary earthing resistance		
R_S	Probe resistance		
U_{ST}	Interfering voltage		
F_{ST}	Frequency of interference-voltage		
R_K	Compensation resistance		
F_M	Testing frequency		
U_M 20V/48V	Testing voltage		
R_1/R_2	Resistor with direction		
R_{\sim}	AC resistance		
APS	Auto powering off		
AFC	Automatic frequency		
TEST	A test is being performed		
LIMIT	Limit value	READ	Reading data
>LIMIT	The limit value is exceeded	MEMO	Storing data number
	Plug identification symbol	USED	There is data stored
	Alarming indicator for limit-value exceeding	LENGTH	Testing length between resistivity testing point
AVG	averaged-value measurement		DC symbol
	Measurement is interfered or unstable		AC symbol
	Battery capacity indicator		Negative symbol
			Warning symbol

Preparations before the test

Battery Installation/Replacement

- 1) In order to avoid electrical damages, please turn off power and disconnect test wires from the meter before replacing batteries.
- 2) Please do not use an old battery in combination with a new one, and do not use batteries of different models.
- 3) Pay attention to battery polarity during installation so as to avoid meter damages or unnecessary injuries
- 4) Please do not short-circuit or take apart used batteries in order to avoid explosion or environmental pollution.
- 5) Please properly dispose used batteries according to the requirements of local laws and regulations.
- 6) Replace the battery if there is an indication that the battery is short of power.
- 7) Only designated batteries may be used.
- 8) In order to avoid corrosion caused by battery leakage, please take out batteries when the meter is not to be used for a long period of time.

Steps for replacing alkaline battery

- 1) Turn power off and disconnect all test wires.
- 2) Loosen screws on the back and take off battery cover.
- 3) Place alkaline batteries in battery case.
- 4) Switch the battery selection switch to alkaline battery.
- 5) Put back battery-pack cover and tighten the screws.

Auto powering off

- 1) Rotate the “Rotary switch” from OFF position to other test position, and data will be shown on screen after 1 second and the tester will enter Sleep mode; upon powering-on, the parameters which were set before powering-off last time will be automatically loaded.
- 2) If there is no operation within 2 minutes, the tester will be automatically turned off; before it is turned off, APS symbol will flash for 10 seconds. During charging, auto powering-off function will be invalid. Press and hold “B.LIGHT” button during powering-on to cancel the auto powering-off function.
- 3) After tester is automatically power off, you can press any button to activate it from sleep mode.
- 4) If the battery power is at a low level, please replace battery or charge it in time; if you continue using the meter after

“LobAt” is displayed, the meter will be automatically turned off.

- 5) Rotate “Rotary switch” to OFF position, the screen display will be turned off and power is off.

Setting date and time

- 1) In Standby Status, Press ‘CLOCK’ to display “year/month/day/hour/minute”
- 2) Press “CLOCK” > 1s, and screen will flash, and value can be modified.
- 3) Press “CLOCK” to change flash position
- 4) Press Δ/∇ to change value at flash position
- 5) Press “Enter” to save and return

Note 1: Upon pressing the Enter button, the clock starts to run from 0 seconds.

Note 2: Date and time can be adjusted through the communication software which is installed on a PC

Checking date and time

- 1) Standby Status
- 2) Press “CLOCK” to display year/month/day/hour/minute
- 3) Press “ENTER” or “CLOCK” to return

Connecting Testing Wires

- 1) Insert test-wire tip all the way into clip/test clamp
- 2) Properly connect the other end of test-wire
- 3) Properly connect clip/test clamp to test object
- 4) Check test probe for contact reliability



Danger

- a) Before connecting/disconnecting a test clamp, please make sure that the clamp is detached from the object being measured and power is turned off in order to avoid electrical damages.
- b) In order to avoid electrical damages, please do not use the tester when the housing is damaged.
- c) This instrument can only be used in systems without voltage.

Test Method

Introduction of methods for measuring earthing resistance

With 3-pole/4-pole earthing-resistance testing function, the earthing resistance of single-point earthing system and soil resistivity can be measured; with 3 pole/4 pole method and current clamp, resistance of a single branch circuit in an inter-connecting network can be tested without disconnecting the earthing system; with current clamp and voltage clamp, resistance in an inter-connecting network can be tested without disconnecting the earthing system.

Checking before the Test



Warning

- a) Check the bottom shell of the tester, top cover, testing wires, alligator clips, clamp head, and socket for damages; please do not use the meter in case any damage is found.
- b) Please make sure that the socket is clean and dry. Use a piece of dry cloth to wipe off any water to avoid test error.
- c) Before measurement, please make sure that the test object is not live.
- d) Dangerous voltages might be generated at the test terminals during earthing-resistance measurements, and therefore please do not touch the terminals/test probes/object being tested in order to avoid electric shock.
- e) In order to avoid damaging the equipment that is to be tested, please check the test voltage before measurement.

Measuring with 3-pole/4-pole method

Start testing

- 1) Turn rotary switch to RA 3 POLE/RA 4 POLE
- 2) Properly connect test electrode to test object
- 3) Press V/Hz button then press Δ / ∇ to set voltage & frequency. Press ENTER to return
- 4) Press MEASURE >1s to start test, TEST symbol & MEASURE backlight flash
- 5) Resistance value is displayed; if unstable, press AVG to show average
- 6) Press MEASURE to stop or wait 20s for auto-stop, read result

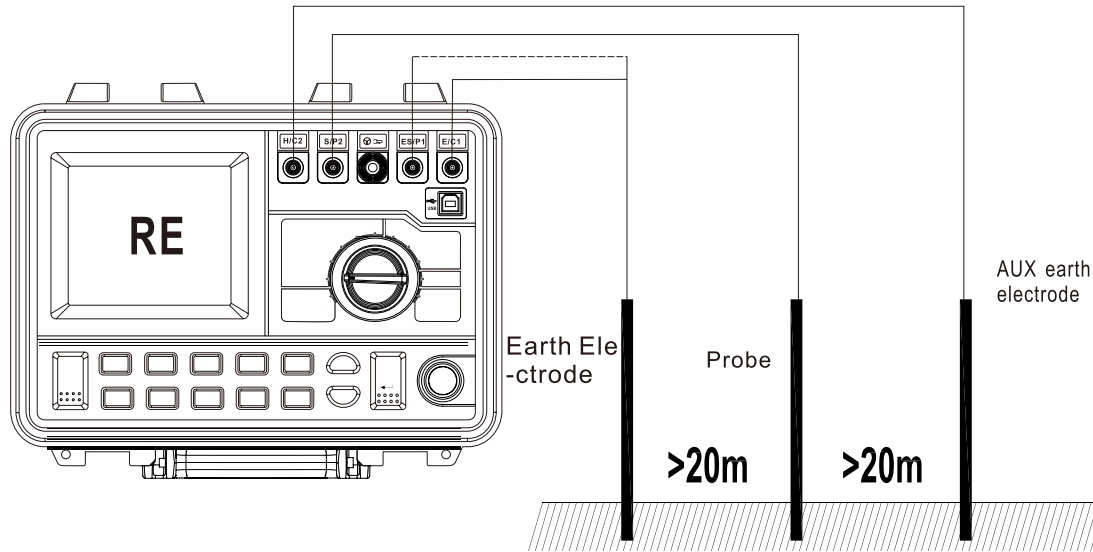

Tips







- If E ES S H V OFF is flashing, it indicates problematic test-wire connection; please check and correct connections.
- If „>“ and LIMIT symbol start to flash, it indicates the measured value is too large and exceeds the measuring range.
- If readings are not stable, you can use the measurement average function as follows: press AVG button to activate/deactivate AVERAGE function; after AVG symbol is displayed, the readings will be updated every 4 seconds; however, the readings will still be updated every 1 second under the following situations: within the first 15 seconds after the start of measurement; within the first 5-10 seconds after the measuring range is changed.



Note

- a) Do not let the test clamps come into contact with each other, and do not place other objects on the clamps so that measuring errors can be avoided.
- b) Before use, please make sure the test clamps are clean; a smeared clamp will adversely affect the measurement. Earthing resistance is not stable. For certain objects, test values from repeated measurement might not be consistent.
- c) The capacitance and resistance of the object being tested might be low initially, and then increase gradually, and finally be stabilized.
- d) Keep test wire at an appropriate distance from each other.
- e) A distance above 20 m should be kept among probe, auxiliary earthing-electrode, and earthing pin, and the three should be aligned; generally the above settings can meet normal requirements.

Earthing-resistance measurement cannot be started under the following circumstances:

- a) When U_{st} voltage is greater than 24 V (for earthing resistance R_E or AC resistance $R \sim$ measurement) or 3 V (for DC resistance R_{RE} measurement).
- b) When       symbol or its corresponding indicator LED is flashing.
- c) When battery voltage is too low and LObAt symbol is displayed.
- d) When an error message is displayed.

Finishing a test

- 1) RESISTANCE mode
- 2) Press MEASURE or wait for auto-stop, held last result
- 3) TEST symbol & key backlight stop flash



Note

- 1: Before stopping measuring, do not disconnect the test clamp from the object being tested.
- 2: When voltage drops below 3 V, backlight for TEST, flashing symbols and MEASURE button will be turned off.
- 3: In case battery power is insufficient during measurement, the tester will automatically stop the measurement and LObAt symbol will be displayed.

Review and delete the held data

After earthing resistance measurement is finished, the following values will be displayed on screen.

1. Earthing resistance: R_E
2. Auxiliary earthing resistance: R_H
3. Probe resistance: R_S
4. Interfering voltage: U_{ST}
5. Interfering frequency: F_{ST}
6. Compensation resistance: R_K
7. Testing frequency: F_M

“DISPLAY” button for switching display (3 pole method)

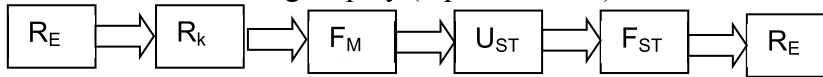

“DISPLAY” button for switching display (4 pole method)

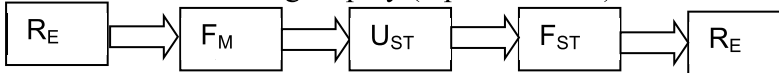

Note

The held data will be cleared after powering off, therefore please use SAVE function to save data.



Delete the held data

Push and hold CLEAR button longer than 1 second to clear the held data.

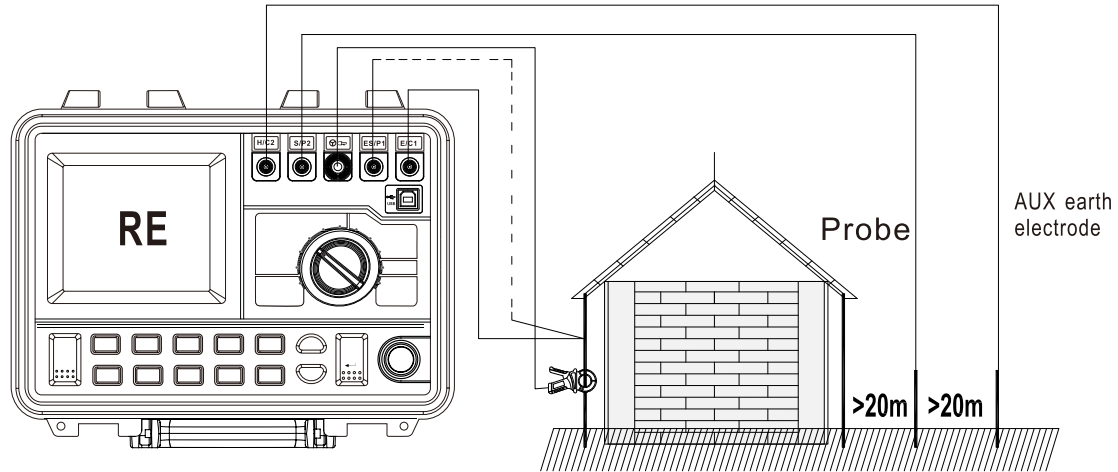
Selecting measuring method (3pole /4pole method)



Start testing

- 1) Turn switch to 3pole  or 4pole 
- 2) Properly connect test electrode to test object
- 3) Press V/Hz, then Δ / ∇ To set voltage & frequency, press ENTER to return.
- 4) Press MEASURE > 1s to start test. TEST symbol & MEASURE backlight flash.
- 5) Resistance value displayed. If unstable, press AVG to display average
- 6) Press MEASURE to stop or wait 20s for auto-stop. Read result.

Finishing a test

- 1) RESISTANCE mode ac
- 2) Press MEASURE or wait for auto-stop. Hold last result
- 3) TEST symbol& key bklight stop flash



Note

1. Before stopping measuring, do not disconnect the test clamp from the object being tested.
2. When voltage drops below 3 V, backlight for TEST, flashing symbols and MEASURE button will be turned off.
3. In case battery power is insufficient during measurement, the tester will automatically stop the measurement and LObAt symbol will be displayed.

Review and delete the held data

After earthing resistance measurement is finished, the following values will be displayed on screen:

1. Earthing resistance: R_E
2. Auxiliary earthing resistance: R_H
3. Probe resistance: R_S
4. Interfering voltage: U_{ST}
5. Interfering frequency: F_{ST}
6. Compensation resistance: R_K
7. Testing frequency: F_M

“DISPLAY” button for switching display 3 pole  method

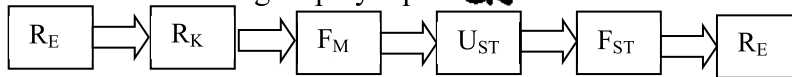

“DISPLAY” button for switching display 4-pole  method

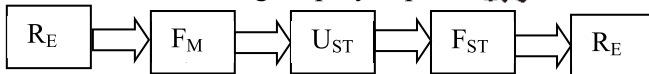



Note:

The held data will be cleared after powering off, therefore please use the MEMO function to save data.

Delete the held data

Push CLEAR button and hold it longer than 1 second to clear the held data.

Test of Earthing-Resistance without Stake

When testing single earthing-resistor in an parallel earthing-connecting system, if the parallel earthing resistance of $R_1 \dots R_n$ is much lower than the earthing resistor R_x that is being tested, then $R_x \approx U/I$.

Start testing

- 1) Turn switch to “3pole +  ”
- 2) Connect electrode to object
- 3) Press V/Hz, then Δ/∇ to set voltage & frequency. Press ENTER to return
- 4) Press MEASURE>1s to start test. TEST symbol & MEASURE backlight flash
- 5) Resistance value is shown. If unstable, press AVG to show average
- 6) Press MEASURE to stop or wait 20s for auto-stop. Read result

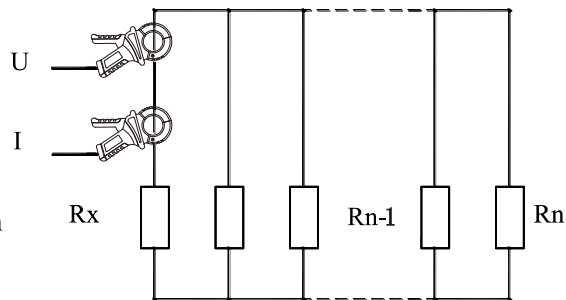

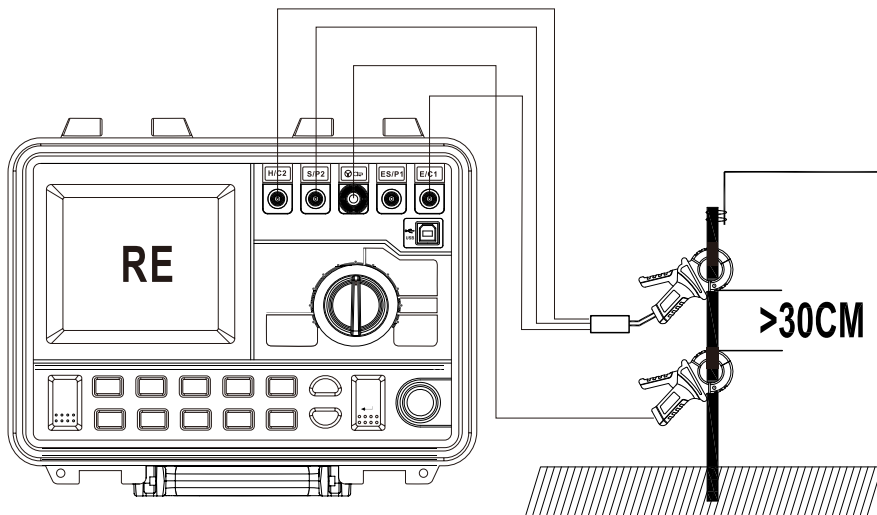

Note: During the test without stake, the distance between two clamp heads should be larger than 30 cm.
Review/delete the held data

‘DISPLAY’ button for switching display ()



Delete the held data

Push CLEAR button and hold it for longer than 1 second to clear the held data.

AC Resistance Test

Measuring resistance with AC method; when testing resistance is lower, it can be considered to use R_k to compensate the test wire.

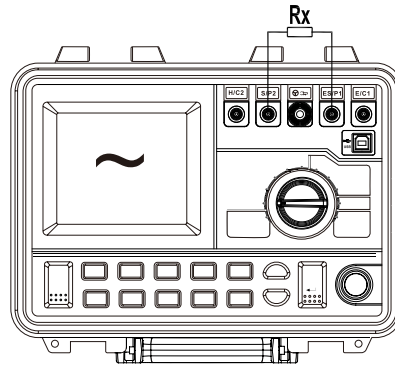

Start testing

- 1) Turn switch to 2 pole $R\sim$
- 2) Connect electrode to object
- 3) Press V/Hz then Δ/∇ to set VOLTAGE & FREQ. Press ENTER to return
- 4) Press MEASURE>IS to start test. TEST symbol & MEASURE bklight flash
- 5) Resistance value is shown. If unstable, press AVG to show average
- 6) Press MEASURE to stop or wait 20 s for AUTO-STOP. Read result

“DISPLAY” button for switching display (2 pole $R\sim$)

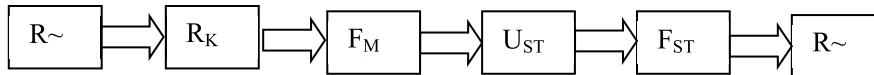

DC Resistance Test

Test resistance with DC voltage and polarity reversing method as per EN61557-5: to attain the highest accuracy, you can test with DC 4 pole method; if necessary, you can use R_K function to compensate the test wire.

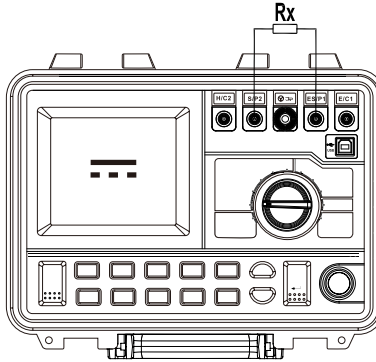

Start testing

- 1) Turn switch to 2-pole $R_{\text{---}}$ /4-pole $R_{\text{---}}$
- 2) Connect electrode to object
- 3) Press MEASURE>1s to test. TEST symbol & MEASURE bklight flash
- 4) Resistance value is shown. If unstable, press AVG to display average.
- 5) Press MEASURE to stop or wait 20 s for auto-stop. Read result.

“DISPLAY” button for switching display (2 pole $R_{\text{---}}$)

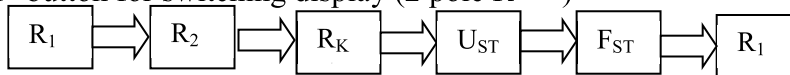

“DISPLAY” button for switching display (4 pole $R_{\text{---}}$)



Soil Resistivity Test

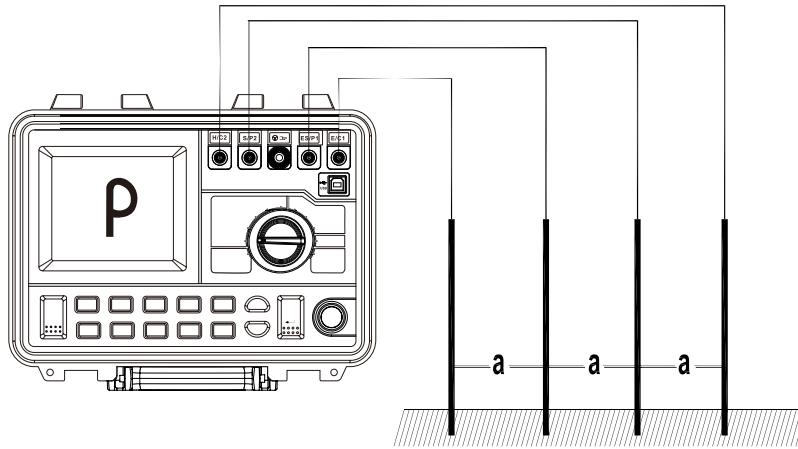

Start testing

- 1) Turn switch to ρ
- 2) Connect electrode to object
- 3) Press V/Hz/LENGTH, then Δ / ∇ to set Voltage/freq/length Press ENTER to return
- 4) Press MEASURE >IS to test. TEST symbol & MEASURE bklight flash
- 5) Resistance value is shown. If unstable, press AVG to show average
- 6) Press MEASURE to stop or wait 20 s for auto-stop. Read result

“DISPLAY” button for switching display (soil resistivity ρ)



Resistance R_E can be calculated from the displayed resistivity ρ

$$R_E = \rho / 2\pi \cdot a$$

ρ : the average soil resistivity $\Omega \cdot m$

R_E : the test resistance Ω

a : probe distance (2 m -30 m)

Deeper layer of soil can be measured by increasing “ a ”, and its uniformity can be tested. If “ a ” is changed for multiple times, a plot can be obtained, by which a proper earthing electrode can be determined; depending on the test depth, “ a ” is usually between 2 and 30 m. With this method, a plot as described in the following chart can be obtained.

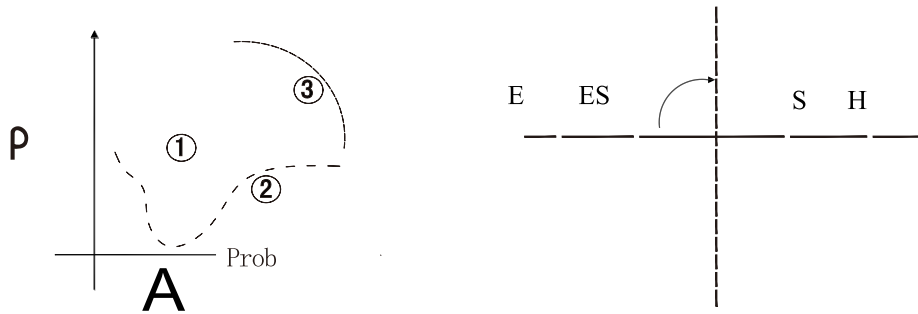

Plot 1: When depth is increased and ρ is not decreased: a bar-shaped conductor electrode is recommended.

Plot 2: When ρ is only decreased toward A point, increasing depth, which is larger than A, will not improve the measured value.

Plot 3: When ρ is only decreased downward, a deep-buried earthing electrode is recommended.

Note: underground metals and soil layer containing water will result in unreliable test results; hence a second test is suggested with earthing pin being rotated by 90° around its axis.

Test-wire resistance (R_k) measurement

When R_k function is used with 3 pole method /3 pole  /2 pole R_{\sim} /2pole R_{\sim} , error due to test-wire resistance can be eliminated with R_k compensation.

Measurement calculation: Re displayed value = Measured value – R_k .

- 1) Press R_k button. R_k flashes
- 2) Short-circuit corresponded wire according to graph
- 3) Press MEASURE to test. After about 20 s, auto-stop. Press ENTER to save R_k

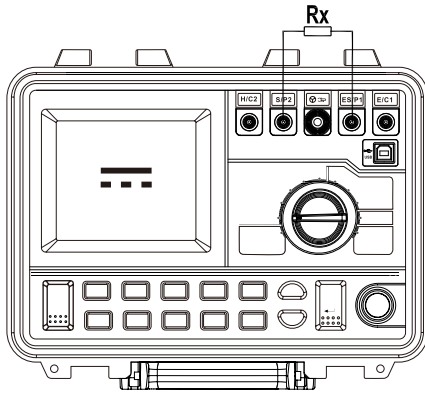

Test-wire compensation

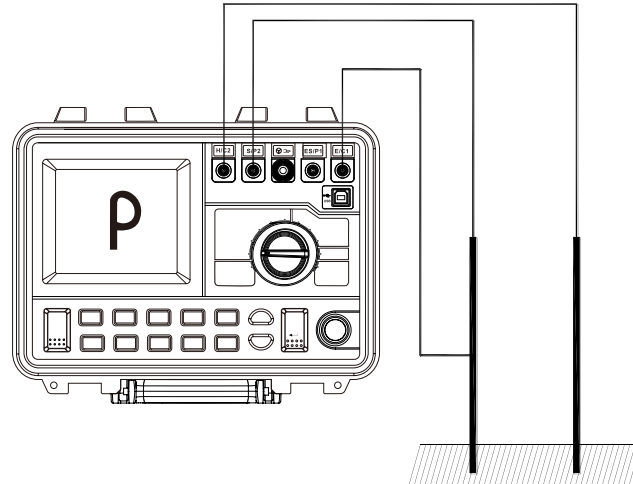

Earth electrode-wire compensation

Note: If the tester is restarted after powering-off, the pre-set R_k value is not saved.

Interference voltage/frequency test

Before testing earthing resistance, the tester automatically start this function with priority; only when interference voltage is greater than 1 V, the meter can display the measured interference voltage/frequency; if interference voltage is greater than 24 V during AC resistance test or 3 V during DC resistance test, earthing resistance test will be automatically prohibited. You can review the test value of interference frequency with DISPLAY button.

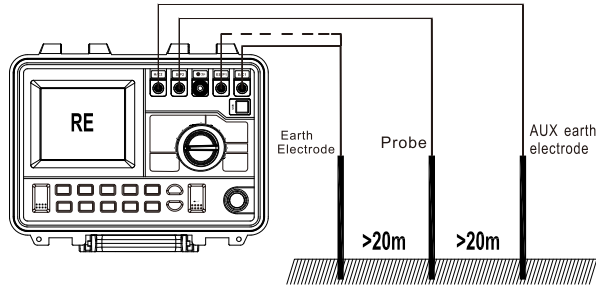

Interference voltage/frequency

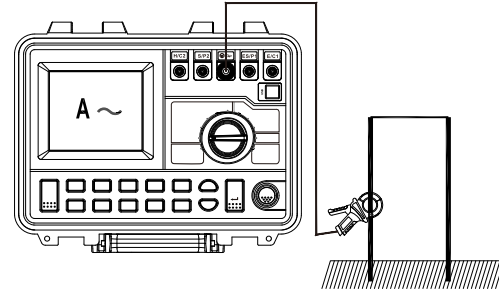

Interference current

Interference-Current Test

- 1) Turn switch to Interference current (A~)
- 2) Connect current clamp to object
- 3) Press MEASURE>IS to test. TEST symbol & MEASURE bklight flash
- 4) Resistance value is shown. If unstable, press AVG to show average
- 5) Press MEASURE to stop. Read result

‘DISPLAY’ button for switching display (interference current A~)

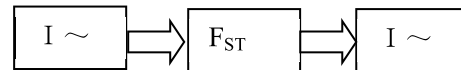

Saving Test Data

- 1) The tester can save test data, set parameters, time and date in the internal memory, and the saved data will not be lost after powering-off.
- 2) The saved data can be reviewed on the tester, and uploaded to PC via USB port.

Data Storage

Altogether 100 data can be saved with the number as: 00 – 99.

Operation procedures

- 1) Start test
- 2) Stop test
- 3) Set number
- 4) Press enter

Operation steps

- 1) Stop Test
- 2) Press “MEMO” button Data # flashes
- 3) Press \triangle/∇ button to select data#
- 4) Press ENTER to save



Tips

1. If USED symbol is displayed for the selected data number, the saved data will not be overwritten.
2. If MEMO button is pushed instead of ENTER button, data will not be saved and the system will directly return to the previous interface.
3. Compensated resistance value Rk cannot be saved.
4. Interference voltage/current/frequency cannot be saved.

Reviewing Saved Data

Operating steps:

- 1) Standby.
- 2) Press READ button. Data# & data flash
- 3) Press Δ/∇ button to select data #
- 4) Press DISPLAY button to show data
- 5) Press READ button to return



Tips

Note 1: Push READ button under STANDBY mode (MEMO No. symbol must be turned off)

Note 2: Push READ button, and “no dAt” will be displayed at the upper right corner if there is no data in the memory, and “no dAt” will automatically disappear after 1 second.

Part of the recorded data is not directly displayed on screen; to review data that is not displayed, you need to push DISPLAY button for switching

‘DISPLAY’ button for switching display (RA 3pole and RA 3pole )

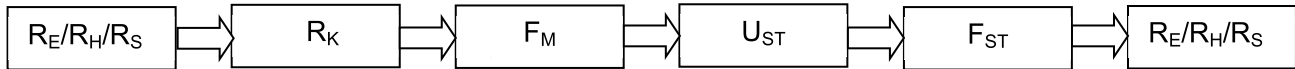

DISPLAY button for switching display (RA 4pole and RA 3pole )



DISPLAY button for switching display (RA )

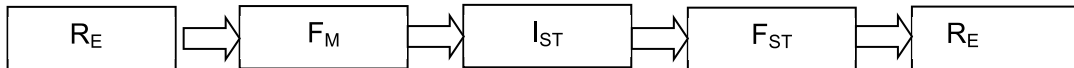

DISPLAY button for switching display (2pole R~)

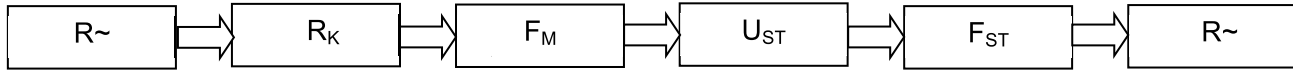

DISPLAY button for switching display (2pole R $\overline{\sim}$)

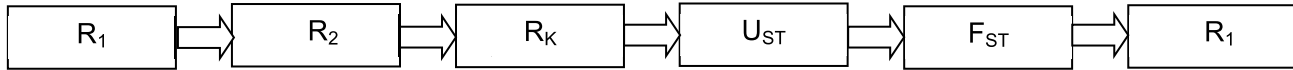

DISPLAY button for switching display (4pole R $\overline{\sim}$)

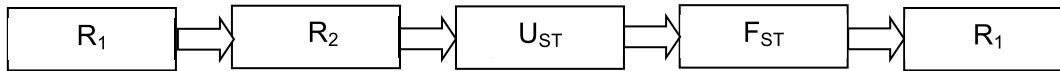

DISPLAY button for switching display (soil resistivity ρ)



DISPLAY button for switching display (interference current A~)

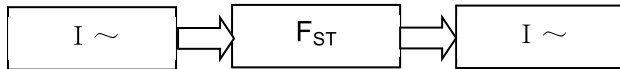

Deleting Saved Data

Delete specified data

- 1) Standby
- 2) Press READ button. READ No. lit up. Data # & data flash
- 3) Press \triangle/∇ button to select data# for delete
- 4) Press CLEAR button. “Clr” shown
- 5) Press ENTER button for deleting

Note: If “READ” button is pushed instead of “ENTER” button, data will not be deleted and the system will directly return to the previous interface.

Deleting all data

- 1) Standby
- 2) Press READ button. READ No. lit up. Data# & data flash
- 3) Press CLEAR button twice. “All Clr” shown
- 4) Press ENTER for deleting all

Note: If READ button is pushed instead of ENTER button, data will not be deleted and the system will directly return to the previous interface.

PC Communication

Operation System Requirement:

- 1) Operation system: WINDOWS XP(SP3) or Updated version
- 2) Hard-disk capacity: 100 MB available space
- 3) Interface: USB

Functions of PC Software:

- 1) To obtain saved data from the tester
- 2) Display obtained data and saving test data
- 3) Set tester parameters

Installing PC Software:

- 1) Double click on SETUP.EXE in the supplied software disk
- 2) Install software according to software instructions.

Downloading Data to PC/Configuring the Tester

When the test clamps are connected to the tester, please do not connect the tester with PC.

- 1) Use USB cable to connect the tester with PC.
- 2) Run the communication software on PC.

Note: During data transfer between PC and tester, do not unplug the USB cable so that transfer errors can be avoided.

Specifications

General Specifications

Table 1:

Ambient temperature and humidity for test	0~40°C, < 80% RH (without condensation)
Temperature for battery charging	10~40 °C , < 80% RH
Storage temperature and humidity	-10~50 °C , < 90% RH (without condensation)
Temperature & humidity for battery-pack storage	-20~30°C, < 80% RH (without condensation)
Altitude for storage	< 12000 m
Altitude for operation	< 2000 m
Clamp Diameter	φ 51mm
Display	LCD with backlight; Max. number: 9999
Overflow indication	> LIMIT
Underflow indication	-
Frequency for updating display	For earthing-resistance/leak-current: once per second (once in every four seconds if AVERAGE function is used)
	Detection of output voltage: twice per second
	Interference voltage: 4 time per second

Table 2:

Terminals	1) Resistance test:  2) USB, charger
Power supply	LR14 alkaline battery X 10; rated voltage:1.5v X 10
Max. power consumption	15 VA (using charger) 6 VA (using batteries or rechargeable battery pack)
Max. powering time	Alkaline battery: about 5 hours; battery pack: about 9 hours (with backlight turned off)
Max. input voltage	250 V AC (50~400 Hz)
Max. rated voltage to earth	300 Vrms (CAT III)
Insulation strength	6880 VAC: 15 seconds
Overload protection	250 VAC between terminals: 1 minute
Dimensions	260 (W)×125 (H)×280 (L) mm
Weight	Aprox. 2.5 kg
Applicable standards	1. Safety: EN61010-1:2001, EN61010-031:2002, Pollution degree 2; Measurement category III 300V; 2. EMC: EMC: EN61000-3-2:2000 IEC61326-1: 1997 A grade

Table 3: Main functions

Testing earthing resistance, soil resistivity, interference voltage/interference/current
Compensating test-wire resistance
Data saving function: recording (100 records), deleting a single record, deleting all records, uploading data to PC
Clock
AVERAGE function for test data
ALARM function for input terminals
Auto powering-off

Technical Specification
RA 3pole method

Testing voltage	AC 20/48V
Testing frequency	94Hz/105Hz/111Hz/128Hz /AFC(Meter A/ Meter B) 94Hz/128Hz (Meter C)
Short-circuit current	250mA(Meter A) 100mA(Meter B/Meter C)
Test duration	26s
Probe resistance R_s	<100k Ω
Auxiliary earth resistance R_h	<100k Ω
R_E resolution	0.001 Ω
R_E Measuring range	0.02 Ω ~300K Ω $\pm(5\%rdg+10d)$ (Meter A)
	0.1 Ω ~30K Ω $\pm(5\%rdg+10d)$ (Meter B)
	0.1 Ω ~20K Ω $\pm(5\%rdg+10d)$ (Meter C)
U_{ST}	<24V
F_{ST}	16~400Hz

Note 1: Range of temperature and humidity in which measuring precision is guaranteed: 0 - 28 °C, < 80% RH (without condensation)

Note 2: Response time < 15 seconds (Time needed for attaining the specified precision for the displayed value from the start of measurement with average function turned off).

RA 4 pole method

Testing voltage	AC 20/48V
Testing frequency	94Hz/105Hz/111Hz/128Hz /AFC(Meter A/ Meter B)
	94Hz/128Hz (Meter C)
Short-circuit current	250mA(Meter A)
	100mA(Meter B/Meter C)
Test duration	30s
Probe resistance Rs	<100kΩ
Auxiliary earth resistance Rh	<100kΩ
R _E resolution	0.001Ω
R _E Measuring range	0.02Ω~300KΩ ±(5%rdg+10d) (Meter A)
	0.1Ω~30KΩ ±(5%rdg+10d) (Meter B)
	0.1Ω~20KΩ ±(5%rdg+10d) (Meter C)
U _{ST}	<24V
F _{ST}	16~400Hz

Note 1: Range of temperature and humidity in which measuring precision is guaranteed: 0 - 28 °C, < 80% RH (without condensation)

Note 2: response time < 25 seconds (Time needed for attaining the specified precision for the displayed value from the start of measurement with AVERAGE function turned off).

RA 3pole (METER A /METER B)

Testing voltage	AC 20/48V
Testing frequency	94Hz/105Hz/111Hz/128Hz /AFC
Short-circuit current	250mA(Meter A)
	100mA(Meter B)
Test duration	26s
Probe resistance R_s	<100k Ω
Auxiliary earth resistance R_h	<100k Ω
R_E resolution	0.001 Ω
R_E Measuring range	0.02 Ω ~20K Ω $\pm(5\%rdg+10d)$ (Meter A)
	0.1 Ω ~10K Ω $\pm(5\%rdg+10d)$ (Meter B)
U_{ST}	<24V
F_{ST}	16~400Hz

Note 1: Range of temperature and humidity in which measuring precision is guaranteed: 0 ~ 28 °C, < 80% RH (without condensation)

Note 2: Response time < 25 seconds (Time needed for attaining the specified precision for the displayed value from the start of measurement with average function turned off).

Note 3: If current on current clamp is too low, measuring might be terminated.

RA 4pole (METER A/METER B)

Testing voltage	AC 20/48V
Testing frequency	94Hz/105Hz/111Hz/128Hz /AFC
Short-circuit current	250mA(Meter A)
	100mA(Meter B)
Test duration	26s
Probe resistance R_s	<100k Ω
Auxiliary earth resistance R_h	<100k Ω
R_E resolution	0.001 Ω
R_E Measuring range	0.02 Ω ~20K Ω $\pm(5\%rdg+10d)$ (Meter A)
	0.1 Ω ~10K Ω $\pm(5\%rdg+10d)$ (Meter B)
U_{ST}	<24V
F_{ST}	16~400Hz

Note 1: Range of temperature and humidity in which measuring precision is guaranteed: 0 - 28 °C, < 80% RH (without condensation)

Note 2: Response time < 25 seconds (Time needed for attaining the specified precision for the displayed value from the start of measurement with average function turned off).

Note 3: If current on current clamp is too low, measuring might be terminated.

Test of earthing-resistance without stake (METER A/METER B)

Testing voltage	AC 48V
Testing frequency	94Hz/105Hz/111Hz/128Hz /AFC
Short-circuit current	250mA(Meter A)
	100mA(Meter B)
Test duration	26s
R _E resolution	0.001Ω
R _E Measuring range	0.02~150Ω ±(10%rdg+10d)
	0.1~150Ω ±(10%rdg+10d)
U _{ST}	<24V
F _{ST}	16~400Hz

Note 1: Range of temperature and humidity in which measuring precision is guaranteed: 0 ~ 28 °C, < 80% RH (without condensation)

Note 2: Response time < 25 seconds (Time needed for attaining the specified precision for the displayed value from the start of measurement with average function turned off).

Note 3: If current on current clamp is too low, measuring might be terminated.



Soil resistivity test ρ

Testing voltage	AC 20/48V
Testing frequency	94Hz/105Hz/111Hz/128Hz /AFC(Meter A/ Meter B)
	94Hz/128Hz (Meter C)
Short-circuit current	250mA(Meter A)
	100mA(Meter B/ Meter C)
Test duration	26s
ρ resolution	0.001Ω·m
ρ Measuring range	0.02~1000KΩ·m ±(5%rdg+10d)

2pole R~

Testing voltage	A C 20V
Testing frequency	94Hz/105Hz/111Hz/128Hz /AFC(Meter A/ Meter B) 94Hz/128Hz (Meter C)
Short-circuit current	250mA(Meter A) 100mA(Meter B/ Meter C)
Test duration	26s
R~ resolution	0.001Ω
R~ Measuring range	0.02Ω~300KΩ ±(5%rdg+10d) (Meter A) 0.1Ω~30KΩ ±(5%rdg+10d) (Meter B) 0.1Ω~20KΩ ±(5%rdg+10d) (Meter C)
U _{ST}	<24V
F _{ST}	16~400Hz

2pole R (METER A/METER B)

Testing voltage	DC 20V
Short-circuit current	250mA(Meter A) 100mA(Meter B)
Test duration	26s
R  resolution	0.001Ω
R  Measuring range	0.02Ω~3KΩ ±(5%rdg+10d)(Meter A) 0.1Ω~3KΩ ±(5%rdg+10d)(Meter B)
U _{ST}	≤3V
F _{ST}	16~400Hz

4pole R_{res} (METER A/METER B)

Testing voltage	DC 20V
Short-circuit current	250mA(Meter A)
	100mA(Meter B)
Test duration	26s
R _{res} resolution	0.001Ω
R _{res} Measuring range	0.02Ω~3KΩ ±(5%rdg+10d)(Meter A)
	0.1Ω~3KΩ ±(5%rdg+10d)(Meter B)
U _{ST}	≤3V
F _{ST}	16~400Hz

Compensation for R_k test-wire resistance (2-pole method)

Testing voltage	AC 20/48V
Testing frequency	94Hz/105Hz/111Hz/128Hz /AFC(Meter A/ Meter B)
	94Hz/128Hz (Meter C)
Short-circuit current	250mA(Meter A)
	100mA(Meter B/ Meter C)
Test duration	26s
R resolution	0.001Ω
R Measuring range	0.02~30.00Ω ±(3%rdg+10d) (Meter A)
	0.1~30.00Ω ±(3%rdg+10d) (Meter B/ Meter C)
U _{ST}	<24V
F _{ST}	16~400Hz

Interfering voltage/current/frequency

Test method	Measuring range	Resolution	Precision
Interference-voltage test	$\pm 1\text{VDC} \sim \pm 50\text{VDC}$ $/1\text{VAC} \sim 50\text{VAC}$	0.1V	$\pm(5\%\text{rdg} + 5\text{dgt})$
Interference-current test	20mA~2A	1mA	$\pm(5\%\text{rdg} + 5\text{dgt})$ (Meter A/ Meter B)
Interference-frequency test	16~400Hz	1Hz	$\pm(1\%\text{rdg} + 10\text{dgt})$.

Maintenance and Repair

1. If it seems that there is a problem with the tester, please make sure that batteries have enough power and the connection of test clamps is in good condition.
2. Before mailing out the tester for service, please take off batteries and properly pack the tester to prevent damages during transportation, and describe the problem in detail; our company is not liable for any damage caused by transportation.
3. The rechargeable battery can be charged about 500 times and used for about 1 year; please replace the rechargeable battery in case the time period for continuous operation decreases significantly with fully charged batteries.

Table of trouble shooting

In case the tester does not function well, please first conduct checks according to the following table.

Problems	Items for check	Measures to be taken
Tester cannot be powered on.	Are batteries installed?	Install new batteries
	Is battery power very low?	
	Does polarity match for the battery?	Check polarity
Batteries cannot be charged. Batteries cannot be charged.	Is the charger correctly attached?	Check if the charger is correctly attached
	Are rechargeable batteries installed?	Install rechargeable batteries.
	Is the charger correctly attached?	Check if the charger is correctly attached
Earthing resistance value is incorrect.	Is the resistance value very small?	The output voltage should be very low when the resistance is low
Communication with PC failed.	Is USB cable correctly installed?	Correctly install the USB cable
Powering off during measurement.	Is battery power insufficient?	Replace the battery

Cleaning

Dip soft cloth in clean water or non-aggressive cleaner, and then wipe and clean the tester. Please do not use benzene type of solvent, alcohol, acetone, ether, ketone, thinner, gasoline, etc., which will cause deformation or decoloration; finally, use dry cloth to wipe it clean.

Disposal

Used testers should be disposed of and the rechargeable battery should be removed in compliance with local laws and regulations.

Note: After replacing new batteries, date and time, etc. should be set again.

Appendix table: Soil resistivity

Soil type	Soil resistivity	Earthing resistance Ω					
		Earthing rod depth (m)			Earthing bar (m)		
	Ωm	3	6	10	5	10	20
Rotten/swamp/wet soil	30	10	5	3	12	6	3
Plantation/sticky soil	100	33	17	10	40	20	10
Sandy soil	150	50	25	15	60	30	15
Wet sandy soil	300	66	33	20	80	40	20
Dry sandy soil	1000	330	165	100	400	200	100
Concrete 1: 5*	400				160	80	40
Wet sand layer	500	160	80	48	200	100	50
Dry sand layer	1000	330	165	100	400	200	100
Stone soil	30000	1000	500	300	1200	600	300
Rock	10000000	-	-	-	-	-	-

If concrete ratio is 1:7, increase the value in the above table by 24%.