

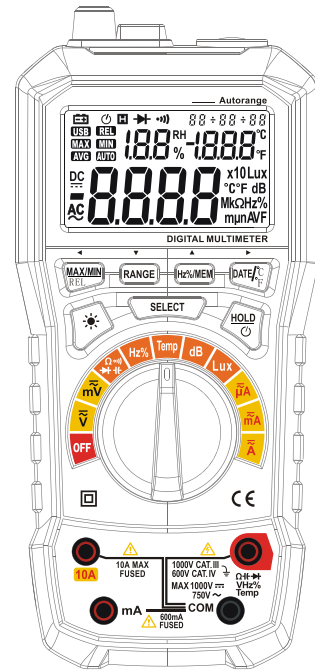

# Multifunctional Digital Multimeter



Y01-03-0115 A0

 Please read this manual carefully before using the product and keep it properly for future use

尺寸 148\*100mm  
黑框不要印

## Contents

1	Statement .....	3
1.1	Safety Statement .....	3
1.2	Safety Information .....	3
1.3	Work Safety Specifications .....	3
2	Overview .....	6
2.1	Display Screen .....	6
2.2	Keys .....	7
2.3	Rotary Switches .....	7
2.4	Input Terminal .....	8
2.5	Top .....	8
3	Measurement Operation .....	9
3.1	Manual and Automatic Range .....	9
3.2	Maximum, Minimum, and Relative Value Measurement .....	9
3.3	AC Voltage Measurement .....	10
3.4	DC Voltage Measurement .....	11
3.5	Frequency and Duty Ratio Measurement .....	12
3.6	AC or DC Measurement .....	13
3.7	Resistance Measurement .....	14
3.8	Connectivity Measurement .....	15
3.9	Capacitance Measurement .....	16
3.10	Diode Measurement .....	17
3.11	Temperature Measurement .....	18
3.11.1	Ambient Temperature Measurement .....	18
3.11.2	Temperature Measurement with Thermocouple .....	18
3.12	Humidity Measurement .....	19
3.13	Illumination Measurement .....	19
3.14	Noise Measurement .....	19
4	Automatic Shutdown Function .....	20
5	Backlight Function .....	20
6	Data Retention .....	20
7	Data Storage .....	21
8	Clock Function .....	21

---

## Contents

---

9	Undervoltage Detection .....	21
10	General Technical Indicators .....	22
11	Accuracy Indicators .....	22
11.1	DCV .....	23
11.2	ACV .....	24
11.3	DC .....	24
11.4	AC.....	25
11.5	Impedance.....	25
11.6	Capacitance.....	26
11.7	Frequency and Duty Ratio.....	27
11.8	Diode Test.....	27
11.9	Connectivity Test .....	28
11.10	Noise (dB).....	28
11.11	Illumination (Lux) .....	28
11.12	Humidity (RH, displayed in the humidity display area) ....	28
11.13	Temperature .....	29
12	Maintenance .....	30
12.1	General Maintenance .....	30
12.2	Battery and Fuse Tube Replacement.....	30
12.1.1	Screw Positions on Rear Cover .....	30
12.2.2	Button Battery .....	30

## 1 Statement

In accordance with the International Copyright Law, any content of this manual shall not be copied in any form (including storage and retrieval or translation into other national or regional languages) without permission and written consent. This manual is subject to change in future versions without prior notice.

### 1.1 Safety Statement

#### Caution

The "caution" symbol indicates conditions and operations that will damage the instrument or device. It requires that care must be taken when performing this operation. Failing to perform this operation correctly or follow the steps of this operation may damage the instrument or device. If these conditions are not met or not fully understood, please do not further perform any relevant operations indicated by the caution symbol.

#### Warning

The "warning" symbol indicates conditions and operations that will be dangerous to the user. It requires that attention must be paid when performing this operation. Failing to perform this operation correctly or follow the steps of this operation may cause personal injury or death. If these conditions are not met or not fully understood, please do not further perform any relevant operations indicated by the warning symbol.

**Before using this instrument, please read the manual carefully and pay attention to the relevant safety warning information**

### 1.2 Safety Information

This instrument is designed according to the safety requirements of the safety standard IEC-61010-1 of the International Electrotechnical Commission for electronic measuring instruments. The instrument is designed and manufactured in strict accordance with the provisions of IEC61010-1 CAT.NI/1000V; CAT.IV/600V overvoltage safety standard and Pollution Degree 2.

### 1.3 Work Safety Specifications











#### Warning

In order to avoid potential safety accidents such as electric shock or personal injury, please practically comply with the following specifications:

- ① Before using the instrument, please read this manual carefully and pay special attention to the safety warning information.
- ② Before using the instrument, please check whether the instrument shell has any crack or damaged plastic part. If so, please stop using it.
- ③ Before using the instrument, please check whether it works normally. If it is abnormal or damaged, please stop using it.
- ④ Before using the instrument, please carefully check the insulator around its input terminal, and stop using it in case of any damage.

- 
- 
- ⑤ Before using the instrument, please check whether the probe is cracked or damaged. If so, please replace the probe with one of the same specifications before use.
  - ⑥ Before use, please check whether the insulation layer of the probe has any damage, exposed metal, or sign of wear, and check the connectivity of the probe. If it is damaged, please stop using it.
  - ⑦ Before using the instrument, please measure a known voltage with the instrument to verify whether the instrument works normally.
  - ⑧ Please strictly follow the operations in this manual to use this instrument, otherwise the protection functions provided by the instrument may be damaged or weakened.
  - ⑨ Please use the instrument according to the measurement category, voltage, or current rating specified on the instrument or in the manual.
  - ⑩ Please wear personal protective equipment (such as certified rubber gloves, masks, flame retardant clothing, etc.) per local and national safety regulations to avoid injury from electric shock and arc when dangerous live conductors are exposed.
  - ⑪ Before connecting the instrument to the circuit measured, please be sure to select the correct input terminal and switch.
  - ⑫ The voltage applied between the input terminals or between any terminal and the grounding point shall not exceed the rated value indicated on the instrument.
  - ⑬ Please take special care when measuring beyond 30V AC true RMS, 42V AC peak, or 60V DC. Such kind of voltage may cause electric shock.
  - ⑭ Please replace the battery in time to prevent measurement errors when the low battery indicator appears on the instrument.
  - ⑮ Do not use the instrument around explosive gas or steam or in a humid environment.
  - ⑯ When measuring, please connect the zero line or grounding wire first before the live line; When disconnecting, please disconnect the live wire before the zero lines and grounding wire.
  - ⑰ Please remove the probe from the instrument before opening the shell or battery cover. Do not use the instrument when it is disassembled, or the battery cover is open.
  - ⑱ The instrument can meet the requirements of safety standards only if it is used with the equipped probe. If the probe is damaged and needs to be replaced, it must be replaced with a probe of the same model and electrical specifications.

## Symbol Definitions:

	High voltage warning
	AC
	DC
	AC or DC
	Warning, important safety sign
	Grounding
	Fuse
	Double insulation or enhanced insulation protection
	Low battery
	The product complies with all relevant European legal requirements
	This additional product label indicates that this electrical/electronic product shall not be discarded in household waste
CAT. III 1000V	Class III, 1,000V Over-voltage Protection
CAT. IV 600V	Class IV, 600V Over-voltage Protection

## 2 Overview

This instrument is a hand-held intelligent multifunctional measuring instrument, which integrates the functions such as measurement of noise, illumination, humidity and temperature, clock, data storage, and digital multimeter. It has a large screen with an LCD digital display (4 groups of data) and backlight, which is easy for users to read. With overload protection and battery Undervoltage indication, it is an ideal multifunctional instrument for professionals, factories, schools, fans, or families.

### 2.1 Display Screen

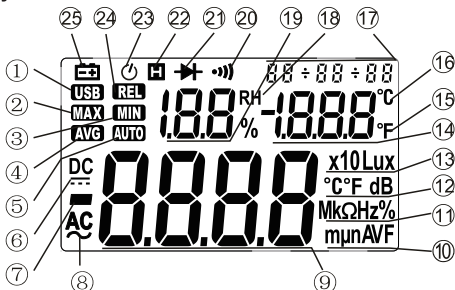

- |  |  |
|--|--|
| ① USB Indicator (N/A)                        | ⑭ Ambient Temperature Display Area                 |
| ② Max Value Indicator                        | ⑮ Ambient Temperature Display Unit, Fahrenheit     |
| ③ Min Value Indicator                        | ⑯ Ambient Temperature Display Unit, Degree Celsius |
| ④ Average Value Indicator (N/A)              | ⑰ Time and Date Display Area                       |
| ⑤ Automatic Range Indicator                  | ⑱ Humidity Symbol and Unit                         |
| ⑥ DCV or DC Indicator                        | ⑲ Humidity Display Area                            |
| ⑦ Minus                                      | ⑳ Connectivity Measurement Indicator               |
| ⑧ ACV or AC Indicator                        | ㉑ Diode Test Indicator                             |
| ⑨ Main Display Area                          | ㉒ Data Retention Indicator                         |
| ⑩ Current, Voltage and Capacitance Unit      | ㉓ Automatic Shutdown Indicator                     |
| ⑪ Resistance and Frequency Unit              | ㉔ Relative Value Measurement Indicator             |
| ⑫ Degree Celsius, Fahrenheit, and Noise Unit | ㉕ Battery Undervoltage Indicator                   |
| ⑬ Illumination Unit                          |  |

## 2.2 Keys

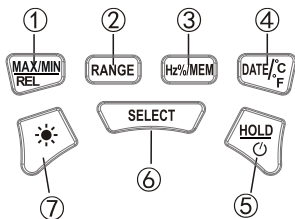

- ① Maximum value, minimum value, and relative value switching key.
- ② Automatic range and manual range switching key
- ③ Frequency (Hz), duty ratio (%), and data storage key.
- ④ Date, time, ambient Degree Celsius and Fahrenheit switching key.
- ⑤ Data retention and automatic sleep switch
- ⑥ Function switching key.
- ⑦ Backlight key.

## 2.3 Rotary Switches

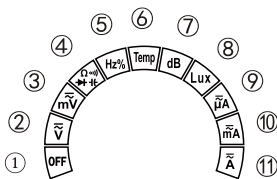

- ① Shutdown gear.
- ② AC or DC voltage (V) gear, press the "SELECT" key to switch between AC and DC.
- ③ AC or DC voltage (mV) gear, press the "SELECT" key to switch between AC and DC.
- ④ Resistance ( $\Omega$ ), diode, connectivity, and capacitance gear, press the "SELECT" key to switch.

- ⑤ Frequency (Hz) and duty ratio (%) gear, press the "SELECT" key to switch.
- ⑥ Temperature (Temp) measurement gear, press the "SELECT" key to switch units.
- ⑦ Noise (dB) measured gear.
- ⑧ Illumination Lux measurement gear, press the "SELECT" key to switch between X1 and X10 units (X10 gear measurement result = displayed value X10).
- ⑨ AC/DC microampere measurement gear, press the "SELECT" key to switch.
- ⑩ AC/DC milliamper measurement gear, press the "SELECT" key to switch.
- ⑪ AC/DC ampere measurement gear, press the "SELECT" key to switch.

## 2.4 Input Terminal

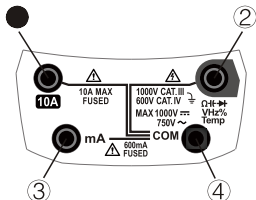

- ① Positive input terminal for AC and DC measurement (up to 10A) and frequency/duty ratio measurement (frequency measurement in current mode).
- ② Positive input terminal for voltage, resistance, capacitance, frequency, and duty ratio measurement. The positive input terminal of K-type thermocouple for temperature measurement.
- ③ Input terminals for AC and DC microampere and milliampere measurement (up to 600mA).
- ④ Common terminals for all measurements; negative input terminal of K-type thermocouple for temperature measurement.

## 2.5 Top

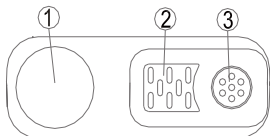

- ① Illumination sensing area, which shall be vertically aligned with the measured light source when measuring illumination.
- ② Ambient temperature and humidity sensing area.
- ③ Noise sensing area, which shall be aligned with the measured noise source when measuring noise.

## 3 Measurement Operation

### 3.1 Manual and Automatic Range

The instrument is provided with manual and automatic ranges. In the automatic range mode, the instrument will select the most suitable range for the detected input, which is convenient for the user to re-select range when changing the measurement signal. The instrument can also be set to the manual range. After the instrument is turned on or the function is switched, it defaults to the automatic range mode, and the instrument displays the "AUTO" symbol. The operation of entering or exiting the manual range mode is as follows:

1. In the automatic range mode, press the "RANGE" key, and the "AUTO" symbol will disappear.
2. Press the "RANGE" key to increase the range. When the maximum range is reached, it will return to the minimum range.
3. Press the "RANGE" key and hold it for two seconds to exit the manual range mode, and the instrument will display the "AUTO" symbol.

**Note: The "RANGE" key is invalid when measuring the duty ratio, diode, connectivity, temperature, noise, and illumination.**

### 3.2 Maximum, Minimum, and Relative Value Measurement

The instrument can measure the maximum, minimum, and relative values. The operation is as follows:

#### **MAX/MIN/REL Mode:**

1. Shortly press the "MAX/MIN/REL" key to select the display mode of maximum value and minimum value.
2. Press the "MAX/MIN/REL" key for the third time to exit the maximum and minimum value measurement mode, and the "MAX" or "MIN" symbol will disappear.

#### **REL Mode:**

1. Set the instrument to the normal measurement function and let the probe contact the measured object you want to set as the reference value.
2. Long press the "MAX/MIN/REL" key to set the measured value as the reference value and enter the relative value measurement mode, and the instrument will display the "REL" symbol.
3. When measuring, the instrument will display the relative value = "actual value - set reference value".
4. Long press and hold the "MAX/MIN/REL" key again to exit the relative value measurement mode, and the "REL" symbol will disappear.

**Note: In the REL mode, the instrument displays the relative value = actual value - set reference value.**

**For the diode, connectivity, ambient temperature & humidity, noise, and illumination measurement, it cannot display the maximum value, minimum value, and relative value.**

### 3.3 AC Voltage Measurement

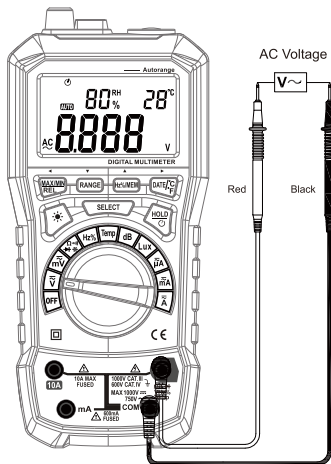

As shown in the figure above, set the instrument to the AC voltage measurement function, contact the circuit measured with the probe, and then read the displayed value, with the procedures as follows:

1. Turn the knob to  $\tilde{V}$  or  $m\tilde{V}$  gear and press the “SELECT” key to set it to the AC voltage function.
2. Insert the red probe into the “V” jack and the black probe into the “COM” jack.
3. Contact the circuit measured with the probe and measure the voltage.
4. Read the measurement result displayed on the screen.

#### **⚠ Attention**

1. Under the AC voltage function, you can press the Hz% key to measure the frequency and duty ratio of AC voltage. Please refer to Frequency Measurement.
2. For AC/DC millivolt (60/600mV) voltage measurement, the maximum range is 600mV, the input impedance is up to 1011 $\Omega$ , and the weak signal measurement is not attenuated, so the measurement accuracy is high. However, it is normal that the probe will display a number when the circuit is open, and it will return to zero in the case of a short circuit. The reading will be stable when the probe contacts the measured target.

## Warning

It is not allowed to measure a voltage higher than 1,000V DC or 750V AC RMS, otherwise, the instrument may be damaged, and the user may suffer electric shock or personal injury.

It is not allowed to apply a voltage higher than 1,000V DC or 750V AC RMS between the common terminal and the earth, otherwise, the instrument may be damaged, and the user may suffer electric shock or personal injury.

### 3.4 DC Voltage Measurement

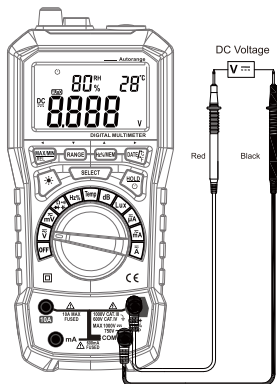

As shown in the figure above, set the instrument to the DC voltage measurement function, contact the circuit measured with the probe, and then read the displayed value, with the procedures as follows:

1. Turn the knob to  $\bar{V}$  or mV gear and press the "SELECT" key to set it to the DC voltage function.
2. Insert the red probe into the "V" jack and the black probe into the "COM" jack.
3. Contact the circuit measured with the probe and measure the voltage.
4. Read the measurement result displayed on the screen.

## Warning

It is not allowed to measure a voltage higher than 1,000V DC or 750V AC RMS, otherwise, the instrument may be damaged, and the user may suffer electric shock or personal injury.

It is not allowed to apply a voltage higher than 1,000V DC or 750V AC RMS between the common terminal and the earth, otherwise, the instrument may be damaged, and the user may suffer electric shock or personal injury.

### 3.5 Frequency and Duty Ratio Measurement

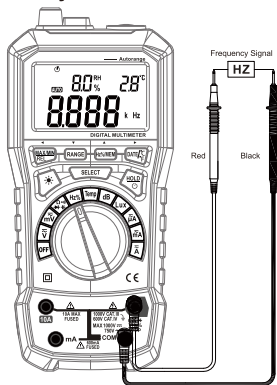

As shown in the figure above, set the instrument to the Hz% measurement function, contact the circuit measured with the probe, and then read the displayed value, with the procedures as follows:

1. Turn the knob to Hz% gear and press the “SELECT” key to switch between frequency and duty ratio.
2. Insert the red probe into the “Hz%” jack and the black probe into the “COM” jack.
3. Contact the circuit measured with the probe and measure the frequency.
4. Read the measurement result displayed on the screen.

**Note:** In order to avoid damaging the instrument or device, do not input frequency or duty ratio signal greater than 10V RMS in Hz% gear.

**When measuring the frequency of high voltage, please select the ACV (AC voltage) gear and press the “Hz%” key to enter the frequency/duty ratio mode. Please refer to the frequency accuracy indicators for the sensitivity and range of frequency measurement in Hz% gear and voltage or current gear.**

#### **Warning**

It is not allowed to measure a voltage higher than 1,54000V DC or 750V AC RMS, otherwise, the instrument may be damaged, and the user may suffer electric shock or personal injury.

It is not allowed to apply a voltage higher than 1,000V DC or 750V AC RMS between the common terminal and the earth, otherwise, the instrument may be damaged, and the user may suffer electric shock or personal injury.

### 3.6 AC or DC Measurement

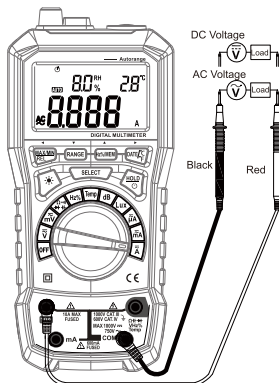

As shown in the figure above, set the instrument to the  $\bar{\mu}\text{A}$ ,  $\bar{\text{mA}}$ ,  $\bar{\text{A}}$  measurement function, connect the probe to the circuit measured in series, and then read the displayed value, with the procedures as follows:

1. Turn the knob to one gear of  $\bar{\mu}\text{A}$ ,  $\bar{\text{mA}}$ ,  $\bar{\text{A}}$  based on the magnitude of the current measured and press the “SELECT” key to set it to AC or DC function.
2. Insert the red probe into the “mA” or “10A” jack based on the current measured and the black probe into the “COM” jack.
3. Switch off the power supply of the circuit measured, connect the meter to the circuit measured in series, and then switch on the power supply of the circuit measured.
4. Read the measurement result displayed on the screen.

#### **Warning**

It is not allowed to measure a voltage higher than 1,54000V DC or 750V AC RMS, otherwise, the instrument may be damaged, and the user may suffer electric shock or personal injury.

The power supply of the circuit measured must be switched off before the instrument is connected to the circuit in series, otherwise, the user may suffer electric shock or personal injury.

The measured current shall not exceed the maximum value set by the instrument, otherwise, it is easy to damage the instrument or safety tube, and the user may suffer electric shock or personal injury. The instrument is set with an alarm for exceeding the maximum current measurement range.

## Caution

To avoid damaging the instrument or device, please check whether the fuse is damaged and use the proper input terminal before measurement.

### 3.7 Resistance Measurement

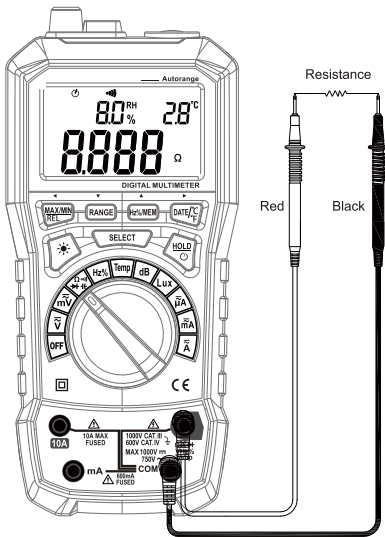

As shown in the figure above, set the instrument to the  measurement function, contact the circuit measured with the probe, and then read the displayed value, with the procedures as follows:

1. Turn the knob to  gear and press the “SELECT” key to set it to the resistance measurement function.
2. Insert the red probe into the “Ω” jack and the black probe into the “COM” jack.
3. Contact the circuit measured or two ends of the resistor with the probe.
4. Read the measurement result displayed on the screen.

## Warning

Before measuring resistance, connectivity, capacitance, or diode, please switch off the power supply and discharge all high-voltage capacitors, otherwise the instrument may be damaged, and the user may suffer electric shock or personal injury.

### 3.8 Connectivity Measurement

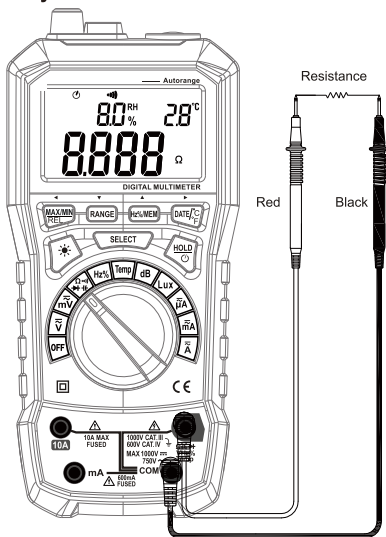

As shown in the figure above, set the instrument to the  $\Omega$  measurement function, contact the circuit measured with the probe, and then read the displayed value, with the procedures as follows:

1. Turn the knob to  $\Omega$  gear and press the “SELECT” key to set it to the connectivity measurement function.
2. Insert the red probe into the “ $\Omega$ ” jack and the black probe into the “COM” jack.
3. Contact the circuit measured or two ends of the resistor with the probe.
4. If the resistance of the measured resistor or circuit is less than 50 $\Omega$ , the buzzer will sound.

#### Warning

Before measuring resistance, connectivity, capacitance, or diode, please switch off the power supply and discharge all high-voltage capacitors, otherwise the instrument may be damaged, and the user may suffer electric shock or personal injury.

### 3.9 Capacitance Measurement

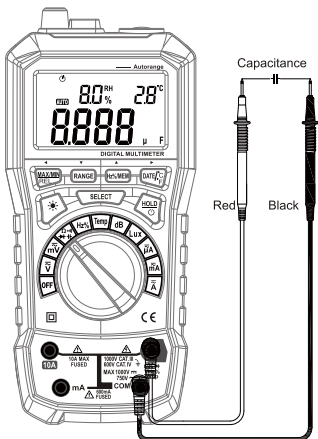

As shown in the figure above, set the instrument to the  $\Omega$  measurement function, contact the capacitor measured with the probe, and then read the displayed value, with the procedures as follows:

1. Turn the knob to  $\Omega$  gear and press the “SELECT” key to set it to the capacitor measurement function.
2. Insert the red probe into the “ $\Omega$ ” jack and the black probe into the “COM” jack.
3. Contact the two ends of the capacitor with the probe.
4. Read the measurement result displayed on the screen.

#### **Warning**

Before measuring resistance, connectivity, capacitance, or diode, please switch off the power supply and discharge all high-voltage capacitors, otherwise the instrument may be damaged, and the user may suffer electric shock or personal injury.

#### **Attention**

1. When the input circuit is open, the instrument may display a reading. If so, press the “REL” key to return it to zero before measuring.
2. When measuring a small capacitor (below 100nF), it is best to turn on the relative value measurement function to reduce the measurement error caused by the base number of the probe or instrument.
3. When measuring a large capacitor, it will take a certain period to stabilize the reading (e.g., about 30s for 100 $\mu$ F).

### 3.10 Diode Measurement

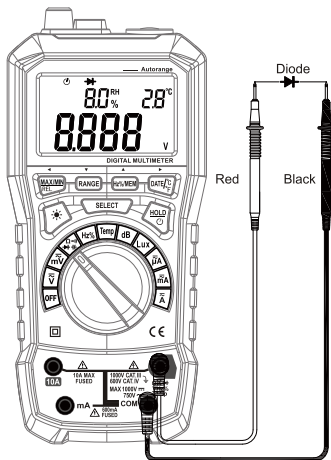

As shown in the figure above, set the instrument to the  $\Omega$  measurement function, contact the diode measured with the probe, and then read the displayed value, with the procedures as follows:

1. Turn the knob to  $\Omega$  gear and press the “SELECT” key to set it to the diode measurement function.
2. Insert the red probe into the “ $\rightarrow$ ” jack and the black probe into the “COM” jack.
3. Contact the anode of the diode measured with the red probe and the cathode of the diode with the black probe.
4. Read the measurement result displayed on the screen.

#### **Warning**

Before measuring resistance, connectivity, capacitance, or diode, please switch off the power supply and discharge all high-voltage capacitors, otherwise the instrument may be damaged, and the user may suffer electric shock or personal injury.

#### **Attention**

The forward bias of a typical diode ranges from 0.3V to 0.8V; however, the reading may vary with the different resistance of other circuits between the probes.

---

## 3.11 Temperature Measurement

The instrument can measure ambient temperature and measure temperature with a thermocouple.

### 3.11.1 Ambient Temperature Measurement

The instrument can measure ambient temperature. After the instrument is turned on (all gears except the OFF gear), the current ambient temperature will be displayed in the ambient temperature display area. Long press the "DATE/°C°F" key to switch the ambient temperature unit; It only needs to place the instrument in the measured environment to get the ambient temperature.



#### Attention

1. As the ambient temperature sensor is placed inside the top of the instrument, and it takes a long time to reach a thermal balance with the measured environment, the instrument needs to be placed in the measured environment for a long time to obtain a more accurate ambient temperature reading.
2. The instrument is not suitable for measuring rapidly changing ambient temperature.
3. Since the temperature sensor for ambient temperature measurement is placed inside the instrument, it can only measure the ambient temperature ranging from 0 to 40°C.



#### Attention

The instrument is likely to display temperatures beyond the range of 0-40°C, but the measurement accuracy cannot be guaranteed, and the instrument may be damaged.

### 3.11.2 Temperature Measurement with Thermocouple

1. Turn the knob to the TEMP gear.
2. Insert the thermocouple into the input jack of the instrument, insert the positive end (red) of the thermocouple into the "Temp" jack and the negative end (black) into the "COM" jack.
3. Contact the measured object with the thermocouple probe and read the result in the main display area on the screen.
4. Press the "SELECT" key to switch the unit between degrees Celsius and Fahrenheit.

---

### 3.12 Humidity Measurement

Place the instrument in the measured environment, turn on the instrument (all gears except the OFF gear), and the instrument humidity display area displays the current ambient humidity.

#### Attention

1. As the humidity sensor is placed inside the top of the instrument, and it takes a long time to reach a balance with the measured environment, the instrument needs to be placed in the measured environment for a long time to obtain a more accurate humidity reading.
2. The instrument is not suitable for measuring rapidly changing ambient humidity.

### 3.13 Illumination Measurement

1. Turn the knob to the Lux gear.
2. Vertically align the illumination sensing area at the top of the instrument with the measured light source.
3. Read the measurement result displayed on the screen.

#### Attention

**When measuring illumination, the minimum distance between the luminous surface of the light source and the illumination sensing area of the instrument shall be greater than 15 times the maximum size of the luminous surface of the light source.**



### 3.14 Noise Measurement

1. Turn the knob to the dB gear.
2. Align the noise receiving area at the top of the instrument with the measured noise source.
3. Read the measurement result displayed on the screen.

#### Attention



**Because strong wind (more than 10m/s) will affect the microphone and cause a reading error, please install a windshield in front of the microphone when measuring in strong wind.**

## 4 Automatic Shutdown Function

- ① If there is no operation within 10 minutes after startup, the instrument will enter the sleep state to save battery power.
- ② After automatic shutdown, press the " " key to wake up the instrument within 1-2 seconds, and the instrument will return to the working state.
- ③ Long press the " " key to switch off or turn on the automatic shutdown function in the measurement mode.





## 5 Backlight Function

The instrument is equipped with a backlight to facilitate users to accurately read the measurement results in places with poor lighting conditions. You can take the following steps to turn on or off the backlight:



1. Press the " " key to turn on the backlight, and the backlight will be automatically turned off after 10 seconds.
2. Long press the " " key for 1 second to turn on the backlight, and the backlight will not be turned off automatically.
3. When the backlight is on, press the " " key again to turn off the backlight.

### Attention

As the light-emitting body of the backlight is LED with a large working current, using the backlight frequently will shorten the battery lifespan even if the instrument is set with a timing circuit (the time set is about 10 seconds, that is, the backlight will be automatically turned off about 10 seconds after it is turned on). Therefore, try not to use the backlight unless it is necessary.

When the battery voltage is less than or equal to 3.8V, the screen displays the " " (Undervoltage) symbol. However, when the backlight is used, even if the battery voltage is greater than 3.8V, the battery voltage will drop due to the large working current of the backlight, and the " " symbol may be displayed (the measurement accuracy cannot be guaranteed when the " " symbol is displayed). At this time, the battery may not be replaced, and the instrument can be used normally without the backlight until the " " symbol is displayed again.





## 6 Data Retention

1. In the process of measurement, if the reading needs to be retained, you can press the " " key, and the displayed value will be locked.
2. Press the " " key again to release the reading hold state.

## 7 Data Storage

### Attention

This function can only support a total of 8 kinds of data, including ACV, DCV, ACA, DCA, Res, Cap, dB, and Lux, and store 100 figures for each kind.

- ① Data storage mode: Long press “Hz%/MEM” to enter, press “RANGE” key and “Hz%/MEM” key to select the storage address and display the data, press “” key to save the data, and press “” key to exit the mode.
- ② Data reading mode: “SELECT” key + shortly press “Hz%/MEM” key to enter, press “RANGE” key and “Hz%/MEM” key to select the storage address and display the data. Press “” to exit the mode.
- ③ Data clearing: In the storage or reading mode, long press the “” key to clear all the data of the current address group (Address 0-9 is the first group, 10-19 is the second group... and so on, totally 10 groups)

## 8 Clock Function



The instrument is equipped with the clock function, xx-xx-xx (yy/mm/dd) or XX:XX:X (h:m:s).

- ① Press the “DATE” key in the measurement mode to switch between date and time.
- ② Set time and date mode: In the working mode, long press the “SELECT” key + “DATE/°C°F” to enter, shortly press “MAX/MIN/REL” key and “DATE/°C°F” key to select the year, month, day, hour, minute and second from the left or the right, and shortly press “Hz%/MEM” key or “RANGE” key to increase or decrease the number. Press the “” key to save time and exit.

### Attention

Only the last 2 digits of the year will be displayed.

## 9 Undervoltage Detection

1. When the voltage of four 1.5V 5# batteries is less than 3.8V, the “” (Undervoltage) symbol is always on.
2. When the voltage of the spare button battery CR2032 for the clock is less than 2V, the “” (Undervoltage) symbol flashes.

## 10 General Technical Indicators

Environmental Conditions for Use: 600V CAT.IV and 1,000V CAT.III

Pollution Degree: 2

Altitude: <2,000 m

Ambient Temperature and Humidity for Operation: 0-40°C (<80% RH, <10°C non-condensing)

Ambient Temperature and Humidity for Storage: -10-60°C (<70% RH, battery removed)

Temperature Coefficient: 0.1\*accuracy/°C (<18°C or >28°C)

Maximum Allowable Voltage between Measuring Terminal and Earth: 1,000V DC or 750V AC RMS

Fuse Protection: mA gear; fuse F600mA/250V;

10A gear: F10A/250V

Sampling Rate: about 3 times/s

Display: 6,000 count/display, independent display of temperature and humidity, The unit symbol is automatically displayed based on the measurement function and gear

Overrange Indication: display "OL"

Battery Undervoltage Indication: when the battery voltage is lower than the normal working voltage, "⊖+" will be displayed

Input Polarity Indication: the "—" symbol will be automatically displayed

Power Supply: 4 x 1.5V AA battery

Overall Dimensions: 204 (L) \* 94 (W) \* 57 (H) mm

Weight: about 410g (including battery)

## 11 Accuracy Indicators

Accuracy is applicable within 1 year after calibration.

Reference Conditions: ambient temperature 18°C to 28°C, relative humidity no more than 80%

Accuracy: ±(% reading + word)

## 11.1 DCV

Range	Resolution	Accuracy	<p>(1) Input impedance: <math>1011\Omega</math> (input impedance is <math>1011\Omega</math> for 60/600mV range).</p> <p>(2) Overload protection: 1,000V DC or 750V AC (RMS).</p> <p>(3) Maximum input voltage: 1,000V DC.</p> <p>(4) Attention: when measuring the voltage at mV gear, as the input impedance is up to <math>1011\Omega</math>, and the weak signal measurement is not attenuated, so the measurement accuracy is high. However, it is normal that the probe will display a number when the circuit is open, and it will return to zero in the case of a short circuit. The reading will be stable when the probe is inserted into the measured point.</p>
60mV	0.01mV	$\pm(0.7\%$ reading +2 words)	
600mV	0.1mV		
6V	1mV		
60V	10mV		
600V	100mV		
1,000V	1V		

## 11.2 ACV

Range	Resolution	Accuracy	<p>(1) Input impedance: 1011Ω (input impedance is 1011Ω for 60/600mV range).</p> <p>(2) Overload protection: 1,000V DC or 750V AC (RMS).</p> <p>(3) Maximum input voltage: 1,000V DC.</p> <p>(4) Attention: when measuring the voltage at mV gear, as the input impedance is up to 1011Ω, and the weak signal measurement is not attenuated, so the measurement accuracy is high. However, it is normal that the probe will display a number when the circuit is open, and it will return to zero in the case of a short circuit. The reading will be stable when the probe is inserted into the measured point.</p>
60mV	0.01mV	± (0.8% reading+3 words)	
600mV	0.1mV		
6V	1mV		
60V	10mV		
750V	100mV	± (1.0% reading+3 words)	

Frequency range: 10~1000Hz<sub>o</sub>

## 11.3 DCA

Range	Resolution	Accuracy	<p>(1) Overload protection: μA/mA range: 600mA/250V fuse tube (fast-acting fuse tube), 10A range: 10A/250V fuse tube (fast-acting fuse tube).</p> <p>(2) Maximum input current: mA hole: 600mA, 10A hole: 10A.</p> <p>(3) AC test frequency range: 10-1,000Hz AC test response: True RMS.</p> <p>(4) Attention: when measuring high current, the continuous measurement time shall not be longer than 15 seconds. After measurement, the instrument shall be cooled down for more than twice the measurement time before starting the low current test.</p>
600μA	0.1μA	± (1.2% reading+3 words)	
6,000μA	1μA		
60mA	10μA		
600mA	100μA		
6A	1mA		
10A	10mA	± (2.0% reading+10 words)	

## 11.4 ACA

Range	Resolution	Accuracy	<p>(1) Overload protection: <math>\mu\text{A}/\text{mA}</math> range: 600mA/250V fuse tube (fast-acting fuse tube), 10A range: 10A/250V fuse tube (fast-acting fuse tube).</p> <p>(2) Maximum input current: mA hole: 600mA, 10A hole: 10A.</p> <p>(3) AC test frequency range: 10-1,000Hz AC test response: True RMS.</p> <p>(4) Attention: when measuring high current, the continuous measurement time shall not be longer than 15 seconds. After measurement, the instrument shall be cooled down for more than twice the measurement time before starting the low current test.</p>
600 $\mu\text{A}$	0.1 $\mu\text{A}$	$\pm (1.5\% \text{ reading} + 3 \text{ words})$	
6,000 $\mu\text{A}$	1 $\mu\text{A}$		
60mA	10 $\mu\text{A}$		
600mA	100 $\mu\text{A}$		
6A	1mA		
10A	10mA	$\pm (3.0\% \text{ reading} + 10 \text{ words})$	

## 11.5 Impedance

Range	Resolution	Accuracy	<p>(1) Open-circuit voltage: About 0.5V</p> <p>(2) Overload protection: 1,000V DC or 750V AC (RMS)</p>
600 $\Omega$	0.1 $\Omega$	$\pm (1.2\% \text{ reading} + 5 \text{ words})$	
6k $\Omega$	1 $\Omega$		
60k $\Omega$	10 $\Omega$		
600k $\Omega$	100 $\Omega$		
6M $\Omega$	1K $\Omega$		
60M $\Omega$	10K $\Omega$	$\pm (2.0\% \text{ reading} + 5 \text{ words})$	

## 11.6 Capacitance

Range	Resolution	Accuracy	<p>(1) Overload protection: 1,000V DC or 750V AC (RMS).</p> <p>(2) Attention: The parameters exclude the error caused by the capacitance of the probe and the capacitance base (it may be up to several nF in the range of 100nF). Users can use the relative value measurement function to reduce errors.</p>
10nF	0.001nF	±(3.0% reading +3 words)	
100nF	0.01nF		
1,000nF	0.1nF		
10uF	0.001uF		
100uF	0.01uF		
1,000uF	0.1uF		
10mF	0.001mF		

## 11.7 Frequency and Duty Ratio

Range	Resolution	Accuracy	
9.999Hz	0.001Hz	±(1.0% reading+5 words)	Through Hz gear: 1) Measurement range: 0-10MHz 2) Input voltage range: 0.5-10V AC (RMS) (the input voltage shall increase with the increase of measured frequency) 3) Overload protection: 1,000V DC or 750V AC (RMS) Through V gear: 1) Measurement range: 0-100kHz 2) Input voltage range: 0.5-750V AC (RMS) (the input voltage shall increase with the increase of measured frequency) 3) Maximum input voltage: 1,000V DC or 750V AC (RMS) Through $\mu$ A, mA or A gear: 1) Measurement range: 0-100kHz 2) Input signal range: $\geq$ 1/4 range (the input current shall increase with the increase of measured frequency) 3) Input protection: $\mu$ A and mA range: F 600mA/250V; 10A range: F10A/250V
99.99Hz	0.01Hz		
999.9Hz	0.01Hz		
9.999kHz	0.001kHz		
99.99kHz	0.01kHz		
999.9kHz	0.1kHz		
9.999MHz	0.001MHz		
0.1 ~ 99.9%	0.1%	±3.0%	

### Attention

The frequency measuring range in the Hz gear is larger than that measured by the “Hz” function in the voltage and current gear, but the measured value beyond the range in the above table can only be used for reference.

## 11.8 Diode Test

Range	Resolution	Function	
	1mV	Display the approximate diode forward voltage value	(1) Open-circuit voltage: about 3.2V (2) Overload protection: 1,000V DC or 750V AC (RMS)

## 11.9 Connectivity Test

Range	Function	
	If the resistance of the measured circuit is less than or equal to 50Ω, the buzzer inside the instrument will sound.	(1) Open-circuit voltage: about 1V (2) Overload protection: 1,000V DC or 750V AC (RMS)

## 11.10 Noise (dB)

Range	Resolution	Accuracy	
40-100dB	0.1 dB	±3.5%dB at 94dB,1kHz sinusoidal wave	Frequency range: 100-8,000Hz

## 11.11 Illumination (Lux)

Range	Resolution	Accuracy	
Lux (4,000)	1 Lux	(5.0% reading + 10 words) Calibrated under standard incandescent lamp and color temperature of 2,856K.	Repeatability: ±2%
X10Lux(40,000)	10 Lux		

## 11.12 Humidity (RH, displayed in the humidity display area)

Range	Resolution	Accuracy	
20-95%	0.1%	±5.0%RH	Working Temperature: 0°C-40°C Sampling Period: about 20 seconds

## 11.13 Temperature

### Ambient Temperature (temperature display area)

Range	Resolution	Accuracy		Sampling Period: 0.5 second
°C	0.1°C	0°C to 40°C	±2°C	
°F	0.1°F	32°F to 104°F	±4°F	

### Temperature Measurement with Thermocouple (main display area)

Range	Resolution	Accuracy		Overload protection: 1,000V DC or 750V AC (RMS)
°C	1°C	-20°C~ 0°C	±5.0% reading or ±3°C	
		0°C ~ 400°C	±1.0% reading or ±2°C	
		400°C~1000°C	±2.0% reading	
°F	1°F	-4°F~32°F	±5.0% reading or ±6°F	
		32°F~752°F	±1.0% reading or ±4°F	
		752°F~1832°F	±2.0% reading	

## 12 Maintenance

### 12.1 General Maintenance

Clean the shell of the instrument regularly with a wet cloth and mild detergent. Do not use corrosives or solvents.

Dirty or wet input jacks may affect the measurement. To clean the input jacks, please:

1. Switch off the instrument and remove all test probes.
2. Clean the dirt on the input jacks.
3. Wipe the inside of each input jack with a new cotton swab dipped with isopropyl alcohol.
4. Apply a thin layer of high-quality engine oil inside each jack with a new cotton swab.

### 12.2 Battery and Fuse Tube Replacement

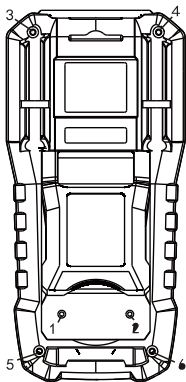

12.2.1 Screw Positions on Rear Cover

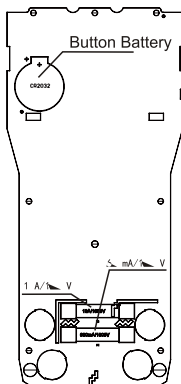

12.2.2 Button Battery

### **Steps to replace four AA batteries (1.5V):**

1. Open the instrument support frame.
2. Loosen the screws ① and ②.
3. Remove the battery cover.
4. Replace the batteries.
5. Install the battery cover back and tighten the screws.

### **Steps to replace CR2032 button battery or fuse tube:**

1. Loosen the screws ③ ④ ⑤ ⑥.
2. Open the rear cover of the product.
3. Refer to the location figure of the button battery and fuse tube to replace the parts needed.
4. Install the rear cover of the instrument back and tighten the screws.



### **Warning**

- ① In order to ensure the safe operation and maintenance of the product, please take out the batteries if the product will not be used for a long time, so as to prevent electric leakage and damage to the product.
- ② In order to prevent possible electric shock, fire, or personal injury: only the same fuse wire can be used to replace the blown one to prevent the danger caused by arc flash.
- ③ Please use the specified fuse replacement.
- ④ The batteries contain dangerous chemicals that may cause burns or explosions.
- ⑤ If you come into contact with chemicals, please wash with water and seek medical advice in time.
- ⑥ When the low battery power indication is displayed, please replace the batteries in time to prevent incorrect measurement.