Table of Contents

1. Safety Information	1
1.1 Preparation.....	1
1.2 Symbol.....	2
1.3 Maintenance.....	2
2. Description	3
2.1 Part name	3
2.2 Rotary switch and button as well as input jack description.....	4
2.3 LCD display.....	4
3. Specification	5
3.1 Overview	5
3.2 Technical indexes	6
4. Operation guide	8
4.1 Reading hold	8
4.2 Back-light / Torch.....	8
4.3 Automatic shutdown	9
4.4 Measurement preparation.....	9
4.5 Start low-pass filtering (only limited to AC current)	10
4.6 Non-contact voltage detection (NCV)	10
4.7 AC & DC current measurement.....	11
4.8 AC & DC voltage measurement	12
4.9 Resistance measurement	13
4.10 Measure AC current (or DC current) and AC	

& DC voltage at the same time	13
4.11 Measure AC current (or DC current) and resistance at the same time	15
5. Maintenance.....	16
5.1 Change battery.....	16
5.2 Change pens.....	17
6. Accessories	17

1. Safety Information



Pay special attention to use of this instrument, for improper use may cause electric shock or damage to instrument. During use, observe usual safety regulations and observe safety measures regulated in use manual.

In order to make full use of instrument functions and guarantee safe operation, please carefully read and observe use methods in this manual.





Instrument complies with safety requirements on electronic measuring instrument of IEC-61010-1, IEC-61010-2-030 and IEC-61010-2-032, level II pollution, and over-voltage standard is CAT IV 600V.

Please observe safety operation guide, and guarantee to use instrument in a safe manner.

1.1 Preparation

- ⇒ When using this instrument, users must observe standard safety rules:
 - General electric shock prevention.
 - Prevention of misuse of instrument.
- ⇒ After receiving the instrument, check whether it is damaged during transportation.
- ⇒ After storing and shipping under adverse conditions, check whether the instrument has been damaged.
- ⇒ Pens of the instrument must be in good condition. Before use, check whether insulation of pens is damaged, and whether metal wire is exposed.

1.2 Symbol

	Note (refer to use manual for important safety information)
	Able to be used on dangerous electrified conductors.
	Dual-insulation protection (Category II)
CAT IV	Over-voltage according to IEC-61010-1 standard (installation), level IV, pollution degree 2 refers to protection level of pulse withstand voltage provided.
	Comply with EU standard.
	Grounded

1.3 Maintenance

- ⇒ Do not try to open bottom case to adjust or repair instrument, for such operation could only be conducted by technicians fully understanding the instrument and electric shock danger.
- ⇒ Before opening instrument bottom case or battery cover, remove the pens from the wire being measured.
- ⇒ In order to avoid electric shock possibly caused by error reading, when symbol " displays on instrument, replace battery immediately.
- ⇒ Use wet cloth and gentle detergent to clean the instrument, and do not use any abrasive or solvent.
- ⇒ Power off when the instrument is not used, and rotate range switch to OFF position.
- ⇒ If the instrument is not used for a long time, take out the battery to avoid any damage to the instrument.

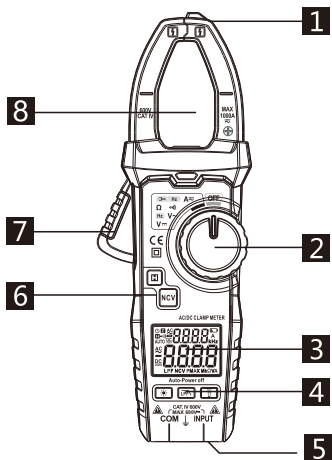

2. Description

2.1 Part name







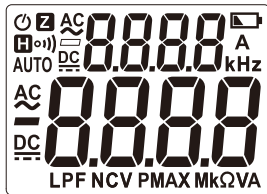

- 1** Non-contact voltage detecting & inducing area
- 2** Rotary switch
- 3** Liquid crystal display (LCD)
- 4** Function key
- 5** Input socket
- 6** Function key
- 7** Trigger
- 8** Current clamp: Used in current measurement

2.2 Rotary switch and button as well as input jack description

OFF	Instrument off gear
	Measurement gear.
V Ω \cdot) COM	DC voltage, AC voltage, resistance and buzzer input terminal.
	Current input transformer

2.3 LCD display



	AC & DC
	Connection/Disconnection indication
AUTO	Automatic scan mode
	Automatic shutdown indication
	Low battery
	Reading hold state
V, A	Volt (voltage), ampere (current)
Ω , k Ω , M Ω	ohm, kilohm and megohm (resistance)

Hz, kHz ,	hertz, kilohertz
NCV	Non-contact voltage detection
LPF	Low-pass filtering

3. Specification

The instrument specifies one year as a cycle, and shall be re-calibrated under 18°C ~ 28°C, with relative humidity less than 75%.

3.1 Overview

- Select measurement function and range automatically.
- Overload protection throughout the range.
- Max. voltage between measurement terminal and ground:
600V DC or 600V AC
- Operating height: Max. 2000m
- Display: LCD
- Max. display value: 6000 digit.
- Polarity indication: Automatic indication, and '-' indicates negative.
- Over range display: 'OL' or '-OL' .
- Sampling time: About 3 times/second.
- Unit display: Function and electricity quantity unit display.
- Automatic shutdown time: 10 minutes
- Power supply: 1.5V AAA battery × 3
- Battery under-voltage indication: LCD display  symbol
- Temperature coefficient: Less than 0.1×accuracy/°C.
- Operating temperature: 18°C ~ 28°C.
- Storage temperature: -10°C ~ 50°C.

3.2 Technical indexes

3.2.1 AC current

Range	Resolution	Accuracy
60A	0.01A	± (2.5% reading + 8 digits)
600A	0.1A	
1000A	1A	

- Min. input current: 0.2A AC current.
- Max. input current: 1000A AC current.
- Frequency range: 45 ~ 65Hz;

3.2.2 DC current

Range	Resolution	Accuracy
60A	0.01A	± (3% reading + 10 digits)
600A	0.1A	
1000A	1A	

- Min. input current: 0.3A DC current

3.2.3 DC voltage

Range	Resolution	Accuracy
6V	0.001V	± (0.5% reading + 3 digits)
60V	0.01V	
600	0.1V	

- Min. input voltage 0.5V DC
- Max. input voltage: 600V DC

3.2.4 AC voltage

Range	Resolution	Accuracy
6V	0.001V	±(0.8% reading + 5 digits)
60V	0.01V	
600V	0.1V	

- Min. input voltage: 1.0V AC
- Max. input voltage: 600V AC (valid value)
- Frequency range: 45 ~ 65Hz

3.2.5 Frequency

3.2.5.1 Clamp frequency measurement (via gear A):

Range	Resolution	Accuracy
60.0Hz	0.1Hz	± (1.0% reading + 5 digits)
1000Hz	1Hz	

- Measurement range: 40Hz ~ 1000Hz
- Input signal range: ≥ 2A AC current (valid value)

3.2.5.2 Via gear V:

Range	Resolution	Accuracy
60.0Hz	0.1Hz	± (1.0% reading + 5 digits)
1000Hz	1Hz	

- Measurement range: 40Hz ~ 1000Hz
- Input signal range: ≥ 0.8V AC voltage (valid value)

3.2.6 Resistance

Range	Resolution	Accuracy
6k Ω	0.001k Ω	\pm (0.8% reading + 3 digits)
60k Ω	0.01k Ω	
600k Ω	0.1k Ω	
6M Ω	0.001M Ω	
10M Ω	0.01M Ω	

- Overload protection: 600V DC or AC (valid value)

3.2.7 Line on-off test

Range	Resolution	Function
	1 Ω	If resistance of the line being measured is less than 50, buzzer attached in the instrument may sound.

- Overload protection: 600V DC or AC (valid value)

4. Operation guide

4.1 Reading hold

During measurement, if it is required to hold reading, touch



button, value on display will be locked, touch



button again, to cancel reading hold.

4.2 Back-light / Torch

- ◆ During measurement, if environment light is too dark, causing it difficult to read, press button/ button, to open back-light or flashlight, which will turn off

automatically about 1 minute later.

- ◆ During this period, press  /  button to turn off back-light.

4.3 Automatic shutdown

- ◆ If there's no operation within 10 minutes after start, instrument will enter standby state, and shut down to save energy. Within 2 minutes before shutdown, buzzer will prompt once every 1 minute.
- ◆ Press " NCV " button during start, to cancel the automatic shutdown function.

4.4 Measurement preparation

- ◆ Turn on change-over switch, to power on. If battery voltage is low (about $\leq 2.4V$), display will show " " symbol, in this case, change the battery.
- ◆ When instrument is not measured, it will enter automatic scan state, and instrument display is shown in the following figure.

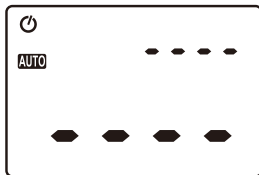

4.5 Start low-pass filtering (only limited to AC current)

Press LPF button to enable or disable low-pass filtering function, when low-pass filtering function is enabled, measurement value will attenuate -3dB at 1kHz.

4.6 Non-contact voltage detection (NCV)

- ◆ Press NCV button for 2 seconds, to enable NCV function, and instrument displays

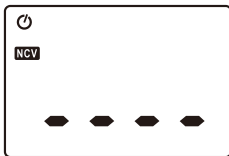

- ◆ Press NCV button, to close NCV detector to the lead being measured, instrument could detect whether the lead being measured is >90V AC voltage. When instrument detects AC voltage, instrument buzzer will alarm while NCV indicator will flash.

Note:

- ◆ Even if there's no alarm indication, voltage could still exist. Do not judge whether there's voltage in lead depending on non-contact voltage detector. Detection may be impacted by factors such as different socket designs, and insulation thickness types etc.
- ◆ In NCV detection mode, instrument will not measure voltage, resistance or current at the same time.

4.7 AC & DC current measurement

- ◆ Hold trigger, and open clamp, to clip one lead of the line being measured.
- ◆ When measured signal is $>0.2\text{A}$ (AC), primary display of instrument will show current value measured, and secondary display will show frequency value of current (note: Instrument will show frequency value only when AC current value is $>2\text{A}$).
- ◆ When measured signal is $>0.3\text{A}$ (DC), primary display of instrument will show current value measured.

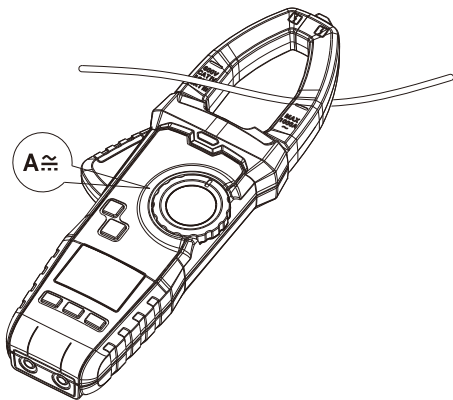

4.8 AC & DC voltage measurement

- ◆ Connect the pens to the signal being measured, when measured signal is $\geq 0.5V$, instrument will show DC voltage value being measured. When measured signal is $< 0.5V$, instrument will use resistance value by default, and display internal resistance value of the signal being measured.
- ◆ Connect the pens to measured signal, when measured AC signal is $\geq 1.0V$, primary display of instrument will show currently measured AC voltage, while secondary display will show frequency of voltage. When measured AC signal is $< 1.0V$, instrument will use resistance value by default, and display internal resistance value of the signal being measured.

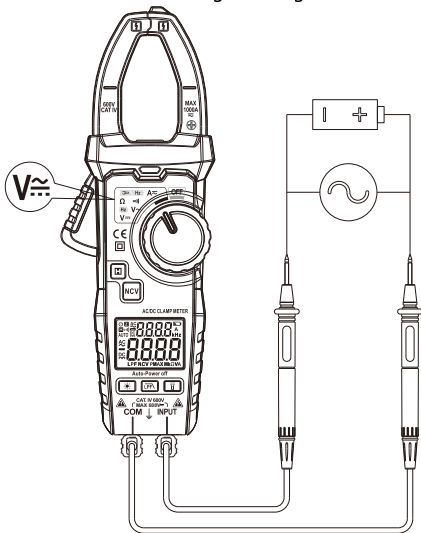

4.9 Resistance measurement

Connect the pens with measured resistance, when measured resistance is $>10\text{M}\Omega$, instrument will display ----, when measured resistance is less than 50Ω , instrument buzzer will make an alarming sound.

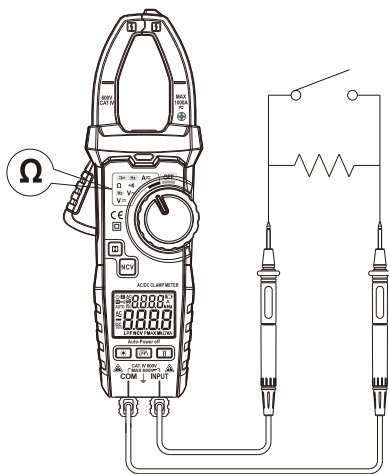

4.10 Measure AC current (or DC current) and AC & DC voltage at the same time

- ◆ Hold trigger, open clamp, and clip one lead of measured line into the clamp, when measured signal is $>0.2\text{A}$ (AC current is 0.2A , and DC current is 0.3A), secondary display of instrument will show measured current.

- ◆ Connect the pens to measured signal, when measured AC signal is $\geq 1.0V$, primary display of instrument will show currently measured AC voltage. When measured AC signal is $< 1.0V$, instrument will use resistance value by default, and display internal resistance value of the signal being measured.
- ◆ When measured DC signal is $\geq 0.5V$, primary display of instrument will show DC voltage being measured. When measured DC signal is $< 0.5V$, instrument will use resistance value by default, and display internal resistance value of the signal being measured.

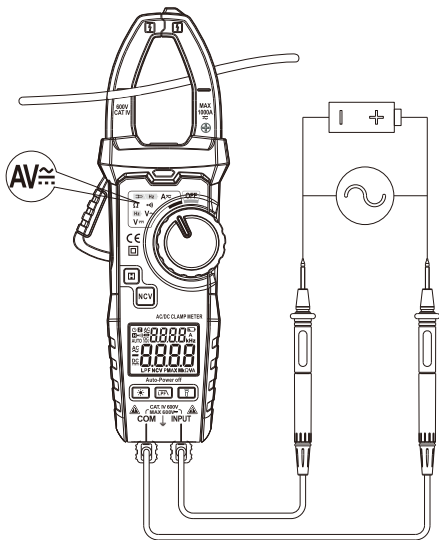

4.11 Measure AC current (or DC current) and resistance at the same time

- ◆ Hold trigger, open clamp, and clip one lead of measured line into the clamp, when measured signal is $>0.2\text{A}$ (AC current is 0.2A , and DC current is 0.3A), secondary display of instrument will show measured current.
- ◆ Connect the pens with measured resistance, when measured resistance is $>10\text{M}\Omega$, instrument will display ----, when measured resistance is less than 50Ω , instrument buzzer will make an alarming sound.

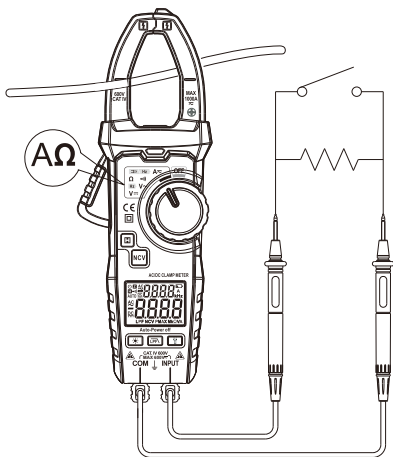

5. Maintenance

5.1 Change battery

WARNING



Before opening battery cover of the instrument, remove the pens from the circuit being measured, to avoid electric shock.

- 1 If symbol "  " appears, it indicates to change the battery.
- 2 Unfasten bolts on battery cover of instrument and remove the cover.
- 3 Change the old battery.
- 4 Place the battery cover.

Note:

Do not reverse battery polarity.

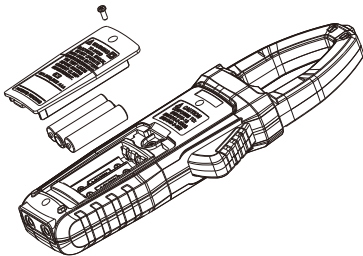

5.2 Change pens



When changing the pen, it is required to replace with an identical pen or a pen of the same level. The pen must be in good condition, and level of the pens is: 1000V 10A.

If insulation layer of the pen is damaged, or metal wire of the lead exposes, it is required to change the pen.

6. Accessories

①	Pens	Level: 1000V 10A	1
②	Use Manual		1
③	Battery	1.5V AAA battery	3
④	Cloth bag		1