

Table of Contents

Safety information	1
Symbol explanation	2
Safety precautions.....	3
Maintenance.....	4
General description	4
Layout(forward)	5
Panel description.....	6
Operating instructions.....	9
DC voltage measurement	9
AC voltage measurement.....	9
DC Current measurement	9
AC current measurement	10
Resistance measurement	10
Diode test	11
Continuity testing	12
Capacitance measurement	12
Frequency measurement	12
Temperature measurement	13
Duty test	14
Specifications	14
General	14
Measurement specifications.....	15
Auto power off	18
Replacing the battery.....	18
Accessories.....	19

Safety information









The AC/DC clamp meter has been designed according to IEC1010 – 1 and IEC1010 – 2 – 032 concerning safety requirements for electrical measuring instruments and hand – held current clamps with an overvoltage category (CAT II) and pollution 2.

The AC/DC clamp meter complies with the requirements of the following European Community Directives: 89/336/EEC (Electromagnetic Compatibility) and 73/23/EEC (Low Voltage) as amended by 93/68/EEC (CE Marking).

However, electrical noise or intense electromagnetic fields in the vicinity of the equipment may disturb the measurement circuit. Measuring instruments will also respond to unwanted signals that may be present within the measurement circuit.

Users should exercise care and take appropriate precautions to avoid misleading.

Symbol explanation

	Important safety information, refer to the operating manual.
	Dangerous voltage may be present.
	Earth ground.
	Double insulation (Protection class II).
	AC – Alternating Current.
	DC – Direct current.
	Battery.
	Conforms to European Union directives.

Safety precautions

Follow all safety and operating instructions to ensure maximum personal safety during the operation and to ensure the meter is used safely and is kept in good operating condition.

- ⇒ Read these operating instructions thoroughly and completely before operating your meter. Pay particular attention to WARNINGS, which will inform you of potentially dangerous procedures. The instructions in these warnings must be followed.
- ⇒ Always inspect your meter and test leads for any sign of damage or abnormality before every use. If any abnormal conditions exist (i.e. broken test leads, cracked cases, display not reading, etc.), do not attempt to take any measurements.
- ⇒ Do not expose the instrument to direct sunlight, extreme temperature or moisture.
- ⇒ Never ground yourself when taking electrical measurements. Do not touch exposed metal pipes, outlets, fixtures, etc., which might be at ground potential. Keep your body isolated from ground by using dry clothing; rubber shoes, rubber mat, or any approved insulating material.
- ⇒ You always are careful when working with voltages above 60V dc or 30V ac rms. Keep fingers behind the probe barriers while measuring.
- ⇒ Never use the meter to measure voltages that might exceed the maximum allowable input value of any function.

Maintenance

- ⇒ Never touch exposed wiring, connections or any live circuit when attempting to take measurements.
- ⇒ Before opening the case, always disconnect test leads from all energized circuits.
- ⇒ Never use the meter unless the back cover is in place and fastened completely.
- ⇒ Do not use abrasives or solvents on the meter. To clean it using a damp cloth and mild detergent only.
- ⇒ Qualified and trained service technicians should only perform calibration and repair of the meter.
- ⇒ Do not attempt calibration or service unless trained and another person capable of rendering first aid and resuscitation is present.

General description

The meter is an autorange professional AC/DC clamp meter with 3999 counts. For measuring DC and AC voltage, DC and AC current, Resistance, Capacitance, Temperature, Frequency, Duty Cycle, Diode and Continuity Test with battery operated.

Layout(forward)

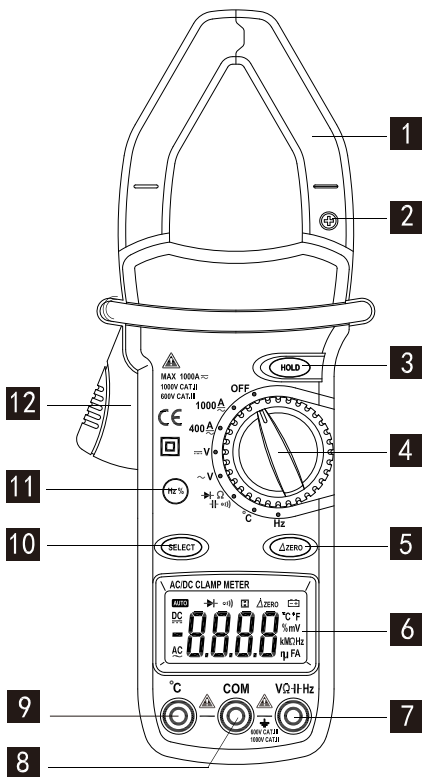

Panel description**1. Transformer jaws**

Pick up the AC or DC current flowing through the conductor.

2. 

DC current direction sign.

3. HOLD button

When this button is pushed, the display will keep the last reading and “” symbol will appear on the LCD. Pushing it again returns the meter to normal mode.

4. Rotary switch

This Rotary switch is used to select functions and power supply of the meter on or off.

5. Δ ZERO button

Push the button to get relative measurement mode, “ Δ ZERO ” annunciate display on LCD. But store the displayed reading as a reference value.

In the Relative mode, the value shown on the LCD is always the difference between the stored reference value and the present reading. If the new reading is the same as the reference value, the display will be zero.

6. LCD display



AUTO

Auto range indication



Diode test indication



Continuity indication



Hold data indication

Δ ZERO

Relative measurement indication



Low battery indication



DC input indication



AC input indication



Polarity indication

%

Duty cycle measurement indication

°C

Temperature (centigrade) measurement

°F

Temperature (fahrenheit) measurement

mV

Voltage measurement unit

kMΩ

Ohm measurement unit

Hz

Frequency measurement unit

μF

Capacitance measurement unit

A

Current measurement unit

Operating instructions

DC voltage measurement

1. Insert the black and red test leads into the **COM** and **VΩHz** input terminals respectively.
2. Set rotary switch at desired V  position.
3. Connect the test lead tips in parallel with the circuit to be measured. Be careful not to touch any electrical conductors.
4. The polarity of the red lead connection will be indicated along with the voltage value.
5. Read the measure result directly from the display.

AC voltage measurement

1. Insert the black and red test leads into the **COM** and **VΩHz** input terminals respectively.
2. Set rotary switch at desired V~ position.
3. Connect the test lead tips in parallel with the circuit to be measured. Be careful not to touch any electrical conductors.
4. Read the AC voltage value from LCD display.
5. When measuring AC voltage, pushing **Hz%** button, the frequency of ACV will show on LCD display.

DC Current measurement

1. Set the rotary switch at desired 400A or 1000A position.
2. Push the SELECT button to select DC current.
3. Push the " ΔZERO " button to get relative measurement mode

and “0000” show on LCD display.

4. Press the trigger to open transformer jaw and to clamp one conductor only, making sure that the jaw is firmly closed around the conductor.
5. Read current value on LCD display.

NOTE:

As the jaw core may remain some magnetic force after using for awhile. If the display can not reach “0”, open the jaws several times. Then work again.

AC current measurement

1. Set the rotary switch at desired 400A or 1000A position.
2. Push the SELECT button to select AC current.
3. Press the trigger to open transformer jaw and to clamp one conductor only, making sure that the jaw is firmly closed around the conductor.
4. Read current value on LCD display.

Resistance measurement

1. Insert the black and red test leads into the **COM** and **VΩ|Hz** input terminals respectively.
2. Set rotary switch at desired **Ω**  **|||** range position.
3. Push SELECT button to select Ω.
4. If the resistance being measured exceeds the maximum value of the range or the input is not connected, an overrange indication



“OL” will be display.

5. Read the measure result directly from LCD display.

NOTE:

1. When checking in-circuit resistance, be sure the circuit under test has all power removed and that all capacitors have been discharged fully.
2. For measuring resistance above $1M\Omega$, the meter may take a few seconds to get stable reading. It is normal for high resistance measurements.
3. When the input is not connected, i.e. at open circuit, the figure “OL” will be displayed for the overrange condition.

Diode test

1. Insert the black and red test leads into the **COM** and **V Ω Hz** input terminals respectively.
2. Set rotary switch at desired **Ω  ** position.
3. Push SELECT button to select ****.
4. The red lead should be connected to the anode and the black lead to the cathode of the diode.
5. The typical voltage drop should be about 0.6V for silicon diode or 0.3V for germanium diode.
6. If the diode is reverse biased or there is an open circuit the reading displayed will be “OL”.

Continuity testing

1. Insert the black and red test leads into the **COM** and **VΩ| Hz** input terminals respectively.
2. Set rotary switch at desired $\Omega \rightarrow \text{+} \text{||} \text{||}$ position.
3. Push SELECT button to select $\text{||} \text{||}$.
4. If continuity exists (i.e., resistance less than 30Ω) built – in buzzer will sound.

Capacitance measurement

1. Insert the black and red test leads into the **COM** and **VΩ| Hz** input terminals respectively.
2. Set the rotary switch to $\Omega \rightarrow \text{+} \text{||} \text{||}$ position.
3. Connect test leads across the capacitor under measurement and be sure that the polarity of connection is observed (Note: The polarity of the red lead connection is positive “+”).
4. Read the measure result directly from the display.

Frequency measurement

1. Insert the black and red test leads into the **COM** and **VΩ| Hz** input terminals respectively.
2. Set rotary switch at desired Hz position.
3. Push Hz% button to select frequency mode and connect the test lead tips in parallel with the circuit to be measured. Be careful not to touch any electrical conductors.
4. The signal amplitude must also be greater than the sensitivity level.

- Determine that the amplitude level of the signal to be measured is not greater than the input voltage limit (250V DC/AC rms.).
- Read the measure result directly from LCD display.

NOTE:

The input voltage should be between 1V and 10V rms. ac. If the voltage is more than 10V rms. Reading may be out of the accuracy range.

Temperature measurement**WARNING**

- ◆ **Before attempting to insert “K” type thermocouple for testing, always be sure that test leads have been disconnected from any measurement circuits.**
- ◆ **“K” type thermocouple should not be connected to the jack when making voltage measurements with test leads.**



- Set the rotary switch at °C Position. The LCD display will show “OL”.
- Connect the red lead of “K” type thermocouple into the “°C ”jack and the black lead of “K” type thermocouple into the “COM” jack. The LCD display will show the current environment temperature.
- Contacting the object be measured with the thermocouple probe.
- Read temperature value on the LCD display.

Duty test

1. Insert the black and red test leads into the **COM** and **V Ω Hz** input terminals respectively.
2. Set rotary switch at desired Hz position.
3. Push Hz% button to select % mode and connect the test lead tips in parallel with the circuit to be measured. Be careful not to touch any electrical conductors.
4. Read the measure result directly from LCD display.

Specifications

General

Maximum voltage	: CAT II 1000V and CAT III 600V.
Display	: LCD 3999 counts. Updates 2-3/sec.
Ranging method	: Auto range mode
Polarity indication	: “-” display for negative polarity.
Overrange indication	: Only figure “OL” on the display.
Jaw capability	: 42mm (Max conductor size)
Power	: Battery 9V  IEC 6F22 JIS 006P NEDA 1604 type.
Low battery	: “  ” appears on the display
Operating	: 5°C to 35°C
Storage temperature	: -10°C to 50°C
Temperature coefficient	: 0.1 × (specified accuracy) / °C (<18°C or >28°C)

Altitude	: 2000m
Size	: 250mm × 99mm × 43mm
Weight	: Appro x. 480g.

Measurement specifications

Accuracy is given as \pm (% of reading + number of least significant digits) at 18°C to 28°C, with relative humidity up to 80%.

All specifications assume less than 1 year since calibration.

DC voltage

Range	Resolution	Accuracy
0.4V	0.1mV	$\pm 0.7\%$ of rdg ± 1 digit
4V	1mV	
40V	10mV	
400V	0.1V	
1000V	1V	$\pm 0.8\%$ of rdg ± 3 digits

Input Impedance: 10M Ω

Overload Protection: 1000V DC or 700V AC RMS

AC voltage

Range	Resolution	Accuracy
4V	1mV	$\pm 0.8\%$ of rdg ± 5 digits
40V	10mV	
400V	0.1V	
700V	1V	$\pm 1.0\%$ of rdg ± 10 digits

Input Impedance: 10M Ω

Frequency range: 40Hz to 400Hz.

Overload Protection: 1000V DC or 700V AC RMS

DC current

Range	Resolution	Accuracy
400A	0.1A	±3.0 % of rdg ± 3 digits
1000A	1A	

Overload Protection:

120% ranges for 60 seconds max.

AC current

Range	Resolution	Accuracy
400A	0.1A	±3.0 % of rdg ± 3 digits
1000A	1A	

Overload Protection:

120% ranges for 60 seconds max.

Frequency range: 50Hz to 60Hz.

Resistance

Range	Resolution	Accuracy
400Ω	0.1Ω	±1.2% of rdg ± 1 digit
4kΩ	1Ω	
40kΩ	10Ω	
400kΩ	0.1kΩ	
4MΩ	1kΩ	
40MΩ	10kΩ	±2.0% of rdg ± 3 digits

Overload Protection: 250V dc or rms. ac for all ranges.

Capacitance

Range	Resolution	Accuracy
4nF	1pF	±4.0% of rdg ± 10 digits
40nF	10pF	
400nF	0.1nF	
4μF	1nF	
40μF	10nF	–

Overload Protection: 250V dc or rms. ac for all ranges.

Frequency



Range	Resolution	Accuracy
40Hz	0.01Hz	±2.0% of rdg ± 1 digit
400Hz	0.1Hz	
4kHz	1Hz	
40kHz	10Hz	
100kHz	0.1kHz	

Measurement range: 1V to 10V rms. 10Hz to 100kHz.

Temperature

Range	Resolution	Accuracy
400°C~750°C	1°C	±1.0% of rdg ± 5 digits
0°C~400°C	1°C	±1.0% of rdg ± 3 digits
-40°C~0°C	1°C	±1.0% of rdg ± 6 digits

Continuity and diode

Range	Description
	If continuity exists (about less than 30Ω), built-in buzzer will sound.
	Show the approx. Forward voltage of the diode.
Duty cycle: 0.1% to 99.9%	

Auto power off

To extend the battery life, Auto Power Off function is provided. If no key operations of range changing happen about 15 minutes, the meter will be turned off automatically. To turn it on, rotate the rotary switch or push any function buttons only.

Replacing the battery

To avoid electrical shock or personal injury, remove the test leads and any input signals before replacing the battery. Replace only with same type of battery.

When the electrical tester displays the “+” mark or the backlight be not very lit, the battery must be replaced to maintain proper operation.

Use the following procedure to replacing the battery:

1. The Rotary Switch is used to select OFF. Disconnect test leads

- from any live source and remove the test leads from the input terminals.
2. Remove screws on the battery cover and open the cover.
 3. Remove the exhausted battery and replace with a new 9-voltage battery (IEC 6F22 JIS 006P NEDA 1604 type).
 4. Never use the multimeter unless the battery cover is in place and fastened fully.

Accessories

- 1 Operator's instruction manual
- 2 Set of test leads
- 3 "K" type thermocouple
- 4 Gift box
- 5 9 volt battery

(IEC 6F22 JIS 006P NEDA 1604 type).

CAUTION:



Using this appliance in an environment with a strong radiated radio – frequency electromagnetic field (approximately 3V/m) may influence its measuring accuracy.