

## 1. Product Description

Nexto Series programmable controllers are the ultimate solution for industrial automation and system control. With high embedded technology, the products of the family are able to control, in a distributed and redundant way, complex industrial systems, machines, high performance production lines and the most advanced processes of Industry 4.0. Modern and high-speed, the Nexto series uses cutting-edge technology to provide reliability and connectivity, helping to increase the productivity of different businesses.

Compact, robust and with high availability, the series products have excellent processing performance and rack expansion possibilities. Its architecture allows easy integration with supervision, control and field networks, in addition to CPU and power supply redundancy. The family's equipment also offers advanced diagnostics and hot swapping, minimizing or eliminating maintenance downtime and ensuring a continuous production process.

With a powerful 64-bit, 1 GHz ARM processor, the CPU NX3008 is ideal for controlling small to large industrial machines and processes. In addition to advanced diagnostics and the diversity of consolidated communication protocols, it has cybersecurity resources, firewall, remote operation and the ability to customize the user's application with the installation of external programs, thanks to the Docker platform and the Linux operating system used on all Nexto Series controllers.



Its main features are:

- Up to 64 Kbytes of %I points and 64 Kbytes of %Q points
- Large memory capacity for user application and user data
- Up to 1 Mbytes of retain or persistent memory
- High-speed ARM 64-bit processing
- 3 Ethernet interfaces 10/100/1000 Mbps
- 1 micro SD card interface
- 1 USB 2.0 host interface
- 1 RS-485 serial interface
- 1 CAN interface with CANopen and J-1939 protocols
- OPC DA/UA, IEC 60870-5-104, PROFINET, EtherCAT, SNMP and EtherNet/IP Protocols
- Support clock synchronization via SNTP or via IEC 60870-5-104
- Web server features
- User web pages (Webvisu)
- Integrated power supply
- One Touch Diag
- IEC 61131-3 compliant
- Real-time clock (RTC)
- Compact and modern design
- Free of moving parts (fans, active cooling, etc.)

## 2. Ordering Information

### 2.1. Included Items

The product package contains the following items:

- NX3008 module
- 6-terminal connector with fixing
- 2x3 connector with fixing

### 2.2. Product Code

The following code should be used to purchase the product:

Code	Description
NX3008	CPU, 3 Ethernet port, 1 USB, 1 serial, 1 CAN, memory card interface, remote rack expansion support, power supply integrated and user web pages support

Table 1: Product Code

## 3. Related Products

The following products must be purchased separately when necessary:

Code	Description
MT8500	MasterTool IEC XE
AL-2600	RS-485 network branch and terminator
AL-2306	RS-485 cable for MODBUS or CAN network
AL-2319	RJ45-RJ45 Cable
NX9101	32 GB microSD memory card with miniSD and SD adapters
NX9202	RJ45-RJ45 2 m Cable
NX9205	RJ45-RJ45 5 m Cable
NX9210	RJ45-RJ45 10 m Cable
NX9000	8-Slot Backplane Rack
NX9001	12-Slot Backplane Rack
NX9002	16-Slot Backplane Rack
NX9003	24-Slot Backplane Rack
NX9010	8-Slot Backplane Rack (No Hot Swap)
NX9020	2-Slot base for panel assembly

Table 2: Related Products

#### Notes:

**MT8500:** MasterTool IEC XE is available in four different versions: LITE, BASIC, PROFESSIONAL and ADVANCED. For more details, please check MasterTool IEC XE User Manual - MU299609.

**AL-2600:** This module is used for branch and termination of RS-422/485 networks. For each network node, an AL-2600 is required. The AL-2600 that is at the ends of network must be configured with termination, except when there is a device with active internal termination, the rest must be configured without termination.

**AL-2306:** Two shielded twisted pairs cable without connectors, used for networks based on RS-485 or CAN.

**AL-2319:** Two RJ45 connectors for programming the CPUs of the Nexto Series and Ethernet point-to-point with another device with Ethernet interface communication.

**NX9202/NX9205/NX9210:** Cables used for Ethernet communication and to interconnect the bus expansion modules.

**NX9020:** 2 slot base for panel assembly.

## 4. Innovative Features

Nexto Series brings to the user many innovations regarding utilization, supervision and system maintenance. These features were developed focusing a new concept in industrial automation.



**VPN:** Nexto products have an embedded VPN service, which creates a private tunnel that connects directly to the CPU. This functionality, available on some models of the family, allows accessing a control network remotely and completely securely..



**FTP:** Supporting FTP-type connections, the series equipment is able to exchange data with a server that uses this same technology model. This functionality allows the files generated by the controller, such as logs collected through a datalogger function, to be accessed remotely.



**Linux:** Another innovative feature of the series is its embedded Linux platform. The feature makes possible the virtualization of software developed for operating systems with Unix technology. The feature gives more versatility and speed to the operation of the system, as it allows the processing of multiple data within the CPU itself.



**Battery Free Operation:** Nexto Series does not require any kind of battery for memory maintenance and real time clock operation. This feature is extremely important because it reduces the system maintenance needs and allows the use in remote locations where maintenance can be difficult to be performed. Besides, this feature is environmentally friendly.



**Easy Plug System:** Nexto Series has an exclusive method to plug and unplug I/O terminal blocks. The terminal blocks can be easily removed with a single movement and with no special tools. In order to plug the terminal block back to the module, the frontal cover assists the installation procedure, fitting the terminal block to the module.



**Multiple Block Storage:** Several kinds of memories are available to the user in Nexto Series CPUs, offering the best option for any user needs. These memories are divided in volatile memories and non-volatile memories. For volatile memories, Nexto Series CPUs offer addressable input (%I), addressable output (%Q), addressable memory (%M), data memory and redundant data memory. For applications that require non-volatile functionality, Nexto Series CPUs bring retain addressable memory (%Q), retain data memory, persistent addressable memory (%Q), persistent data memory, program memory, source code memory, CPU file system (doc, PDF, data) and memory card interface.



**One Touch Diag:** One Touch Diag is an exclusive feature that Nexto Series brings to PLCs. With this new concept, the user can check diagnostic information of any module present in the system directly on CPU's graphic display with one single press in the diagnostic switch of the respective module. OTD is a powerful diagnostic tool that can be used offline (without supervisor or programmer), reducing maintenance and commissioning times.

**OFD – On Board Full Documentation:** Nexto Series CPUs are capable of storing the complete project documentation in its own memory. This feature can be very convenient for backup purposes and maintenance, since the complete information is stored in a single and reliable place.

**ETD – Electronic Tag on Display:** Another exclusive feature that Nexto Series brings to PLCs is the Electronic Tag on Display. This new functionality brings the process of checking the tag names of any I/O pin or module used in the system directly to the CPU's graphic display. Along with this information, the user can check the description, as well. This feature is extremely useful during maintenance and troubleshooting procedures.

**DHW – Double Hardware Width:** Nexto Series modules were designed to save space in user cabinets or machines. For this reason, Nexto Series delivers two different module widths: Double Width (two backplane rack slots are required) and Single Width (only one backplane rack slot is required). This concept allows the use of compact I/O modules with a high-density of I/O points along with complex modules, like CPUs, fieldbus masters and power supply modules.

**High-speed CPU:** All Nexto Series CPUs were designed to provide an outstanding performance to the user, allowing the coverage of a large range of applications requirements.

## 5. Product Features

### 5.1. Common General Features

	<b>NX3008</b>
<b>Backplane rack occupation</b>	2 sequential slots
<b>Power supply integrated</b>	Yes
<b>Ethernet TCP/IP local interface</b>	3
<b>Serial Interface</b>	1
<b>CAN Interface</b>	1
<b>USB Port Host</b>	1
<b>Memory Card Interface</b>	1
<b>Real time clock (RTC)</b>	Yes Resolution of 1 ms and maximum variance of 2 s per day.
<b>Watchdog</b>	Yes
<b>Status and diagnostic Indication</b>	Graphic display LEDs Web pages CPU internal memory
<b>Programming languages</b>	Structured Text (ST) Ladder Diagram (LD) Sequential Function Chart (SFC) Function Block Diagram (FBD) Continuous Function Chart (CFC)
<b>Tasks</b>	Cyclic (periodic) Event (software interruption) External (hardware interruption) Freewheeling (continuous) Status (software interruption)
<b>Online changes</b>	Yes
<b>Maximum number of tasks</b>	24
<b>Maximum number of expansion bus</b>	24
<b>Bus expansion redundancy support</b>	Yes
<b>Maximum number of I/O modules on the bus</b>	128
<b>Maximum number of additional Ethernet TCP/IP interface modules</b>	2
<b>Ethernet TCP/IP interface redundancy support</b>	Yes
<b>Maximum number of PROFIBUS-DP network (using master modules PROFIBUS-DP)</b>	4
<b>PROFIBUS-DP network redundancy support</b>	Yes
<b>Redundancy support (half-clusters)</b>	No
<b>Hot Swap support</b>	Yes
<b>Event oriented data reporting (SOE)</b>	No





	NX3008
<b>Protocol</b>	-
<b>Maximum Event Queue Size</b>	-
<b>User web pages (Webvisu)</b>	Yes
<b>FTP</b>	Yes
<b>Firewall</b>	Yes
<b>VPN</b>	Yes
<b>Docker</b>	TBD
<b>One Touch Diag (OTD)</b>	Yes
<b>Electronic Tag on Display (ETD)</b>	Yes
<b>Standards</b>	
IEC 61131-3	Yes
DNV-GL Type Approval – DNVGL-CG-0339 (TAA000013D)	TBD
IEC 61131-2	Yes
 CE – 2014/35/EU (LVD) and 2014/30/EU (EMC)	TBD
 RoHS – 2011/65/EU	TBD
 LISTED UL/cUL Listed - UL 61010-1 (file TBD)	TBD
 EAC – CU TR 004/2011 (LVD) and CU TR 020/2011 (EMC)	No

Table 3: Common Features

**Notes:**

**Real Time Clock (RTC):** The retention time, time that the real time clock will continue to update the date and time after a CPU power down, is 15 days for operation at 25 °C. At the maximum product temperature, the retention time is reduced to 10 days.

**Maximum number of I/O modules on bus:** The maximum number of I/O modules refers to the sum of all modules on the local bus and expansions.

## 5.2. Memory

	NX3008
<b>Addressable input variables memory (%I)</b>	64 Kbytes
<b>Addressable output variables memory (%Q)</b>	64 Kbytes
<b>Direct representation variable memory (%M)</b>	32 Kbytes
<b>Symbolic variable memory</b>	12 Mbytes
<b>Maximum amount of memory configurable as retentive or persistent</b>	1 Mbytes
<b>Full Redundant Data Memory</b>	-
<b>Direct representation input variable memory (%I)</b>	-
<b>Direct representation output variable memory (%Q)</b>	-

	NX3008
Direct representation variable memory (%M)	-
Symbolic variable memory	-
<b>Total memory</b> Program memory (limited to 32 MBytes) + Source code memory (backup) + Webvisu files memory	256 Mbytes
User files memory	2 Gbytes

Table 4: Memory

### 5.3. Protocols

	NX3008	Interface
Open Protocol	Yes	COM 1 / USB
MODBUS RTU Master	Yes	COM 1
MODBUS RTU Slave	Yes	COM 1
MODBUS TCP Client	Yes	NET 1 / NET 2 / NET 3
MODBUS TCP Server	Yes	NET 1 / NET 2 / NET 3
MODBUS RTU over TCP Client	Yes	NET 1 / NET 2 / NET 3
MODBUS RTU over TCP Server	Yes	NET 1 / NET 2 / NET 3
CANopen Master	Yes	CAN
CANopen Slave	No	-
CAN low level	Yes	CAN
SAE J-1939	Yes	CAN
OPC DA Server	Yes	NET 1 / NET 2 / NET 3
OPC UA Server	Yes	NET 1 / NET 2 / NET 3
EtherCAT Master	Yes	NET 1 / NET 2 / NET 3
SNMP Agent	Yes	NET 1 / NET 2 / NET 3
DNP3 Server (Event-oriented data)	No	-
IEC 60870-5-104 Server	Yes	NET 1 / NET 2 / NET 3
EtherNet/IP Scanner	Yes	NET 1 / NET 2 / NET 3
EtherNet/IP Adapter	Yes	NET 1 / NET 2 / NET 3
MQTT Client	Yes	NET 1 / NET 2 / NET 3 / USB
SNTP Client (for clock synchronism)	Yes	NET 1 / NET 2 / NET 3 / USB
PROFINET Controller	Yes	NET 1 / NET 2 / NET 3
PROFINET Device	No	-
OpenVPN Client	Yes	NET 1 / NET 2 / NET 3
OpenVPN Server	Yes	NET 1 / NET 2 / NET 3

Table 5: Protocols

**Note:**

**USB:** Need to use Serial, WiFi or Modem adapter.

## 5.4. Serial Interface

### 5.4.1. COM 1

COM1	
<b>Connector</b>	Terminal block, D+ and D- with shield
<b>Physical interface</b>	RS-485
<b>Communication direction</b>	RS-485: half duplex
<b>RS-485 maximum transceivers</b>	32
<b>Termination</b>	Yes (optional through parameter)
<b>Cross section</b>	0.5 mm <sup>2</sup>
<b>Baud rate</b>	200, 300, 600, 1200, 1800, 2400, 4800, 9600, 19200, 38400, 57600, 115200 bps
<b>Isolation</b>	
<b>Logic to Serial Port</b>	1000 Vac / 1 minute
<b>Serial Port to protection earth</b> 	TBD

Table 6: COM 1 Serial Interface Features

**Note:**

**RS-485 maximum transceivers:** It is the maximum number of RS-485 interfaces that can be used on the same bus.

## 5.5. CAN Interface

CAN	
<b>Connector</b>	Terminal block, H and L with shield
<b>Physical interface</b>	CAN bus
<b>Supported standards</b>	CAN 2.0A 2.0B (11-bit and 29-bit identifiers)
<b>Max. number of nodes</b>	64
<b>Termination</b>	Yes (Configurable)
<b>Cross section</b>	0.5 mm <sup>2</sup>
<b>Baud rate</b>	10, 20, 50, 100, 125, 250, 500, 800, 1000 kbit/s
<b>Isolation</b>	
<b>Logic to CAN</b>	1000 Vac / 1 minute
<b>CAN to protection earth</b> 	TBD

Table 7: CAN Interface Features

## 5.6. USB Interface

USB	
Connector	USB A Female
Physical interface	USB V2.0
Baud rate	1.5 Mbps (Low-Speed), 12 Mbps (Full-Speed) and 480 Mbps (Hi-Speed)
Maximum current	500 mA
Supported devices	Mass storage USB RS-232 Serial Converter USB 3G/4G Modem USB WiFi Adapter
Isolation	
Logic to USB	Not isolated
USB to protection earth 	TBD

Table 8: USB Interface Features

### 5.6.1. List of Supported Devices

#### 5.6.1.1. RS-232 Converter

Controller	Manufacturer
FT232	FTDI
PL2303	Prolific

Table 9: Supported USB to RS-232 converters

#### 5.6.1.2. 3G/4G Modem

Model	Manufacturer	Type	Remarks
E303	Huawei	Bridge	-
E3276	Huawei	Bridge	-
E8372	Huawei	Router	Redirection of the configuration web page (button <i>Open Modem Configuration</i> ) is not supported for this model. In this case, the modem configuration must be done externally by plugging it directly on a PC.

Table 10: Supported USB modems

### 5.6.1.3. WiFi Adapter

Chipset	Manufacturer	Example of comercial products
RTL8188EU	Realtek	TP-LINK model TL-WN725N LM Technologies model LM007
RT28xx	Ralink/Mediatek	D-Link model DWA-125
AR9271	Atheros/Qualcomm	TP-LINK model TL-WN721N

Table 11: Supported chipsets for USB WiFi adapters

## 5.7. Ethernet Interfaces

### 5.7.1. NET 1

	NET 1
<b>Connector</b>	Shielded female RJ45
<b>Auto crossover</b>	Yes
<b>Maximum cable length</b>	100 m
<b>Cable type</b>	UTP or ScTP, category 5
<b>Baud rate</b>	10/100/1000 Mbps
<b>Physical layer</b>	10BASE-Te/100BASE-TX/1000BASE-T
<b>Data link layer</b>	LLC (Logical Link Control)
<b>Network layer</b>	IP (Internet Protocol)
<b>Transport layer</b>	TCP (Transmission Control Protocol) UDP (User Datagram Protocol)
<b>Diagnostics</b>	LED - green 1000 Mbps (link/activity) LED – yellow 100 Mbps (link/activity) LEDs – green and yellow 10 Mbps (link/activity)
<b>Isolation</b>	
<b>Ethernet interface to logic</b>	1500 Vac / 1 minute
<b>Ethernet interface to Eth-erne interface</b>	1500 Vac / 1 minute
<b>Ethernet interface to pro-tection earth</b> Ⓧ	1500 Vac / 1 minute

Table 12: Ethernet NET 1 Interface Features

The NET 1 Interface is the interface used for programming using the MasterTool IEC XE tool.

### 5.7.2. NET 2

	NET 2
<b>Connector</b>	Shielded female RJ45
<b>Auto crossover</b>	Yes
<b>Maximum cable length</b>	100 m
<b>Cable type</b>	UTP or ScTP, category 5
<b>Baud rate</b>	10/100/1000 Mbps

<b>NET 2</b>	
<b>Physical layer</b>	10BASE-Te/100BASE-TX/1000BASE-T
<b>Data link layer</b>	LLC (Logical Link Control)
<b>Network layer</b>	IP (Internet Protocol)
<b>Transport layer</b>	TCP (Transmission Control Protocol) UDP (User Datagram Protocol)
<b>Diagnostics</b>	LED - green 1000 Mbps (link/activity) LED – yellow 100 Mbps (link/activity) LEDs – green and yellow 10 Mbps (link/activity)
<b>Isolation</b> Ethernet interface to logic Ethernet interface to Eth- erne interface Ethernet interface to pro- tection earth ⊕	1500 Vac / 1 minute 1500 Vac / 1 minute 1500 Vac / 1 minute

Table 13: Ethernet NET 2 Interface Features

### 5.7.3. NET 3

<b>NET 3</b>	
<b>Connector</b>	Shielded female RJ45
<b>Auto crossover</b>	Yes
<b>Maximum cable length</b>	100 m
<b>Cable type</b>	UTP or ScTP, category 5
<b>Baud rate</b>	10/100/1000 Mbps
<b>Physical layer</b>	10BASE-Te/100BASE-TX/1000BASE-T
<b>Data link layer</b>	LLC (Logical Link Control)
<b>Network layer</b>	IP (Internet Protocol)
<b>Transport layer</b>	TCP (Transmission Control Protocol) UDP (User Datagram Protocol)
<b>Diagnstics</b>	LED - green 1000 Mbps (link/activity) LED – yellow 100 Mbps (link/activity) LEDs – green and yellow 10 Mbps (link/activity)
<b>Isolation</b> Ethernet interface to logic Ethernet interface to Eth- erne interface Ethernet interface to pro- tection earth ⊕	1500 Vac / 1 minute 1500 Vac / 1 minute 1500 Vac / 1 minute

Table 14: Ethernet NET 3 Interface Features

## 5.8. Memory Card Interface

The memory card can be used for different data to be stored such as user logs, web pages, project documentation and source files.

Memory Card	
Maximum Capacity	32 Gbytes
Minimum Capacity	2 Gbytes
Type	MicroSD
File System	FAT32
Remove card safely	Yes, through a specific menu for this function.

Table 15: Memory Card Interface Features

**Notes:**

**Maximum Capacity:** The memory card capacity must be less than or equal to this limit for correct operation on Nexto CPU, otherwise the Nexto CPU may not detect the memory card or even present problems during data transfer.

**Minimum Capacity:** The memory card capacity must be greater than or equal to this limit for correct operation on Nexto CPU, otherwise the Nexto CPU may not detect the memory card or even present problems during data transfer.

**File System:** It is recommended to format the memory card using the Nexto CPU, otherwise it may result in performance loss in the memory card interface.

## 5.9. Power Supply

Nominal input voltage	24 Vdc
Maximum output power	15 W
Maximum output current	3 A
Input voltage	18 to 30 Vdc
Maximum input current (in-rush)	50 A
Maximum input current	TBD
Maximum input voltage interruption	10 ms @ 24 Vdc
Isolation	
Input to logic	1000 Vac / 1 minute
Input to protective earth 	1000 Vac / 1 minute
Cross section	0.5 mm <sup>2</sup>
Polarity inversion protection	Yes
Internal fuse	Yes
Output short-circuit protection	No
Overcurrent protection	No

Table 16: Power Supply Features

## 5.10. Environmental Characteristics

Current consumption on the power supply rail	-
Dissipation	TBD
Operating temperature	-20 to 60 °C
Storage temperature	-40 to 75 °C
Relative humidity	5% to 96%, non-condensing
Conformal coating	Yes
IP Level	IP 20
Module dimensions (W x H x D)	36,00 x 114,63 x 115,30 mm
Package dimensions (W x H x D)	44,00 x 122,00 x 147,00 mm
Weight	330 g
Weight with package	380 g

Table 17: Environmental Characteristics

**Note:**

**Conformal coating of electronic circuits:** The covering of electronic circuits protects internal parts of the product against moisture, dust and other harsh elements to electronic circuits.

## 5.11. Performance

Instruction	Language	Variables	Instruction Times ( $\mu$ s)
1000 Contacts	LD	BOOL	2,1
1000 Divisions	ST	INT	9,2
		REAL	17,0
	LD	INT	9,2
		REAL	17,0
1000 Multiplications	ST	INT	6,4
		REAL	8,2
	LD	INT	6,4
		REAL	8,2
1000 Sums	ST	INT	4,4
		REAL	8,2
	LD	INT	4,4
		REAL	8,2
1000 PID	ST	REAL	< 460

Table 18: Instruction Times

## 6. Compatibility with Other Products

To develop an application for Nexto Series CPUs, it is necessary to check the version of MasterTool IEC XE. The following table shows the minimum version required (where the controllers were introduced) and the respective firmware version at that time:

Nexto Series CPUs	MasterTool IEC XE	Firmware version
NX3008	3.40 or above	1.10.0.0 or above

Table 19: Compatibility with other products

Additionally, along the development roadmap of MasterTool IEC XE some features may be included (like special Function Blocks, etc...), which can introduce a requirement of minimum firmware version. During the download of the application, MasterTool IEC XE checks the firmware version installed on the controller and, if it does not meet the minimum requirement, will show a message requesting to update. The latest firmware version can be downloaded from Altus website, and it is fully compatible with previous applications.

## 7. Physical Dimensions

Dimensions in mm.

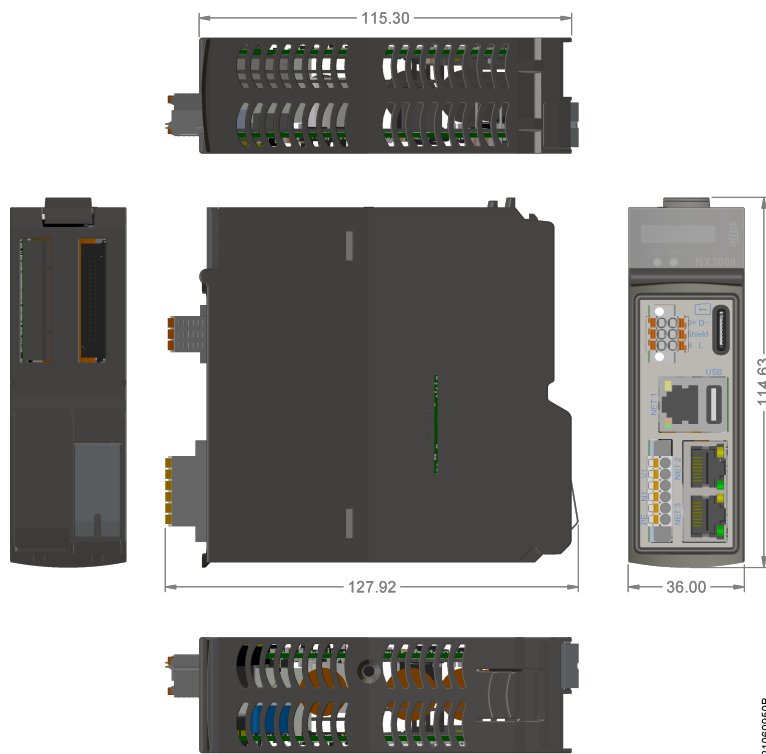

Figure 1: Dimensions in mm.

## 8. Installation

For the correct installation of this product, it is necessary to use a rack (backplane rack) and it must be carried out according to the mechanical and electrical installation instructions that follow.

### 8.1. Product Identification

This product has some parts that must be observed before installation and use. The following figure identifies each of these parts.

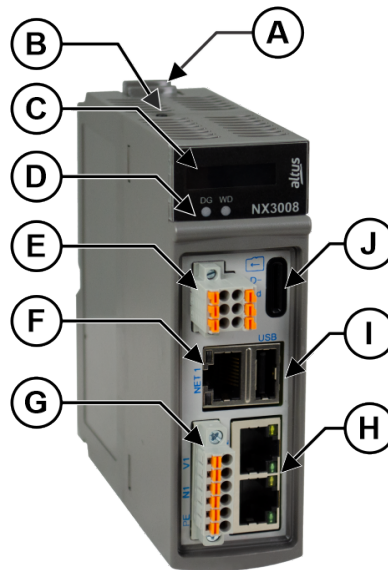

Figure 2: NX3008

- Ⓐ Fixing lock.
- Ⓑ Diagnostic switch.
- Ⓒ Status and diagnostic display.
- Ⓓ Diagnostic and watchdog LEDs.
- Ⓔ Connector for RS-485 and CAN communication.
- Ⓕ RJ45 connector for Ethernet communication.
- Ⓖ Connector for power supply.
- Ⓗ RJ45 connectors for Ethernet communication.
- Ⓘ USB 2.0 connector.
- ⓵ MicroSD card connector.

The product has in its mechanics a label that identifies it and in it are presented some symbols whose meaning is described below:

⚠ Attention! Before using the equipment and installing, read the documentation.

⎓ Direct Current.

## 8.2. Electrical Installation

The figure below shows the CPU NX3008 electric diagram installed in a Nexto Series backplane rack. The connectors placement depicted are merely illustrative.

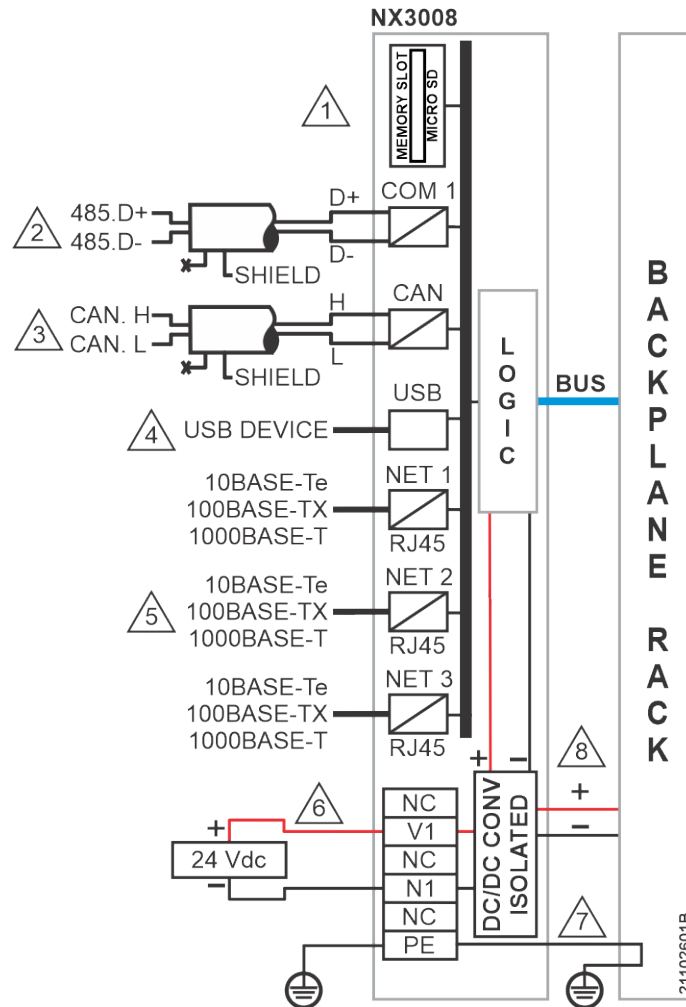











Figure 3: NX3008 CPU Electric Diagram

**Diagram Notes:**

-  MicroSD card interface.
-  RS-485 interface.
-  CAN interface.
-  USB 2.0 interface.
-  Ethernet 10BASE-T<sub>e</sub>/100BASE-TX/1000BASE-T standard interface.
-  The power supply is connected to terminals V1 and N1. Use 0.5 mm<sup>2</sup> cable.
-  The CPU is grounded through the Nexto Series backplane racks. It is recommended to reinforce the ground connecting to the PE terminal. Use 0.5 mm<sup>2</sup> cable.
-  The CPU supplies the other modules through the connection to the backplane rack.
-  Functional earth terminal.

### 8.3. Mechanical Assembly

This product must be inserted in the backplane rack position 0. It requires two sequential positions, this means that it uses positions 0 and 1 of the rack.

The mechanical assembly of this module is described in the NX3008 CPU User Manual – MU214620.

**ATTENTION**

Products with broken warranty seal are not covered in warranty.

**CAUTION**



The device is sensitive to static electricity (ESD). Always touch in a metallic grounded object before handling it.

**DANGER**



Nexto Series can operate with voltage up to 250 Vac. Special care must be taken during the installation, which should only be done by qualified technical personnel. Do not touch on the wiring field when in operation.

## 9. Manuals

For further technical details, configuration, installation and programming of Nexto Series the table below should be consulted.

The table below is only a guide of some relevant documents that can be useful during the use, maintenance, and programming of this product.

Code	Description	Language
<b>CE114000</b>	Nexto Series – Technical Characteristics	English
<b>CT114000</b>	Série Nexto – Características Técnicas	Portuguese
<b>CS114000</b>	Serie Nexto – Características Técnicas	Spanish
<b>CE114109</b>	NX3008 Technical Characteristics	English
<b>CT114109</b>	Características Técnicas NX3008	Portuguese
<b>CS114109</b>	Especificaciones y Configuraciones NX3008	Spanish
<b>CE114700</b>	Nexto Series Backplane Racks Technical Characteristic	English
<b>CT114700</b>	Características Técnicas dos Bastidores da Série Nexto	Portuguese
<b>CS114700</b>	Características Técnicas de los Bastidores de la Serie Nexto	Spanish
<b>CE114810</b>	Nexto Series Accessories for Backplane Rack Technical Characteristics	English
<b>CT114810</b>	Características Técnicas Acessórios para Bastidor Série Nexto	Portuguese
<b>CS114810</b>	Características Técnicas del Cierres Laterales para el Bastidor	Spanish
<b>CE114902</b>	Nexto Series PROFIBUS-DP Master Technical Characteristics	English
<b>CT114902</b>	Características Técnicas do Mestre PROFIBUS-DP da Série Nexto	Portuguese
<b>CS114902</b>	Características Técnicas del Módulo Profibus-DP Maestro	Spanish
<b>CE114908</b>	NX5110 and NX5210 PROFIBUS-DP Heads Technical Characteristics	English
<b>CT114908</b>	Características Técnicas Interfaces Cabeça PROFIBUSDP NX5110 e NX5210	Portuguese
<b>CS114908</b>	Especificaciones y Configuraciones PROFIBUS-DP Interfaz Cabezas NX5110 y NX5210	Spanish
<b>MU214600</b>	Nexto Series User Manual	English
<b>MU214000</b>	Manual de Utilização Série Nexto	Portuguese
<b>MU214620</b>	NX3008 CPU User Manual	English
<b>MU214109</b>	Manual de Utilização UCP NX3008	Portuguese
<b>MU299609</b>	MasterTool IEC XE User Manual	English
<b>MU299048</b>	Manual de Utilização MasterTool IEC XE	Portuguese
<b>MP399609</b>	MasterTool IEC XE Programming Manual	English
<b>MP399048</b>	Manual de Programação MasterTool IEC XE	Portuguese
<b>MU214601</b>	NX5001 PROFIBUS DP Master User Manual	English
<b>MU214001</b>	Manual de Utilização Mestre PROFIBUS-DP NX5001	Portuguese
<b>MU214608</b>	Nexto PROFIBUS-DP Head Utilization Manual	English
<b>MU214108</b>	Manual de Utilização da Cabeça PROFIBUS-DP Nexto	Portuguese
<b>MU214603</b>	Nexto Series HART Manual	English
<b>MU214610</b>	Advanced Control Functions User Manual	English
<b>NAP151</b>	Utilização do Tunneller OPC	Portuguese
<b>NAP165</b>	Comunicação OPC UA com Controladores ALTUS	Portuguese
<b>NAP165_ing</b>	OPC UA Communication with ALTUS Controllers	English

Table 20: Related documents