

**PRODUCT DESCRIPTION:**

**SPH1\_UB**

**PRODUCT CODE:**

**SPH1X22C020UB**

**DYNAMIC 3D VIEW:**

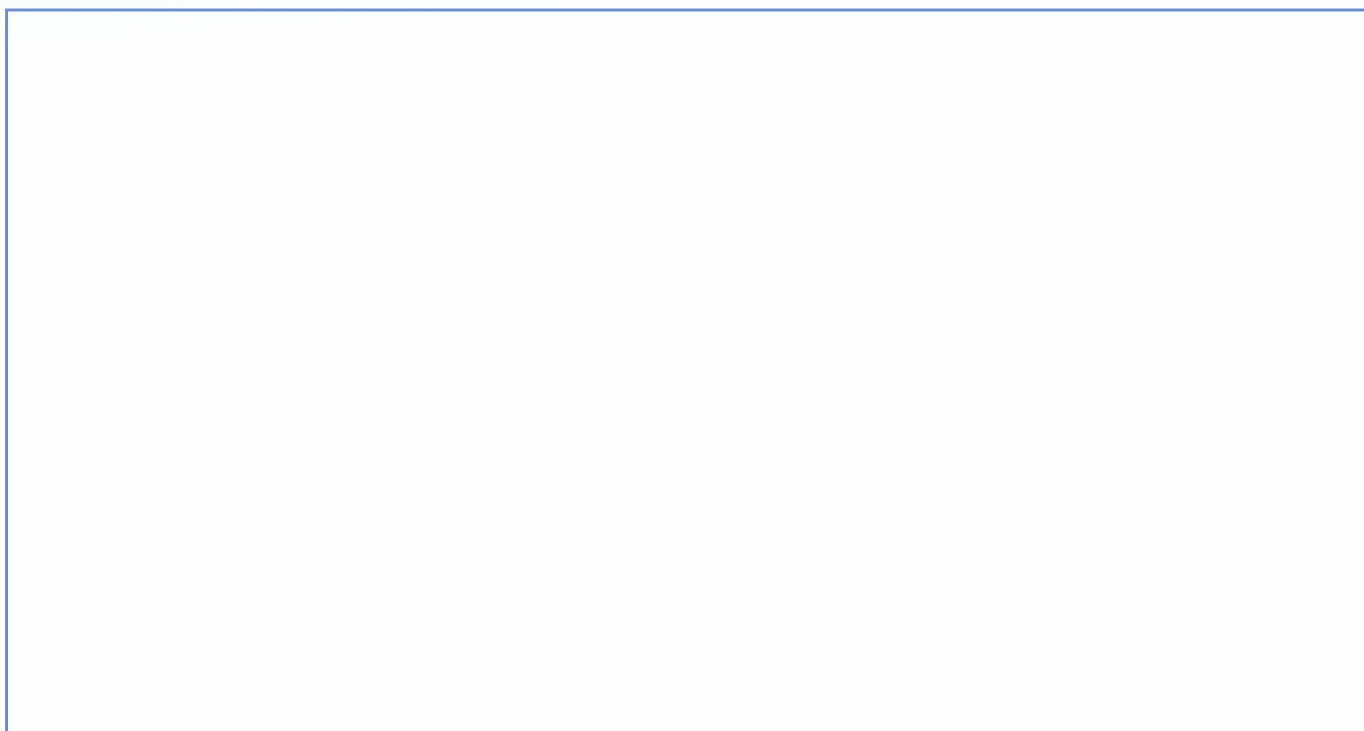

**STATIC 3D VIEW:**

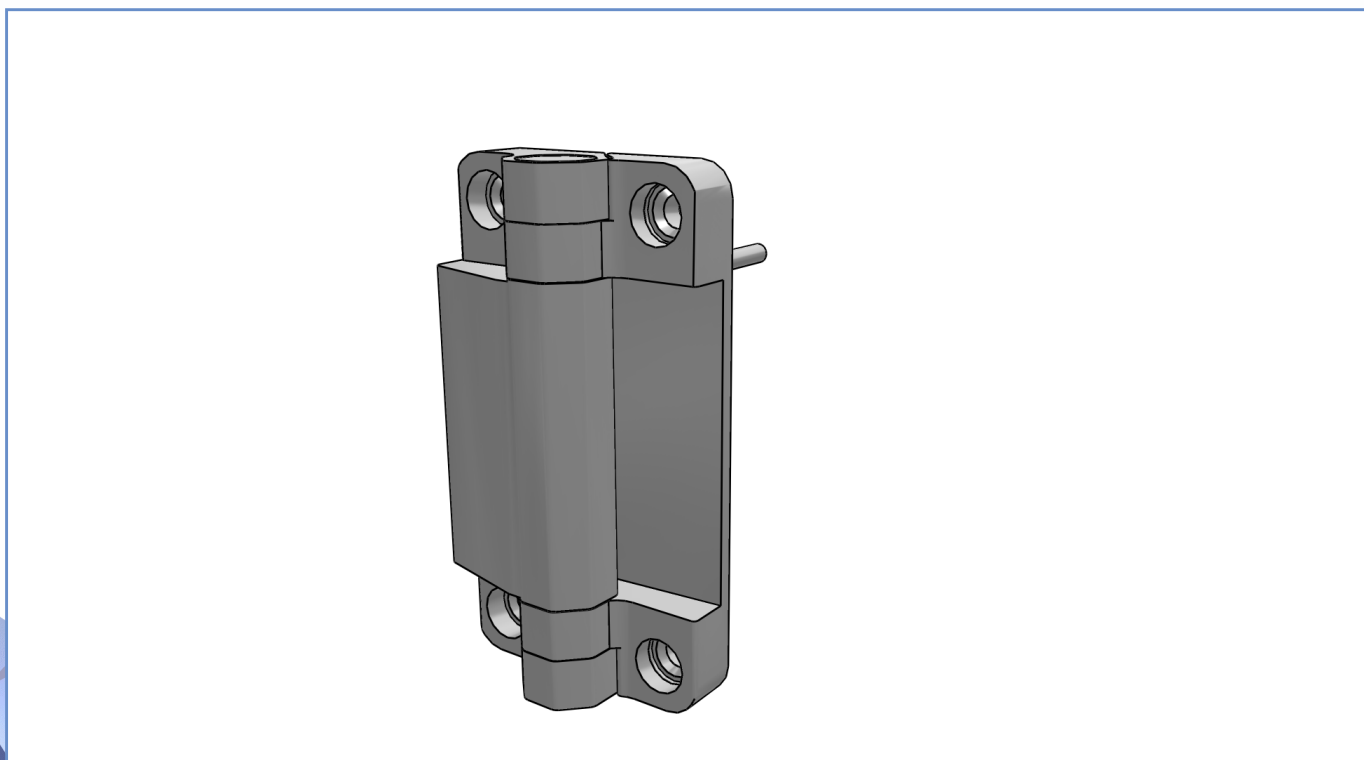

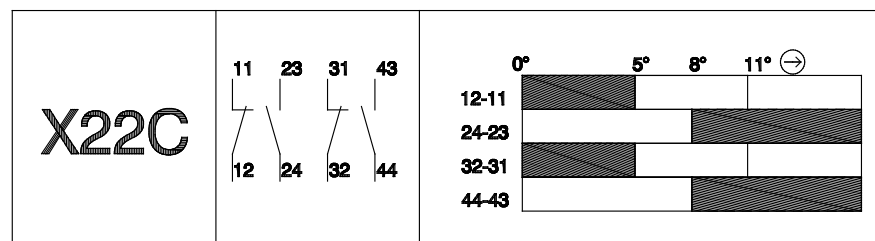
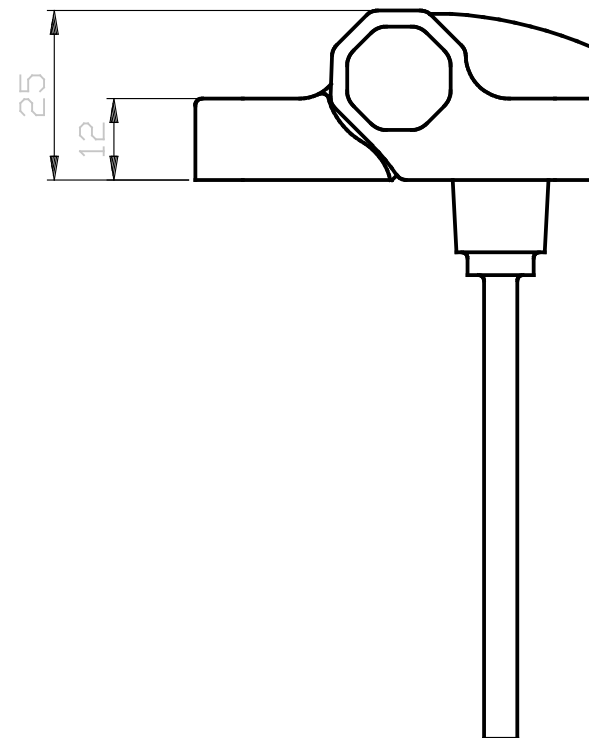
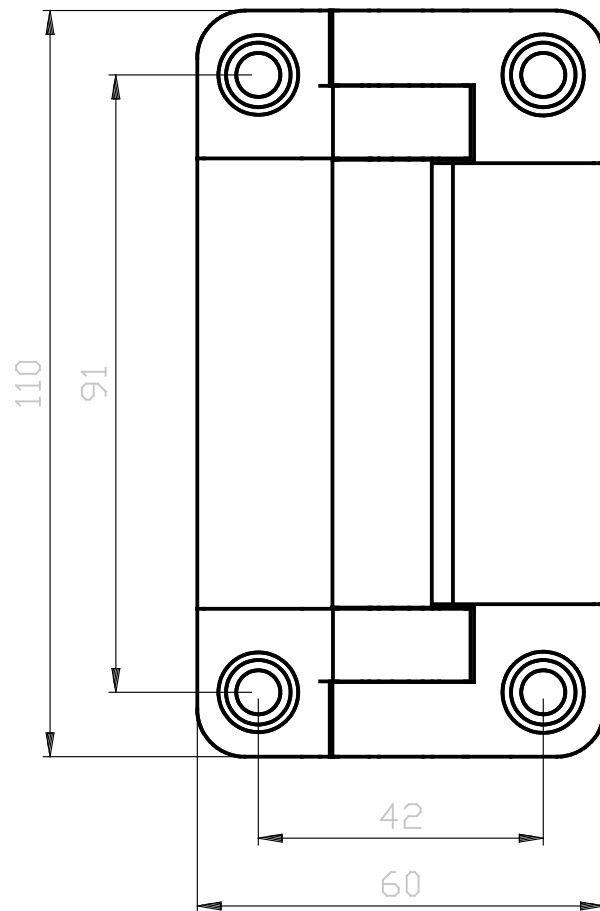
**TECHNICAL VIEW:**

**DETAILS:**

Part Number	SPH1X22C020UB
Casing Material	Reinforced thermoplastic
Width [mm]	110
Electrical connections	Prewired with PVC UL cable 8x0.34 - length 2m
IP Degree of Protection	IP67
Actuating Head	/
Head Material	/
Microswitch	Non-overlapping slow action contacts ( 2NO + 2NC )
Approvals	IMQ - cULus - CCC - EAC
Reference Directives	2014/35/UE - 2006/42/CE
Reference Standards	IEC 60947-5-1 / EN 60947-5-1 / EN ISO 14119
Interlock type according to EN ISO 14119	Type 1
Operating Temperatures [°C]	-20°C ... +80°C
Stock Temperatures [°C]	-20°C ... +80°C
Protection against electric shocks (according to IEC 60536) [Class]	Class II - Double insulation
Rated Insulating Voltage Ui [V]	400
Pollution Degree	3
Contact rating secondo UL50	C300 - Q300
Rated Impulsive Voltage Uimp [kV]	4
Conventional thermal current in air free Ith (θ)	4
Short circuit protection (EU)	4
Operating currents Ie - AC-15 (50-60 Hz) according to IEC 60947-5-1	24V - 4A / 120V - 4A / 400V - 4A
DC-13 operating currents according to IEC 60947-5-1	24V - 2A / 125V - 0.4A / 250V - 0.3A
Switching Frequency [cycles/hour]	1200
Resistance Between Contacts [mΩ]	/
Connecting Terminals	PVC cable 8x0.34
Connecting Cables Dimensions [mm <sup>2</sup> ]	0.34
Marking Terminals	/
Connection scheme	NO: Green/White - NO: Yellow/Blue - NC: Red/Pink - NC: Brown/Grey
Mechanical Durability [Millions of Operations]	1

**PRODUCT DRAWING RELEASE:**

Datasheet creation date: 24/09/2020 16:40

Last Modification (geometry): 13/08/2020 09:14



**DETAILS:**

<b>B10d [Millions of Operations]</b>	<b>2</b>
<b>Related Products</b>	<b>M OSSD, MS1, ECS</b>

**PRODUCT DRAWING RELEASE:**

Datasheet creation date: 24/09/2020 16:40

Last Modification (geometry): 13/08/2020 09:14

tel. +39 039 9906408  
+39 039 9903468  
fax +39 039 9906203Via Novarino 9/L  
23899 Robbiate (LC)  
ITALY[www.comepi.it](http://www.comepi.it)  
[comepi@comepi.it](mailto:comepi@comepi.it)  
[tecnico@comepi.it](mailto:tecnico@comepi.it)