

Product Description

Nexto Series is a powerful and complete Programmable Logic Controller (PLC) with unique and innovative features. Due to its flexibility, smart design, enhanced diagnostics capabilities and modular architecture, Nexto Series can be used for control systems from medium to high-end large applications. Due to its compact size, high density of points per module and superior performance capacity, Nexto can also be used for small automation systems with high performance requirements, as industrial machinery and manufacture applications.

Bus technology used in the series is based on high speed deterministic Ethernet which allows the inputs, outputs and processed information to be shared among modules of the system. The I/O modules can be easily distributed in the field and can be used for both local I/O (located at the same rack of CPU module) and as remote without any loss in performance through the NX4000 bus expansion module.

Besides allowing the bus expansion without loss of performance, the module NX4000 allows the use of two kinds of redundancy, characteristic which increases I/O system availability.



Its main features are:

- Bus expansion with loopback support (cable redundancy)
- Bus expansion module redundancy support
- One Touch Diag
- Electronic Tag on Display
- Display for diagnostics indication

Ordering Information

Included Items

The product package contains the following items:

- NX4000 module
- Installation guide

Product Code

The following codes should be used to purchase the product:

Code	Description
NX4000	Bus Expansion Module

Related Products

The following products must be purchased separately when necessary:

Code	Description
NX9202	RJ45-RJ45 2 m Cable
NX9205	RJ45-RJ45 5 m Cable
NX9210	RJ45-RJ45 10 m Cable

Note:

NX9202, NX9205 and NX9210: These cables that may be used to interconnect the bus expansion modules are available in lengths described in the table above.

Innovative Features

Nexto Series brings to the user several innovations in utilization, supervision and system maintenance. These features were developed focusing a new experience in industrial automation. The list below shows some new features that the user will find in NX4000 module:



One Touch Diag: One Touch Diag is a feature that Nexto Series brings to PLCs. With this new concept, the user can check diagnostic information of any module present in the system directly on CPU's graphic display with one single press in the diagnostic switch of the respective module. OTD is a powerful diagnostic tool that can be used offline (without supervisor or programmer), reducing maintenance and commissioning times.

ETD – Electronic Tag on Display: Another feature that Nexto Series brings to PLCs is the Electronic Tag on Display. This new functionality makes the process of checking the tag names of any I/O terminal or module used in the system directly on the CPU's graphic display. Along with this information, the user can check the description, as well. This feature is extremely useful during maintenance and troubleshooting procedures.







DHW – Double Hardware Width: Nexto Series modules were designed to save space in user cabinets or machines. For this reason, Nexto Series delivers two different module widths: Double Width (two backplane rack slots are required) and Single Width (only one backplane rack slot is required). This concept allows the use of compact I/O modules with a high-density of I/O points along with complex modules, like CPUs, fieldbus masters and power supply modules.



iF Product Design Award 2012: Nexto Series was the winner of iF Product Design Award 2012 in industry + skilled trades group. This award is recognized internationally as a seal of quality and excellence, considered the Oscars of the design in Europe.

Product Features

General Features

	NX4000
Backplane rack occupation	2 sequential slots
Support bus expansion with loopback (redundant cabling)	Yes
Redundancy support of bus expansion	Yes
Maximum number of expansion racks	NX3004: 1 rack NX3005: 4 racks NX3010: 8 racks NX3020: 24 racks NX3030: 24 racks
Maximum number of I/O modules	128
Hot swap support	Yes
Status and diagnostic indication	Display, web page and CPU's internal memory
One Touch Diag (OTD)	Yes
Electronic Tag on Display (ETD)	Yes
Isolation	
Logic to bus expansion interfaces	1500 Vac/1 minute
Logic to protective earth 	1250 Vac/1 minute
Bus expansion interfaces to protective earth 	1250 Vac/1 minute
Current consumption from backplane rack power supply	360 mA
Dissipation	1,8 W
IP Level	IP 20
Operating temperature	0 to 60 °C
Storage temperature	-25 to 75 °C
Operating and storage relative humidity	5 to 96 %, no condensing
Conformal coating	Yes
Standards	IEC 61131-2 CE – 2011/65/EU (RoHS), 2014/35/EU (LVD) and 2014/30/EU (EMC) UL Listed - UL61010-1 (file E473496) DNV-GL Type Approval – DNVGL-CG-0339 (TAA000013D) EAC - CU TR 004/2011 (LVD) and CU TR 020/2011 (EMC)    
Module dimensions (W x H x D)	36.00 x 114.63 x 117.07 mm
Package dimensions (W x H x D)	42.00 x 122.00 x 147.00 mm
Weight	200 g
Weight with package	250 g

Notes:

Maximum number of expansion racks: This number represents only the amount of expansion racks, not being counted the local rack where the CPU of the system is located.

Status and diagnostic indication: More information about diagnostic and status indication can be found on the topic Maintenance.

Logic: Logic is the name for the internal interfaces like processors, memories and backplane rack interfaces.

Conformal coating: Conformal coating protects the electronic components inside the product from moisture, dust and other harsh elements to electronic circuits.

System Configurations

Suggested configurations using NX4000 are shown below:

Configuration A: Bus Expansion without Loopback

These architectures are based on a base rack (where the CPU is placed) and remote racks. The communication between the base rack and the remote racks is done via NX4000 modules.

Each remote rack needs its own power supply module and a Bus Expansion module. The Bus Expansions has two RJ45 ports, where one port is for incoming data and another one for outgoing data.

In this application example, only the NX4000 local module outgoing port is connected. The incoming data port open. The last remote rack has the outgoing data port open. The remote racks in between, will have both ports connected: one port connected to previous rack and the other to the next rack. Each Bus Expansion has a switch for selecting the rack address.

This architecture is intended for medium to large applications, where the number of I/O points is high.

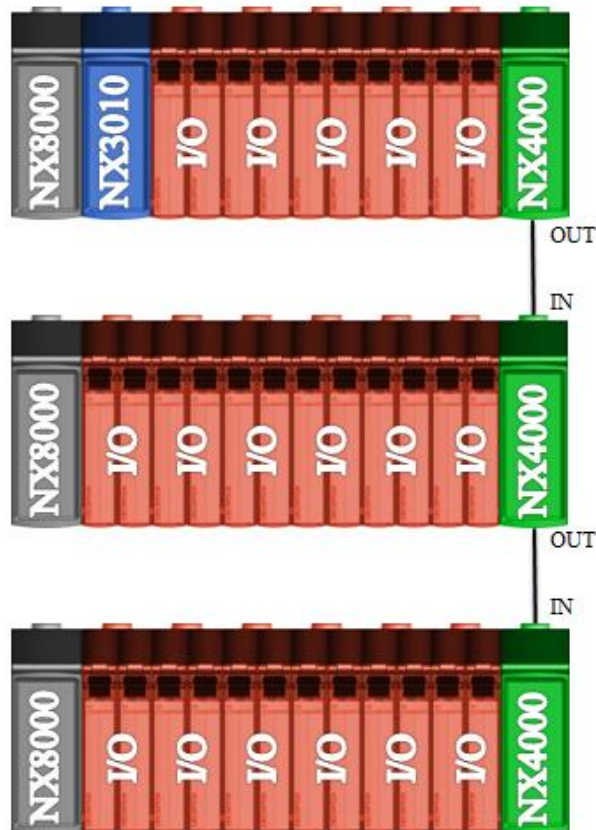

ATTENTION:

This module executes the bus expansion function, because it, can not install additional and non-declared NX4000 modules on the bus.

Configuration B: Bus Expansion with Loopback

This architecture is based on the previous one with a base rack (where the CPU is placed) and remote racks. The communication between the base rack and remote racks is done via the Bus Expansion modules. The only difference is that the outgoing data port in the last NX4000 module is connected to the NX4000 base rack incoming data port. This architecture allows the system to keep the I/O access even in the case of a single failure on extension cables. The CPU will detect the damaged cable, re-route the internal data paths to override this failure and generate user diagnostics. This feature is interesting for fast maintenance with the system powered on and it increases the overall system availability.

This architecture is intended for medium to large applications, where the number of I/O points is high and there is the need of higher availability.

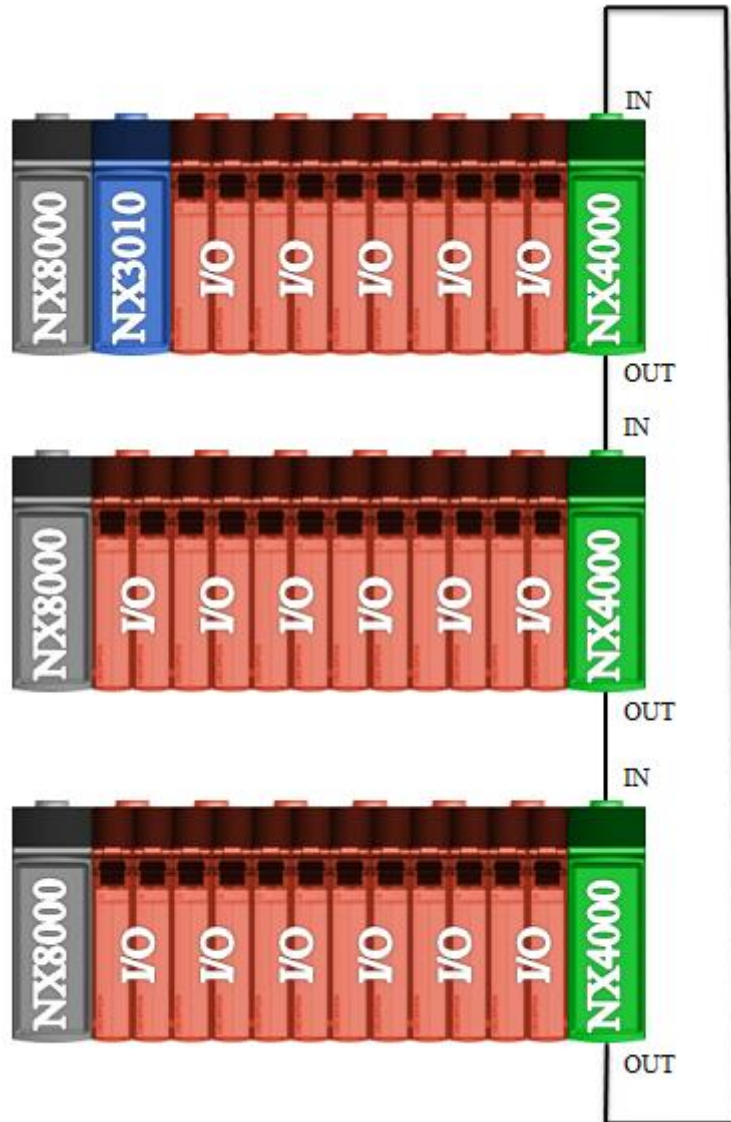

ATTENTION:

This module executes the bus expansion function, because it, can not install additional and non-declared NX4000 modules on the bus.

Configuration C: Bus Expansion Redundant with Loopback

This architecture is based on using two modules NX4000 per rack. With two bus expansion modules, the system has a high availability because supports fault in the NX4000 module or in a cable.

As the previous architecture, this architecture is intended to systems where the maintenance system is critical and must be available for long periods. In this architecture, the racks must be mounted according to the diagram below, with modules NX4000 located side by side in the last positions.

Note that there are ports for bus expansion modules not used, which should be left disconnected.

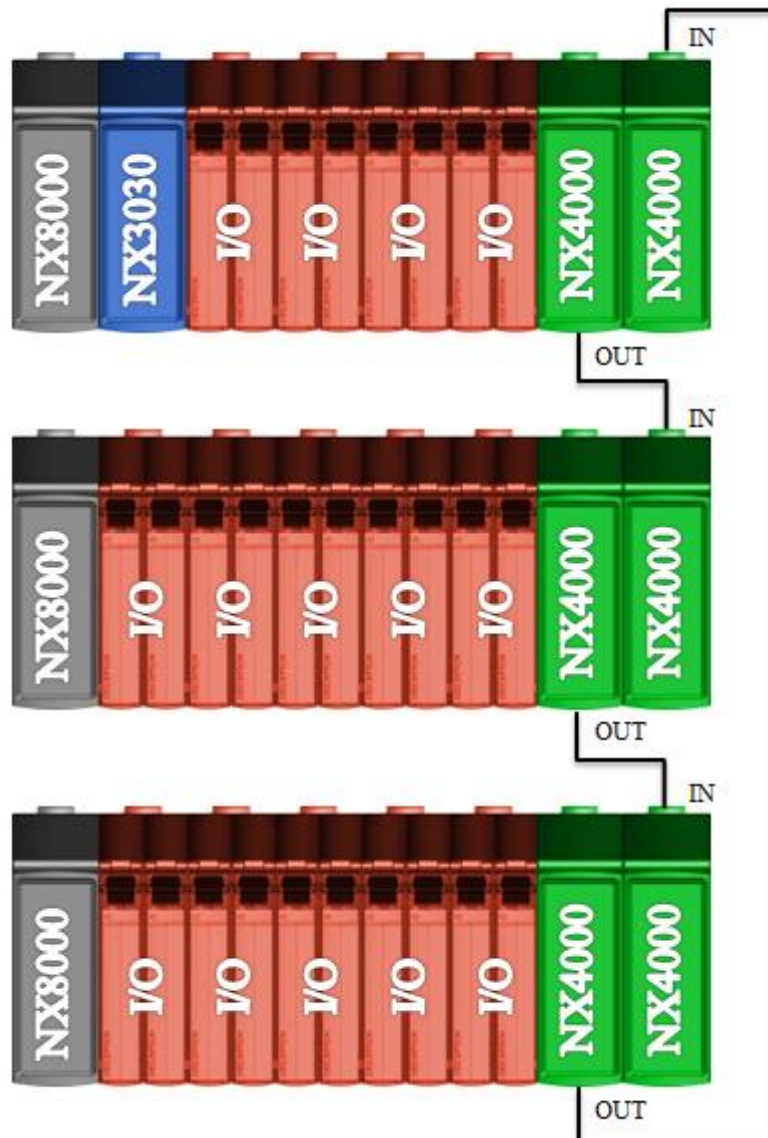

ATTENTION:

This module executes the bus expansion function, because it, can not install additional and non-declared NX4000 modules on the bus.

Compatibility with Other Products

All Nexto series CPUs allow support of bus expansion, performed by NX4000 module.

The interface modules with networks fields such as NX5000, NX5001 and NX4010 can not be installed on expansion bus. They can only be installed on the main bus, along with the CPU.

According to the System Configurations section, expanding bus with the NX4000 can be configured in three different ways: without loopback, with loopback and redundancy of the NX4000 with loopback. The configuration with redundancy is only available from the review of AD NX4000 (version 1.1.0.0 or higher).

The following table provides information regarding the compatibility of the module NX4000, models CPUs and Nexto Series programming tool MasterTool IEC XE.

NX4000		Software Version Compatible	
Version	Revision	UCPs Série Nexto	MasterTool IEC XE
1.0.0.1	up to AC	1.2.0.5 or higher	1.25 or higher
1.1.0.0 or higher	AD or higher	1.2.0.5 or higher	1.29 or higher

Note:

Revision: If the software is upgraded in the field the product reviewing indicated on the label will no longer match the actual review of the product.

Physical Dimensions

Dimensions in mm.

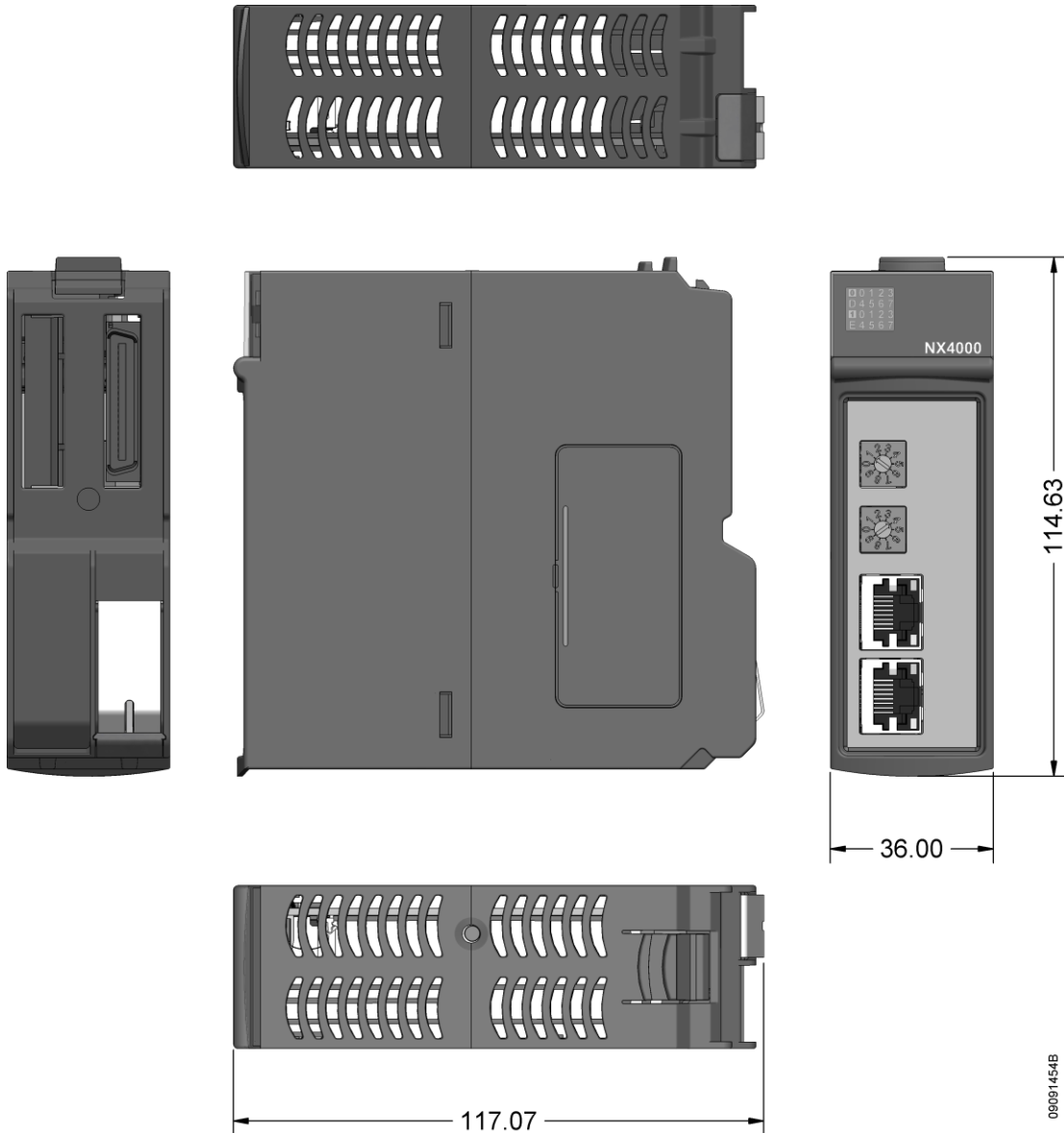

Installation

Electrical Installation

The module NX4000 must be placed in the last two positions of the rack. When using bus expansion module redundancy, both modules must be positioned in the last four positions of the rack. The figure below demonstrates the connection diagram of each bus expansion module.

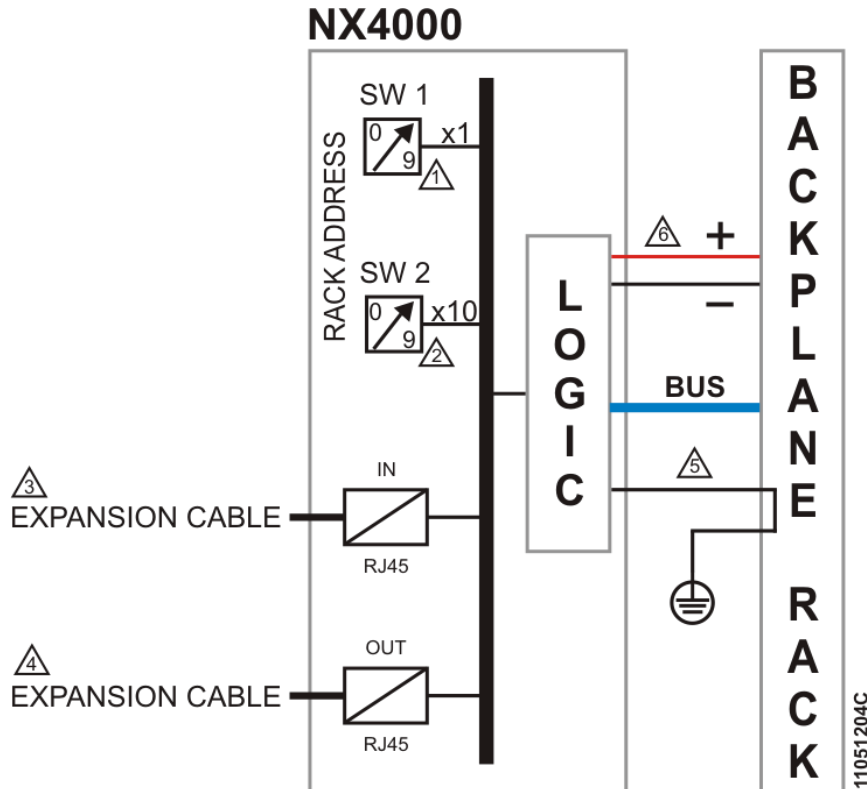

Diagram Notes:

1 , 2 - The address of the remote rack is defined by SW1 and SW2 switches so that the unit is set in the key SW1 and the decade is set in the switch SW2. As an example, the rack with address "15" must have "5" in SW1 and "1" in SW2.

3 - Bus expansion interface IN. When used, must be connected to another rack expansion interface OUT.

4 - Bus expansion interface OUT. When used, must be connected to another rack expansion interface IN.

5 - The module is grounded through the Nexto Series backplane racks.

6 - The module is powered through the connection with the rack.

ATTENTION:

Bus expansion interfaces IN and OUT must be connected only to other bus expansion modules (NX4000) and/or converters for optical fiber network. The connection of these interfaces in switches or other equipment may result in system malfunction.

Mechanical Assembly

Information and orientations about correct mechanical installation can be found at Nexto Series User Manual - MU214600.

Configuration

The Nexto Series CPUs User Manual - MU214605 should be consulted for information on module configuration.

Process Data

The process data, when available, are the variables used for access and module control. The table below shows all the variables delivered by NX4000.

Process Data	Description	Type	Update
Reserved	Reserved	%IB (Read)	Always

Note:

Update: The field Update indicates if the respective process data is updated by CPU and NX4000. When it is set as Always, it means that the process data is always updated.

Module Parameters

Name	Description	Standard Value
Rack number	Sets rack number	0
Expansion cable type	Expansion cable type connected to port IN of NX4000 module	NOT_CONNECTED
%Q Start Address of Module Diagnostics	Defines the start address of the module diagnostics.	-

Notes:

Standard value: MasterTool IEC XE programmer fills it automatically, but allows the user to edit its initial offset. The limit depends on the CPU supported model (details at CPUs Nexto Series User Manual – MU214605).

Expansion cable type: Presents cable options that can be connected to the IN port, cables NX9202, NX9205 and NX9210 are described in the section Related Products. The CUSTOM CABLE option now includes the option of using a standard ETHERNET cable (100 BASE TX) maximum length 100 meters, not provided by Altus.

Maintenance

Altus recommends that all modules' connections must be checked and that all dust or any kind of dirt located at the module's enclosure must be removed at least every 6 months.

NX4000 offers five important features to assist the user during maintenance: Electronic Tag on Display, One Touch Diag, Status and Diagnostics Indicators, Web Page with Complete Status and Diagnostics List and Diagnostics Mapped through Variables.





Electronic Tag on Display e One Touch Diag

Electronic Tag on Display and One Touch Diag are important features that provides to the user the chance to check the tag, description and diagnostics related to a given module directly on the CPU display.

To check the module tag and diagnostics of a given module, it's required only one short press on its diagnostic switch. After press once, CPU will start to scroll tag information and diagnostic information of the module. To access the respective description for the module just long press the diagnostic switch of the respective module.

More information about Electronic Tag on Display can be found at Nexto Series CPUs User Manual – MU214605.

Status and Diagnostic Indicators

All Nexto Series slave modules have a display with the following symbols: D, E,   and numeral characters. The states of the symbols D, E,   are common for all Nexto Series slave modules. These states can be consulted in the table below.

The meaning of the numerical characters can be different for specific modules. NX4000 doesn't use these segments.

D and E States

D	E	Description	Cause	Solution	Priority
Off	Off	Display fail or module off	Disconnected module. No external supply or hardware fail	Check if the module is completely connected to the backplane rack and if the backplane rack is supplied by an external power supply	-
On	Off	Normal use	-	-	9 (lower)
Blinking 1x	Off	Active Diagnostics	There is at least one active diagnostic related to the module NX4000	Check the active diagnostic	8
Blinking 2x	Off	CPU in STOP mode	CPU in STOP mode	Check if CPU is in RUN mode. More information can be found on CPU's documentation	7
Blinking 3x	Off	Reserved	-	-	6
Blinking 4x	Off	Non-fatal fault	Failure in some hardware or software component, which does not have impact on the basic functionality of the product	Check the module diagnostic information. If it is a hardware fault, provide the replacement of this part. If it is a software fault, please contact the Technical Support	5
Off	Blinking 1x	Parameterization error	-	Check if the module parameterization is correct	4
Off	Blinking 2x	Loss of master	Loss of communication between module and CPU	Check if the module is completely connected to the backplane rack Check if CPU is in RUN mode	3
Off	Blinking 3x	Reserved	-	-	2
Off	Blinking 4x	Hardware fatal fault	Hardware fault	Contact Altus Technical Support in case of fatal hardware error	1 (higher)

0, 1 and Numeral Characters

The segments 0 and 1 should be normally off. These two segments will start to blink when the module is on the Diagnostic Mode (Electronic Tag on Display and One Touch Diag).

The Numeral characters aren't used in this module.

ATTENTION:

When a bus expansion interface is missing in your rack the CPU will diagnose that all modules that rack are missing, even though they are physically connected in the rack.

RJ45 Connector LEDs

There are two LEDs placed in the RJ45 connectors, but only one is functional and helps the user in the installed physical network problem detection, indicating the existence of interface communication traffic. The LEDs meaning is presented in the table below.

Green	Meaning
Off	Network LINK is absent.
On	Active network LINK.
Blinking	Transmission or reception occurrence.

Web Page with Complete Status and Diagnostics List

Another way to access diagnostic information on Nexto Series is via web pages. Nexto Series CPU's has an embedded web pages server that provides all Nexto status and diagnostic information, which can be accessed using a browser.

More information about web page with complete status and diagnostic list can be found at Nexto Series CPUs User Manual – MU214605.

Diagnostics Mapped through Variables

All NX4000's diagnostics can be accessed through variables that can be handled by the user application or even forwarded to a supervisor using a communication channel. There are two different ways to access diagnostics in the user application: using symbolic variables with AT directive or direct representation variables. Altus recommends the use of symbolic variables. The table below shows all available diagnostics for NX4000 and their respective memory addresses, description, symbolic variable and string that will be shown on the CPU Graphical Display and Web.

Direct Representation Variable		Diagnostic Message	Symbolic Variable DG_modulename.	Description
Variable	Bit			
%QB(n)	0..7	Reserved		
%QB(n+1)	0	MODULE W/ DIAGNOSIS	tGeneral.bActiveDiagnostics	TRUE – Module has active diagnostics
		-		FALSE – Module doesn't have active diagnostic
	1	MODULE W/ FATAL ERROR	tGeneral.bFatalError	TRUE – Fatal error
		-		FALSE – No fatal error
	2	CONFIG. MISMATCH	tGeneral.bConfigMismatch	TRUE – Parameterization error
		-		FALSE – Parameterization success
	3	WATCHDOG ERROR	tGeneral.bWatchdogError	TRUE – Watchdog has been detected
		-		FALSE – No watchdog detected
	4	OTD SWITCH ERROR	tGeneral.bOTDSwitchError	TRUE – Failure on the diagnostic switch
		-		FALSE – No failure on the diagnostic switch
	5..7	Reserved		
	%QB(n+2)	0..7	Reserved	
%QB(n+3)	0	RACK ADDRESS CHANGED	tDetailed.bRackAddrChanged	TRUE – There was change in the address of the rack after module power-up
		-		FALSE – There was not change in the address of the rack after module power-up
	1	Reserved		
	2	BUS IN LINK DOWN	tDetailed.bLinkDownIn	TRUE – IN interface isn't properly connected
		-		FALSE – IN interface is connected
	3	BUS OUT LINK DOWN	tDetailed.bLinkDownOut	TRUE – OUT interface isn't properly connected
		-		FALSE – OUT interface is connected
	4	BUS IN INVALID LINK	tDetailed.bInvalidLinkIn	TRUE – IN interface with invalid connection
		-		FALSE – IN interface with valid connection
	5	BUS OUT INVALID LINK	tDetailed.bInvalidLinkOut	TRUE – OUT interface with invalid connection
		-		FALSE – OUT interface with valid connection
	6..7	Reserved		

Notes:

Direct Representation Variable: "n" is the address defined in the field %Q Start Address of Diagnostic Module on the NX4000's configuration screen – Modules Parameters tab in the MasterTool IEC XE.

Symbolic Variables: Some symbolic variables serve to access diagnostics. These diagnostics are stored in the direct representation variable, so the AT directive is used to map the symbolic variables in the direct representation variable. The

directive AT is a reserved word in the MasterTool IEC XE, that uses this directive to declare the diagnostics automatically on symbolic variables. All symbolic variables declared automatically can be found inside of the Diagnostics object.

Hot Swap

This product supports hot swap, by the way is important to view that the availability of the system will be depends of the configuration selected: with or without loopback or with expansion redundant, for further technical details, the System Configurations chapter should be consulted.

Manuals

For further technical details, configuration, installation and programming of Nexto Series the table below should be consulted.

The table below is only a guide of some relevant documents that can be useful during the use and maintenance of Nexto Series modules. The complete and updated table containing all documents of Nexto Series can be found at Nexto Series User Manual – MU214600.

Document Code	Description	Language
CT114000 CE114000 CS114000	Nexto Series – Technical Characteristics Série Nexto – Características Técnicas Serie Nexto – Especificaciones y Configuraciones	English Portuguese Spanish
MU214605 MU214100 MU214305	Nexto Series CPUs User Manual Manual de Utilização UCPs Série Nexto Manual del Usuario UCPs Serie Nexto	English Portuguese Spanish
MU214000 MU214600 MU214300	Nexto Series User Manual Manual de Utilização Série Nexto Manual del Usuario Serie Nexto	English Portuguese Spanish
MU299609 MU299048 MU299800	MasterTool IEC XE User Manual Manual de Utilização MasterTool IEC XE Manual del Usuario MasterTool IEC XE	English Portuguese Spanish