

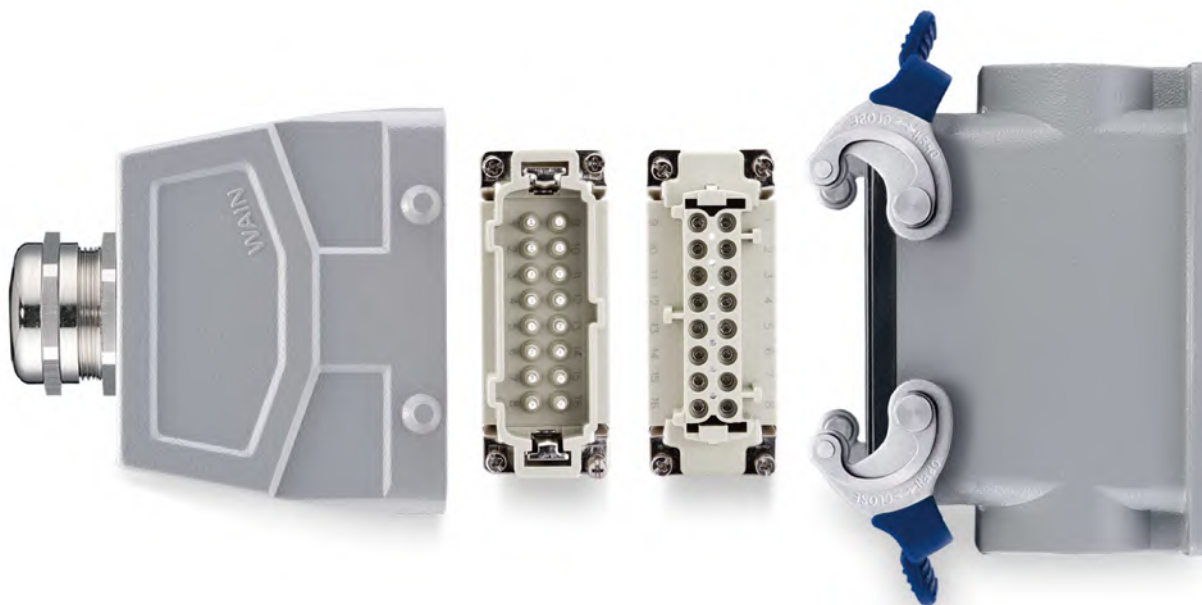

# HE SERIES

Standard products



## HE SERIES Standard inserts

## Technical characteristics

Specifications	DIN EN 60 664 DIN EN 61 984
Approvals	
Inserts	
Electrical data acc. to EN 61 984	
-Rated current	16A
-Rated voltage	500V
-Rated impulse voltage	6kV
-Pollution degree	3
-Pollution degree 2 also	16A 400/690V 6kV 2
Rated voltage acc. to UL	600V
Insulation resistance	$\geq 10^{10}\Omega$
Material	polycarbonate
Limiting temperatures	-40°C ...+125°C
Flammability acc. to UL 94	V0
Mechanical working life(mating cycles)	$\geq 500$
Contacts	
Material	copper alloy
Surface	hard-gold plated hard-silver plated
Contact resistance	$\leq 1m\Omega$
Screw terminal	
-Wire gauge	0.75-2.5mm <sup>2</sup>
-AWG	18-14
-Tightening/Test torque	0.5Nm
-Stripping length	7.0mm
Crimp terminal	
-Wire gauge	0.14-4.0mm <sup>2</sup>
-AWG	26-12
-Stripping length	7.5mm
Spring terminal	
-Wire gauge	0.14-2.5mm <sup>2</sup>
-AWG	26-14
-Stripping length	7-9mm
Spring terminal(Quick-in)	
-Wire gauge	0.5-2.5mm <sup>2</sup>
-AWG	20-14
-Stripping length	9-10mm
-Contact resistance	$\leq 3m\Omega$

## Current carrying capacity

The current carrying is limited by maximum temperature of materials for inserts and contacts including terminals

Control and test procedures according to DIN EN 60512-5

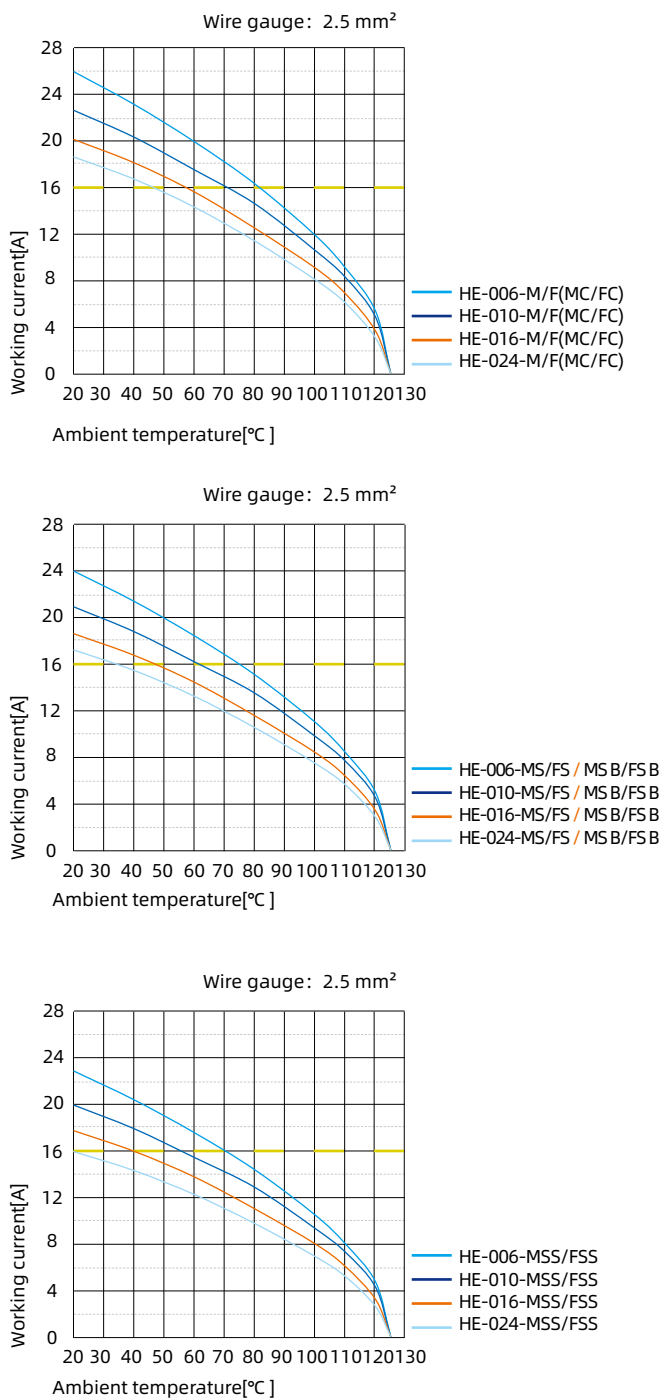

## HE-006 Standard inserts

500V 16A 6+ 

## Inserts

Remark: SPQ is 5pcs

Hoods/Housings: size 6B, please find the details on page 15-25~15-38.2.

## Screw terminal



Insert	Designation	Order No.
Male	HE-006-M	122 006 011 0001
Female	HE-006-F	122 006 021 0001

## Crimp terminal

Order crimp contacts separately



Insert	Designation	Order No.
Male	HE-006-MC <sup>1)</sup>	122 006 010 0001
Female	HE-006-FC <sup>1)</sup>	122 006 020 0001

1).can match PCB adapter,see page 14-04~14-05.

Male	HE-006-MC/N <sup>2)</sup>	122 006 010 0101
Female	HE-006-FC/N <sup>2)</sup>	122 006 020 0101

2).for crimp contacts 16A-Enhanced III ,see page 13-04.

Spring terminal, See P00-14 for the structural characteristics of spring.



Insert	Designation	Order No.
Male	HE-006-MS	122 006 012 0001
Female	HE-006-FS	122 006 022 0001

Male	HE-006-MS B	122 006 012 0101
Female	HE-006-FS B	122 006 022 0101

Double spring connection(Two terminal per contact)  
Only suitable for high structure shells

Male	HE-006-MSS	122 006 012 0201
Female	HE-006-FSS	122 006 022 0201

## Crimp contacts

## Crimp contacts 16A

Contact resistance ≤ 1mΩ  
silver plated

gold plated



More crimp contacts 16A see P13-04.

## Tools

## Crimping tool



## Contact removal tool



Remark: SPQ is 100pcs

Male	Order No.	Female	Order No.
CESM-0.37	101 019 110 0301	CESF-0.37	101 019 120 0301
CESM-0.50	101 019 110 0401	CESF-0.50	101 019 120 0401
CESM-0.75	101 019 110 0601	CESF-0.75	101 019 120 0601
CESM-1.0	101 019 110 0801	CESF-1.0	101 019 120 0801
CESM-1.5	101 019 110 0901	CESF-1.5	101 019 120 0901
CESM-2.5	101 019 110 1001	CESF-2.5	101 019 120 1001
CESM-3.0	101 019 110 1101	CESF-3.0	101 019 120 1101
CESM-4.0	101 019 110 1201	CESF-4.0	101 019 120 1201

CEGM-0.37	101 019 210 0301	CEGF-0.37	101 019 220 0301
CEGM-0.50	101 019 210 0401	CEGF-0.50	101 019 220 0401
CEGM-0.75	101 019 210 0601	CEGF-0.75	101 019 220 0601
CEGM-1.0	101 019 210 0801	CEGF-1.0	101 019 220 0801
CEGM-1.5	101 019 210 0901	CEGF-1.5	101 019 220 0901
CEGM-2.5	101 019 210 1001	CEGF-2.5	101 019 220 1001
CEGM-3.0	101 019 210 1101	CEGF-3.0	101 019 220 1101
CEGM-4.0	101 019 210 1201	CEGF-4.0	101 019 220 1201

Remark: SPQ is 1pc

Wire gauge	Designation	Order No.
0.14-4mm <sup>2</sup>	TL02G	198 001 001 0011

Wire gauge: 0.14-0.37mm<sup>2</sup> please select TL02 Crimping tool.

Application	Designation	Order No.
for crimp contacts 16A	TL01	198 001 000 0002

More tools detail please find the page 32-03~32-06.

1) Distance for contact max. 21 mm

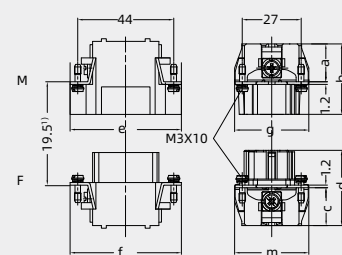

	a	b	e	g	c	d	f	m
M/F	16	32.4	51	34	16.8	34.5	50.5	34
MC/FC	18	33	51	34	18	35	50.5	34
MC/N / FC/N	18.3	34	51	34	19	36	51	34
MS/FS	18	33.3	51	34	18.2	35.4	50.5	34
MSS/FSS	34.5	49.5	50	34	33.4	50	50	34
MS B / FS B	19.5	34.7	51	34	19	36.5	51	34

Contact arrangement view from termination side

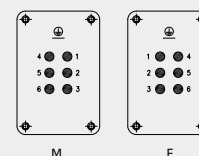

Panel cut out for inserts for use without hoods/housings

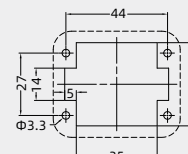

HE-006 Quick-in module

500V 16A 6+ 

Inserts

Remark: SPQ is 5pcs

Hoods/Housings: size 6B, please find the details on page 15-25-15-38.2.

Spring terminal(Quick-in)



Insert	Designation	Order No.
Male	HE-006-MQ P	122 000 099 0500
Female	HE-006-FQ P	122 000 099 0501

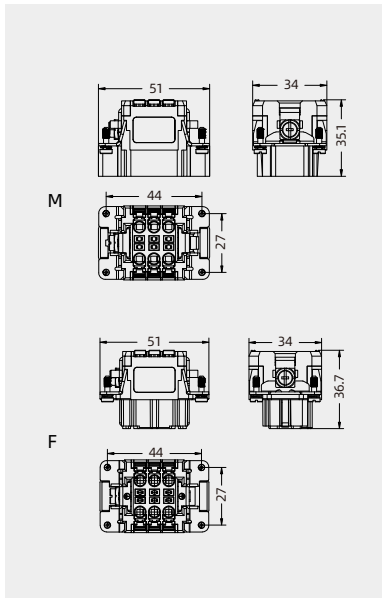

Bridging module

Remark: SPQ is 5pcs



Description	Designation	Order No.
	HEB/P-2T1	198 002 007 0029
	HEB/P-1T3	198 002 007 0028
	HEB/P-1T2	198 002 007 0027

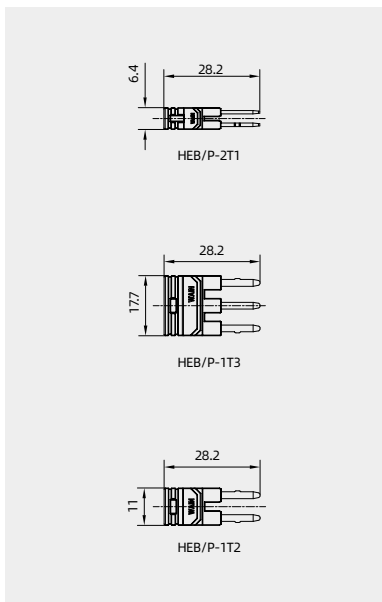

Bridging module



Remark: SPQ is 5pcs



Description	Designation	Order No.
	HEB/P-1T4	198 002 007 0033

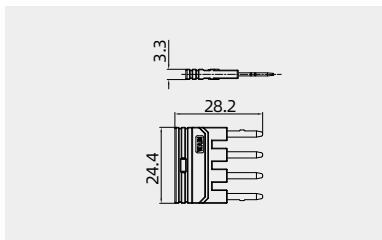

## HE-010 Standard inserts

500V 16A 10+ 

## Inserts

Remark: SPQ is 5pcs

Hoods/Housings: size 10B, please find the details on page 15-39~15-69.

## Screw terminal



Insert	Designation	Order No.
Male	HE-010-M	122 010 011 0001
Female	HE-010-F	122 010 021 0001

## Crimp terminal

Order crimp contacts separately



Insert	Designation	Order No.
Male	HE-010-MC <sup>1)</sup>	122 010 010 0001
Female	HE-010-FC <sup>1)</sup>	122 010 020 0001

<sup>1)</sup>can match PCB adapter, see page 14-04~14-05.

Spring terminal, See P00-14 for the structural characteristics of spring.



Insert	Designation	Order No.
Male	HE-010-MS	122 010 012 0001
Female	HE-010-FS	122 010 022 0001

Male	HE-010-MS B	122 010 012 0101
Female	HE-010-FS B	122 010 022 0101

Double spring connection (Two terminal per contact)  
Only suitable for high structure shells

Male	HE-010-MSS	122 010 012 0201
Female	HE-010-FSS	122 010 022 0201

1) Distance for contact max. 21 mm

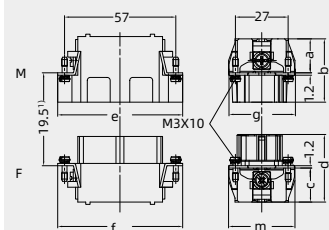

	a	b	e	g	c	d	f	m
M/F	16.5	32	64.5	34	16.8	34.2	64	34
MC/FC	18	33	64	34	17.5	35.2	64	34
MS/FS	18.5	33.5	64	34	18.5	35.6	64	34
MSS/FSS	34	49	64	34	33.5	49.5	63	34
MS B / FS B	19	34.5	64	34	18.6	36	64	34

Contact arrangement view from termination side

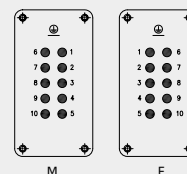

Panel cut out for inserts for use without hoods/housings

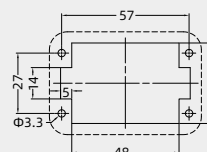

## Crimp contacts

## Crimp contacts 16A

Contact resistance ≤ 1mΩ  
silver plated

gold plated



More crimp contacts 16A see P13-04.

## Tools

## Crimping tool



## Contact removal tool



Male	Order No.	Female	Order No.
CESM-0.37	101 019 110 0301	CESF-0.37	101 019 120 0301
CESM-0.50	101 019 110 0401	CESF-0.50	101 019 120 0401
CESM-0.75	101 019 110 0601	CESF-0.75	101 019 120 0601
CESM-1.0	101 019 110 0801	CESF-1.0	101 019 120 0801
CESM-1.5	101 019 110 0901	CESF-1.5	101 019 120 0901
CESM-2.5	101 019 110 1001	CESF-2.5	101 019 120 1001
CESM-3.0	101 019 110 1101	CESF-3.0	101 019 120 1101
CESM-4.0	101 019 110 1201	CESF-4.0	101 019 120 1201

CEGM-0.37	101 019 210 0301	CEGF-0.37	101 019 220 0301
CEGM-0.50	101 019 210 0401	CEGF-0.50	101 019 220 0401
CEGM-0.75	101 019 210 0601	CEGF-0.75	101 019 220 0601
CEGM-1.0	101 019 210 0801	CEGF-1.0	101 019 220 0801
CEGM-1.5	101 019 210 0901	CEGF-1.5	101 019 220 0901
CEGM-2.5	101 019 210 1001	CEGF-2.5	101 019 220 1001
CEGM-3.0	101 019 210 1101	CEGF-3.0	101 019 220 1101
CEGM-4.0	101 019 210 1201	CEGF-4.0	101 019 220 1201

Remark: SPQ is 1pc

Wire gauge	Designation	Order No.
0.14-4mm <sup>2</sup>	TL02G	198 001 001 0011

Wire gauge: 0.14-0.37mm<sup>2</sup> please select TL02 Crimping tool.

Application	Designation	Order No.
for crimp contacts 16A	TL01	198 001 000 0002

More tools detail please find the page 32-03~32-06.

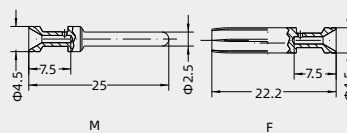

Identification	Wire gauge	Stripping length
no groove	0.14-0.37 mm <sup>2</sup>   AWG 26-22	7.5mm
no groove	0.5 mm <sup>2</sup>   AWG 20	7.5mm
1 groove	0.75 mm <sup>2</sup>   AWG 18	7.5mm
1 groove	1 mm <sup>2</sup>   AWG 18	7.5mm
2 grooves	1.5 mm <sup>2</sup>   AWG 16	7.5mm
3 grooves	2.5 mm <sup>2</sup>   AWG 14	7.5mm
wide groove	3 mm <sup>2</sup>   AWG 12	7.5mm
no groove	4 mm <sup>2</sup>   AWG 12	7.5mm

When the wire gauge is less than 0.75mm<sup>2</sup>, it's better to use the auxiliary pin assembly tool TL15.

Notes: The tools for crimp terminal may influence the product quality and stability. Please select the tools recognized by our company.

# HE-010 Quick-in module

500V 16A 10+ 

## Inserts

Remark: SPQ is 5pcs

Hoods/Housings: size 10B , please find the details on page 15-39~15-69.

### Spring terminal(Quick-in)



Insert	Designation	Order No.
Male	HE-010-MQ P	122 000 099 0502
Female	HE-010-FQ P	122 000 099 0503

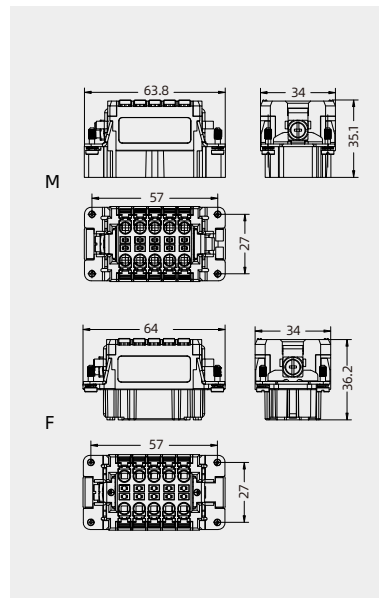

### Bridging module

Remark: SPQ is 5pcs



Description	Designation	Order No.
	HEB/P-2T1	198 002 007 0029
	HEB/P-1T3	198 002 007 0028
	HEB/P-1T2	198 002 007 0027

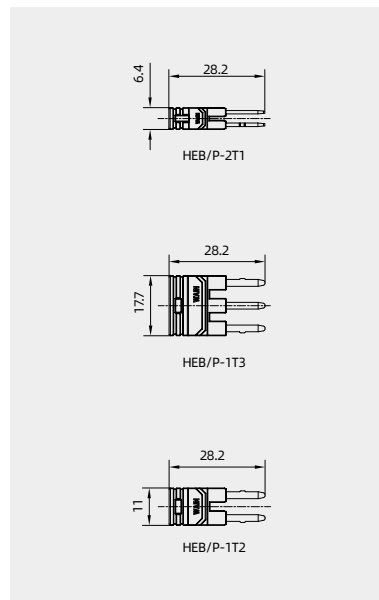

### Bridging module



Remark: SPQ is 5pcs



Description	Designation	Order No.
	HEB/P-1T4	198 002 007 0033

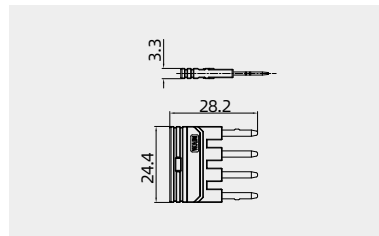



# HE-016 Quick-in module

500V 16A 16+ 

## Inserts

Remark: SPQ is 5pcs

Hoods/Housings: size 16B, please find the details on page 15-70~15-107.1.

### Spring terminal(Quick-in)

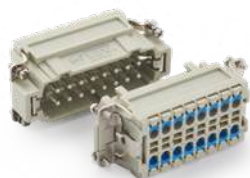

Insert	Designation	Order No.
Male	HE-016-MQ P	122 000 099 0504
Female	HE-016-FQ P	122 000 099 0505

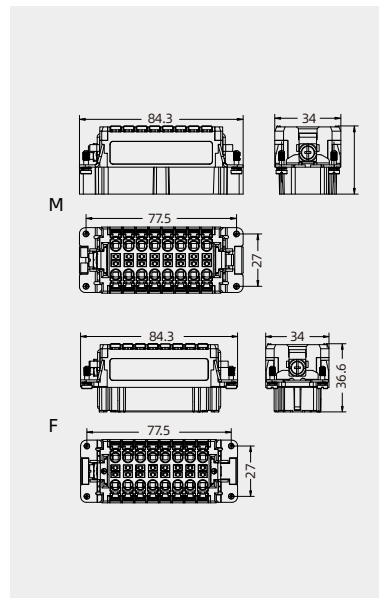

### Bridging module

Remark: SPQ is 5pcs



Description	Designation	Order No.
	HEB/P-2T1	198 002 007 0029

	HEB/P-1T3	198 002 007 0028
--	-----------	------------------

	HEB/P-1T2	198 002 007 0027
--	-----------	------------------

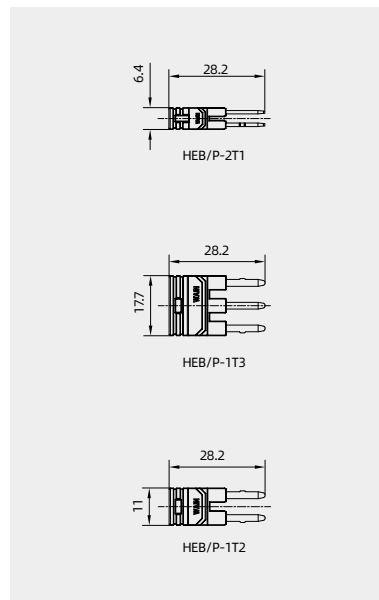

### Bridging module



Remark: SPQ is 5pcs



Description	Designation	Order No.
	HEB/P-1T4	198 002 007 0033

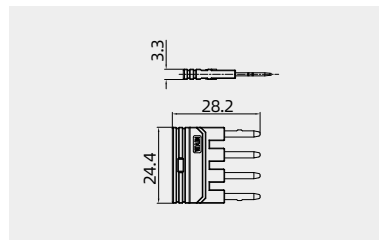



# HE-024 Quick-in module

500V 16A 24+ 

## Inserts

Remark: SPQ is 5pcs

Hoods/Housings: size 24B, please find the details on page 15-108~15-150.

### Spring terminal(Quick-in)



Insert	Designation	Order No.
Male	HE-024-MQ P	122 024 010 0003
Female	HE-024-FQ P	122 024 020 0003

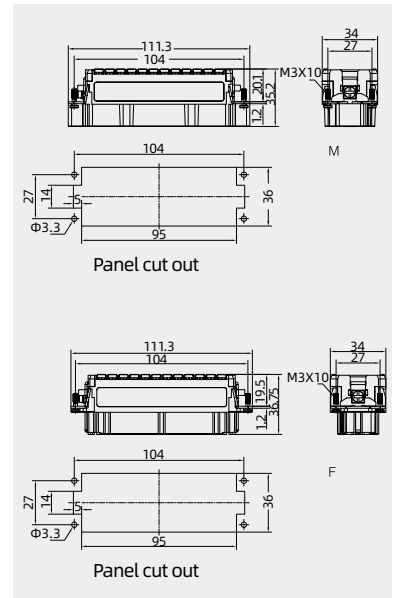

### Bridging module

Remark: SPQ is 5pcs



Description	Designation	Order No.
	HEB/P-2T1	198 002 007 0029
	HEB/P-1T3	198 002 007 0028
	HEB/P-1T2	198 002 007 0027

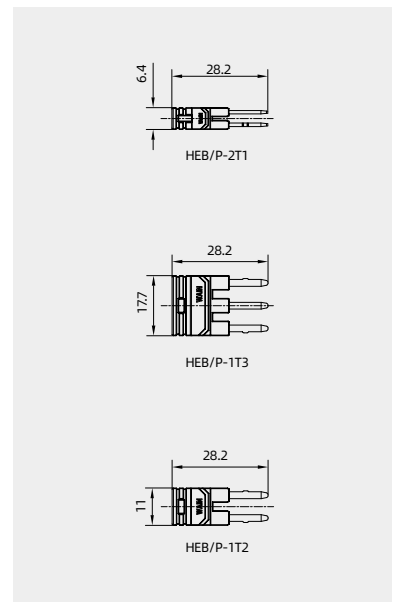

### Bridging module



Remark: SPQ is 5pcs



Description	Designation	Order No.
	HEB/P-1T4	198 002 007 0033

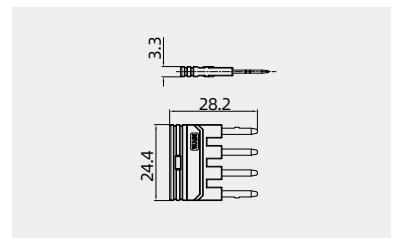



# HE-048 Standard inserts

500V 16A 48+



## Inserts

Remark: SPQ is 5pcs

Hoods/Housings: size 48B, please find the details on page 15-160~15-162.

### Screw terminal



Insert	Designation	Order No.
Male	HE-024-M	122 024 011 0001
	HE-024-M(25-48)	122 024 011 0002
Female	HE-024-F	122 024 021 0001
	HE-024-F(25-48)	122 024 021 0002

### Crimp terminal

Order crimp contacts separately



Insert	Designation	Order No.
Male	HE-024-MC	122 024 010 0001
	HE-024-MC(25-48) <sup>1)</sup>	122 024 010 0002
Female	HE-024-FC	122 024 020 0001
	HE-024-FC(25-48) <sup>1)</sup>	122 024 020 0002

<sup>1)</sup>can match PCB adapter,see page 14-04-14-05.

### Spring terminal, See P00-14 for the structural characteristics of spring.



Insert	Designation	Order No.
Male	HE-024-MS	122 024 012 0001
	HE-024-MS(25-48)	122 024 012 0002
Female	HE-024-FS	122 024 022 0001
	HE-024-FS(25-48)	122 024 022 0002
Male	HE-024-MS B	122 024 012 0101
	HE-024-MS B(25-48)	122 024 012 0102
Female	HE-024-FS B	122 024 022 0101
	HE-024-FS B(25-48)	122 024 022 0102
Double spring connection(Two terminal per contact) Only suitable for high structure shells		
Male	HE-024-MSS	122 024 012 0201
	HE-024-MSS(25-48)	122 024 012 0202
Female	HE-024-FSS	122 024 022 0201
	HE-024-FSS(25-48)	122 024 022 0202

1) Distance for contact max. 21 mm

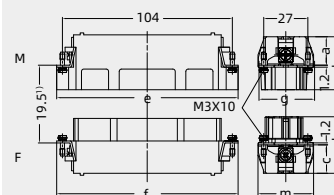

M/F	a	b	e	g	c	d	f	m
MC/FC	18.3	33.5	111	34	18.3	35.5	111	34
MS/FS	18.5	33.6	111	34	18.5	35.6	111	34
MSS/FSS	34	49	110	34	32	49	110	34
MS B / FS B	19.6	34.7	111	34	19	36.2	111	34

Contact arrangement view from termination side

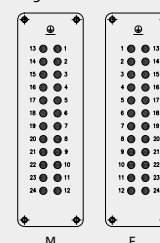

Panel cut out for inserts for use without hoods/housings

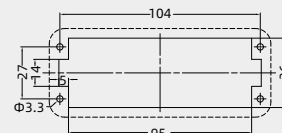

## Crimp contacts

Remark: SPQ is 100pcs

### Crimp contacts 16A

Contact resistance ≤ 1mΩ  
silver plated



gold plated



Male	Order No.	Female	Order No.
CESM-0.37	101 019 110 0301	CESF-0.37	101 019 120 0301
CESM-0.50	101 019 110 0401	CESF-0.50	101 019 120 0401
CESM-0.75	101 019 110 0601	CESF-0.75	101 019 120 0601
CESM-1.0	101 019 110 0801	CESF-1.0	101 019 120 0801
CESM-1.5	101 019 110 0901	CESF-1.5	101 019 120 0901
CESM-2.5	101 019 110 1001	CESF-2.5	101 019 120 1001
CESM-3.0	101 019 110 1101	CESF-3.0	101 019 120 1101
CESM-4.0	101 019 110 1201	CESF-4.0	101 019 120 1201
CEGM-0.37	101 019 210 0301	CEGF-0.37	101 019 220 0301
CEGM-0.50	101 019 210 0401	CEGF-0.50	101 019 220 0401
CEGM-0.75	101 019 210 0601	CEGF-0.75	101 019 220 0601
CEGM-1.0	101 019 210 0801	CEGF-1.0	101 019 220 0801
CEGM-1.5	101 019 210 0901	CEGF-1.5	101 019 220 0901
CEGM-2.5	101 019 210 1001	CEGF-2.5	101 019 220 1001
CEGM-3.0	101 019 210 1101	CEGF-3.0	101 019 220 1101
CEGM-4.0	101 019 210 1201	CEGF-4.0	101 019 220 1201

More crimp contacts 16A see P13-04.

### Tools

Crimping tool



Contact removal tool



Remark: SPQ is 1pc

Wire gauge	Designation	Order No.
0.14-4mm <sup>2</sup>	TL02G	198 001 001 0011
Wire gauge: 0.14-0.37mm <sup>2</sup> please select TL02 Crimping tool.		
Application	Designation	Order No.
for crimp contacts 16A	TL01	198 001 000 0002

More tools detail please find the page 32-03-32-06.

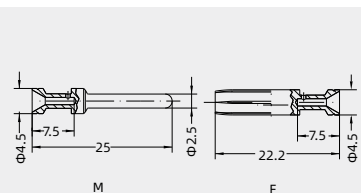

Identification	Wire gauge	Stripping length
no groove	0.14-0.37 mm <sup>2</sup>   AWG 26-22	7.5mm
no groove	0.5 mm <sup>2</sup>   AWG 20	7.5mm
1 groove	0.75 mm <sup>2</sup>   AWG 18	7.5mm
1 groove	1 mm <sup>2</sup>   AWG 18	7.5mm
2 grooves	1.5 mm <sup>2</sup>   AWG 16	7.5mm
3 grooves	2.5 mm <sup>2</sup>   AWG 14	7.5mm
wide groove	3 mm <sup>2</sup>   AWG 12	7.5mm
no groove	4 mm <sup>2</sup>   AWG 12	7.5mm

When the wire gauge is less than 0.75mm<sup>2</sup>, it's better to use the auxiliary pin assembly tool TL15.

Notes: The tools for crimp terminal may influence the product quality and stability. Please select the tools recognized by our company.

## HE Shrapnel push tool

## Tools

HE B Spring open machine<sup>1)</sup>

Remark: SPQ is 1pc



Description	Designation	Order NO.
for all HE B spring inserts	SOM01	198 001 003 0008

1) It can open all the shrapnel windows of insert at one time; suitable for using in mass assembly, greatly improving the efficiency of the connection.

